



The Mid-Atlantic

Nutrient Management Handbook

Land Grant Universities in **Delaware, Maryland, Pennsylvania, Virginia** and **West Virginia**, and **USDA's Cooperative State Research, Education and Extension Service (CSREES)**, working with **EPA Region III**, have formed a partnership to advance water quality protection and restoration efforts in the Mid-Atlantic by providing water quality science support, training and education. This regional program is anchored by, and complements, state water quality programs and existing Extension efforts.



This material is based upon work supported by the Cooperative State Research, Education, and Extension Service, U.S. Department of Agriculture, under Agreement No. 2002-51130-01522.

Any opinions, findings, conclusions, or recommendations expressed in this publication are those of the author(s) and do not necessarily reflect the view of the U.S. Department of Agriculture.

The Mid-Atlantic Nutrient Management Handbook

Foreword

Purpose of this handbook

Delaware, Pennsylvania, Maryland, Virginia, and West Virginia, and Virginia, the five states in the Mid-Atlantic region, all require Certified Nutrient Management Plans to be completed for certain agricultural programs. The Mid-Atlantic Regional Nutrient Management Handbook is a revision and update of the former nutrient management training manual for the Chesapeake Bay watershed (Nagle et al., 2000), which was written by extension specialists and researchers from Virginia, Pennsylvania, and Maryland for use by state regulatory agencies as a reference text for their certified nutrient management training programs. This revised handbook was developed to incorporate the advances in the understanding of managing soils, crops, and nutrients for the protection of surface and ground water that have occurred since the original manual was published, and to broaden the scope of the manual to cover the entire Mid-Atlantic region.

Portions of this revised handbook were modified from the Chesapeake Bay Region Nutrient Management Training Manual (Nagle et al., 2000). That publication contained sections that were adapted in whole or in part with permission from IMC Fertilizer (1992), PPI, (1993), and Virginia Department of Conservation and Recreation (1993).

References cited

IMC Fertilizer. 1992. Efficient fertilizer use. 3rd edition. DBFT2-001C. IMC Fertilizer, Inc., Mundelein, IL.

Nagle, S., G. Evanylo, W.L. Daniels, D. Beegle, and V. Groover. 2000. Chesapeake Bay Region Nutrient Management Training Manual. F. Coale (ed.). Virginia Cooperative Extension Publication 700-054.

PPI. 1993. Soil fertility manual. Item # 50-5100. Phosphorus and Potash Institute, Norcross, GA.

Virginia Department of Conservation and Recreation. 1993. Nutrient management handbook. 2nd edition. VA DCR, Richmond, VA.

Contributors

Editors Kathryn C. Haering and Gregory K. Evanylo, Department of Crop and Soil Environmental Sciences, Virginia Tech

Authors A.O. Abaye, Department of Crop and Soil Environmental Sciences, Virginia Tech
Thomas J. Basden, Center for Agricultural and Natural Resources Development, West Virginia University
Douglas Beegle, Department of Crop and Soil Sciences, Penn State University
Gregory D. Binford, Department of Plant and Soil Sciences, University of Delaware
W. Lee Daniels, Department of Crop and Soil Environmental Sciences, Virginia Tech
Sjoerd Willem Duiker, Department of Crop and Soil Sciences, Penn State University
Gregory K. Evanylo, Department of Crop and Soil Environmental Sciences, Virginia Tech
Kathryn C. Haering, Department of Crop and Soil Environmental Sciences, Virginia Tech
David J. Hansen, Department of Plant and Soil Sciences, University of Delaware
Greg Mullins, Department of Crop and Soil Environmental Sciences, Virginia Tech
Richard W. Taylor, Department of Plant and Soil Sciences, University of Delaware

Acknowledgements

This project was funded by the Cooperative State, Research, Education, and Extension Service of the U.S. Department of Agriculture, through the Mid-Atlantic Regional Water Program at the University of Maryland in College Park. The editors also thank:

Jim Baker, Department of Crop and Soil Environmental Sciences, Virginia Tech; David Kindig and Russ Perkinson, Virginia Department of Conservation and Recreation; and Ann M. Wolf, Penn State Agricultural Analytical Services Laboratory, for reviewing manual chapters.

Sue Brown, Department of Crop and Soil Environmental Sciences, Virginia Tech, and Jennifer Salak, Department of Natural Resource Sciences and Landscape Architecture, University of Maryland, for proofreading and editorial assistance.

Frank Coale and Trish Steinhilber, Department of Natural Resource Sciences and Landscape Architecture, University of Maryland, for assistance in planning the manual.

Don Armstrong of the Phosphorus and Potash Institute, and Doug Beegle, Department of Crop and Soil Sciences, Penn State University, for help with figures.

Tom Simpson, Jake Vandevort, and Jenn Aiosa of the Mid-Atlantic Regional Water Program, and Amanda Porterfield of AHNR-IT, Virginia Tech, for technical support.

Table of Contents

Chapter 1. Introduction to Nutrient Management	1
<i>Gregory K. Evanylo and Douglas Beegle</i>	
The impact of agriculture on water quality	2
Fate and transport of nutrients	4
Nutrient cycles and management on different types of farms	7
Nutrient management planning	11
References cited	21
Chapter 2. Regional Landscapes and the Hydrologic Cycle	22
<i>W. Lee Daniels</i>	
Introduction	23
Soils and landscapes of the Mid-Atlantic region	23
The hydrologic cycle and soil-water balances	27
References cited	30
Chapter 3. Concepts of Basic Soil Science	31
<i>W. Lee Daniels and Kathryn C. Haering</i>	
Soil formation and soil horizons	33
Soil physical properties	37
Soil organic matter	43
Soil-water relationships	44
Soil chemical properties	46
Soil survey	50
References cited	52
References for additional information	52
Chapter 4. Basic Soil Fertility	53
<i>Greg Mullins and David J. Hansen</i>	
Plant nutrition	55
Nutrient deficiency symptoms	59
Nutrient uptake by crops	63
Soil properties that influence nutrient availability	65
Liming	68
Nitrogen	71
Phosphorus	78
Potassium	82
Secondary plant nutrients	85
Micronutrients	87
References cited	93
Chapter 5. Crop Production	94
<i>Thomas J. Basden, A.O. Abaye, and Richard W. Taylor</i>	
Introduction	96

Agronomic crops.....	96
Nitrogen uptake and fertilization for corn and small grains	106
Forage, hay, and cover crops	109
Links to information on turfgrass, fruit, and vegetable production	125
References cited.....	126
References for additional information	126
Chapter 6. Soil Management	127
<i>Sjoerd Willem Duiker</i>	
Introduction.....	128
Soil quality	128
Soil erosion	129
Controlling soil erosion.....	134
Soil compaction	136
Controlling compaction	140
Residue management and conservation tillage.....	144
References cited.....	150
Chapter 7. Nutrient Testing, Analysis, and Assessment.....	151
<i>Douglas Beegle</i>	
Soil testing	153
Soil sampling	153
Soil laboratory analysis.....	161
Soil test interpretation.....	164
Soil test recommendations	168
Assessing soil acidity.....	171
Assessing soil N levels.....	172
Assessing soil P levels for environmental management.....	177
Plant analysis	180
Sampling plant tissue for elemental analysis.....	181
Interpreting plant analysis data	183
References cited.....	186
Chapter 8. Commercial Fertilizers.....	187
<i>Gregory D. Binford</i>	
Introduction.....	189
Nitrogen fertilizers.....	189
Phosphorus fertilizers.....	192
Potassium fertilizers.....	193
Sulfur, calcium, and magnesium fertilizers	194
Micronutrient fertilizers	195
Applying fertilizers	197
Liming materials	202
References for additional information	206

Chapter 9. Manure as a Nutrient Source	207
<i>David J. Hansen</i>	
Introduction.....	208
Manure production and composition	208
Manure storage and handling.....	213
Land application of manure	216
References cited.....	224
Chapter 10. Land Application of Biosolids	226
<i>Gregory K. Evanylo</i>	
Introduction.....	228
Production and characteristics of biosolids.....	229
Federal regulations.....	233
Managing biosolids for agricultural use	238
Calculating nutrient-based biosolids application rates	244
Land application methods.....	247
References cited.....	251

Chapter 1. Introduction to Nutrient Management

Gregory K. Evanylo

Department of Crop and Soil Environmental Sciences, Virginia Tech

Douglas Beegle

Department of Crop and Soil Sciences, Penn State University

Table of Contents

The impact of agriculture on water quality.....	2
Agricultural sources of water pollution in the Mid-Atlantic region	2
Effect of agricultural non-point source pollution on water quality.....	3
Fate and transport of nutrients	4
Nitrogen	4
Phosphorus.....	5
Nutrient loss from organic wastes.....	6
Nutrient cycles and management on different types of farms	7
Introduction: why nutrient losses are a problem.....	7
Cash crop farm.....	8
Crop and livestock farm.....	9
Intensive animal production farm	10
Nutrient management planning.....	11
Purpose of nutrient management	11
The nutrient management process	11
Nutrient management assessment I: nutrient status and balance	12
Nutrient management assessment II: sites which may have accelerated nutrient loss .	13
Selecting management options	16
Nutrient management planning.....	17
Implementation	19
Keeping records	19
References cited.....	21

The impact of agriculture on water quality

Agricultural sources of water pollution in the Mid-Atlantic region

Despite the enormous progress that has been achieved in reducing water pollution, almost 40% of U.S. waters that have been assessed have not met water quality standards (Zygmunt, 2000). According to state water quality agency data submitted to the United States Environmental Protection Agency (U.S. EPA), about 15,000 water bodies are impaired from siltation, nutrients, bacteria and other pathogens, oxygen-depleting constituents, trace elements, pesticides, and other organic chemicals. Many of these pollutants do not come from a single point such as a sewage outfall or an industrial discharge pipe and are thus termed *non-point source* pollution.

Nutrients, particularly nitrogen (N) and phosphorus (P), are the major pollutants in lakes and estuaries and the second leading source of pollution in rivers (U.S. EPA, 1998). Life within rivers, streams, lakes, and bays could not exist without nutrients; however, an excess of nutrients (*eutrophication*) may cause ecological problems and can harm aquatic life.

Smith and Alexander (2000) estimated that nearly all of the N and P exported from watersheds in the Mid-Atlantic are from non-point sources, to which fertilizer and animal manures used in agriculture contribute significantly (Table 1.1). A six-year study by the U.S. EPA (1983) revealed that runoff from farmland was a major source of pollution contributing to water quality decline in the Chesapeake Bay. While these nutrient loading estimates continue to be the source of debate and further research, agricultural non-point source pollution must clearly be reduced in order to reverse the degradation that the Bay and other Mid-Atlantic regional waters have undergone.

Table 1.1. Point and non-point source contributions to total nitrogen and phosphorus export from Mid-Atlantic watersheds.

Nutrient	Total export ^a kg/ha/yr	Point source	Non-point source			
			Fertilizer	Animal agriculture	Atmosphere	Non-agricultural runoff
			-----Median, as % of total export-----			
Nitrogen	9.0	4	14	16	32	22
Phosphorus	0.68	14	19	25	NA	22

^a Total export is the median export from hydrologic cataloging.

Effect of agricultural non-point source pollution on water quality

Excess N and P can cause excessive growth of algae, a type of phytoplankton, whose eventual death and decomposition reduces the dissolved oxygen (DO) concentration in the water. Low DO reduces respiration, growth, and reproduction of aquatic organisms and can result in the death of fish and other aquatic organisms.

Another adverse effect associated with excessive nutrient concentrations in the Chesapeake Bay and some tributaries was the appearance of the toxic microorganism *Pfiesteria* in 1997, which caused both death of fish and adverse health effects in commercial and recreational fishermen. Foul tastes and odors often occur in drinking water populated by excessive algal blooms in surface water.

Excessive phytoplankton growth also reduces water clarity, which reduces light transmission available for the growth of submerged aquatic vegetation (SAV). Submerged aquatic vegetation serves as an important habitat for fish, crabs, and other species of economic and environmental importance. Due in large part to increased nutrient concentrations in the Bay, areas of SAV beds have been greatly reduced in recent years because of the shading effect of the phytoplankton growth. Vast areas of SAV were well documented from colonial times until the 1960s, during which time the Bay was one of the most productive estuaries in the world.

Phosphorus is generally the limiting nutrient for phytoplankton growth in the saltwater portions of the Bay during all seasons except summer. During the summer, however, N is the limiting nutrient. Since most phytoplankton growth in the Bay occurs during the summer months, N control strategies become very important.

Agricultural impacts such as sedimentation, eutrophication, and general water quality degradation due to presence of inorganic or organic constituents and pathogens in the water and sediments also occur in tributaries miles from the Bay. Phosphorus is usually the limiting nutrient in these upper tributaries of the Bay watershed and in other freshwater bodies. Other agricultural impacts may include contamination of groundwater, which is a source of drinking water for many rural communities, resulting from migration of pesticides, nitrates, and pathogens.

Eutrophication standards vary among major types of water bodies such as rivers, lakes, reservoirs, estuaries, and coastal systems. For example, critical concentrations of dissolved P recommended or established for lakes (0.01-0.05 mg/L) and streams (0.10 mg/L) can differ by an order of magnitude (Sharpley et al., 1996). Critical concentrations have been suggested for total N (2.2 mg/L) and P (0.15 mg/L) in rivers, but these values are well above the average total dissolved nutrient concentrations expected for unpolluted major

rivers (~0.375 mg N/L and ~0.025 mg P/L), respectively (Meybeck, 1982). The nitrate N groundwater standard of 10 mg/L established to protect human health has been demonstrated to be too low; however, such a concentration may be too high as an ecological standard (L'Hirondel, 2005).

Fate and transport of nutrients

Nitrogen

Nitrogen, an essential element for plant growth and animal nutrition, is the nutrient taken up in the largest amount by crops. Nitrate (NO_3^-) is the major inorganic form of N in most soils. This anion is not attracted by the predominately negatively charged soil colloids and is, therefore, quite mobile and moves freely with soil water. Nitrogen application to soils beyond that required for plant uptake and maintenance of the soil microbial biomass will generally result in NO_3^- leaching and possible high NO_3^- levels in groundwater. Elevated concentrations of NO_3^- in drinking water may lead to methemoglobinemia in infants, the formation of carcinogenic nitrosamines in the human stomach, and hypertension. A national survey of drinking water wells (U.S. EPA, 1990) found that NO_3^- was the most common contaminant, with 52% of the 94,600 community water systems tested containing detectable concentrations and 1.2% of those water sources exceeding the drinking water standard of 10 mg $\text{NO}_3\text{-N}$ per liter (10 ppm). Localized contamination has been measured beneath cropped, well-drained soils that received excessive applications of manure and commercial fertilizer in the Mid-Atlantic states and the Delmarva Peninsula (Spalding and Exner, 1993).

While leaching losses are generally considered the major environmental threat from N, runoff losses are also possible. The potential of each system to contribute N to surface waters will depend upon its transport (i.e., erosion and runoff) capability and the surface soil N concentration (Figure 1.1A). Nitrogen is lost to surface water as NO_3^- from recently applied inorganic fertilizers or in particulate organically-bound forms. Movement of excessive amounts of N to surface waters can result in a number of undesirable effects, such as eutrophication, associated algal blooms, and subsequent oxygen depletion.

Managing N to minimize NO_3^- losses is very difficult because of the many possible loss pathways. For example, increased water infiltration may increase leaching of nitrate if practices to reduce runoff and erosion, such as no-till, are adopted (see Figure 1.1B). Similarly, incorporating manure to reduce N volatilization losses increases the risk of N loss through runoff, erosion, and leaching. Consequently, one of the primary emphases of nutrient management is minimizing the potential source of N in the system because any excess N will likely be lost to the environment in some manner.

Figure 1.1. (A) General fate of N and (B) how adopting processes to reduce erosion and runoff increases N leaching losses.

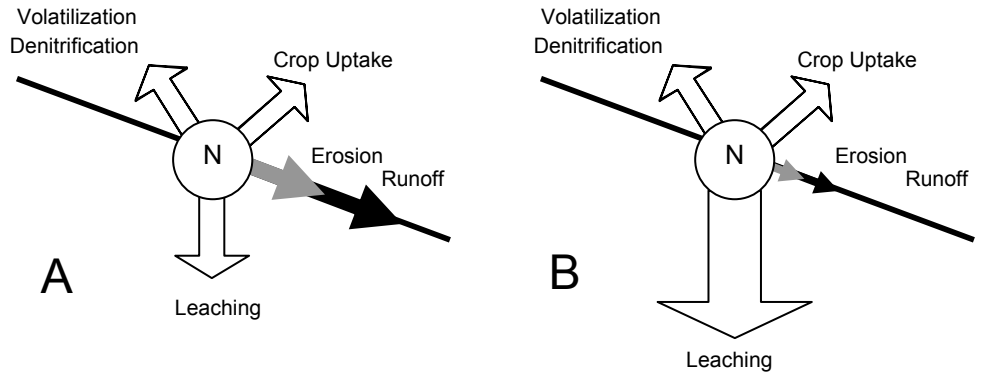

Phosphorus

Phosphorus is another element required by plants and animals whose accumulation in water bodies may result in nutrient pollution. Increased public and regulatory concern over the use and application of P to agricultural lands is due to the eutrophication that can result from increased P loadings to surface waters (Daniel et al., 1998). Algal and aquatic weed growth in most inland surface water systems is P-limited, and elevated P levels result in algal blooms, oxygen depletion, and occasional problems with drinking water taste and odor.

Phosphorus is typically immobile in soil and seldom migrates downward with soil water to any great extent because it is strongly adsorbed by and/or precipitated as highly insoluble soil mineral phases (Figure 1.2A). Much of the P that is applied to soils in fertilizer, manure, and biosolids is retained in the near-surface layer in various inorganic precipitates and in adsorbed forms that prevent it from leaching.

The risk of groundwater contamination by P in crop production systems is usually not high, although leaching can be a significant loss pathway for P in coarse-textured (sandy) soils with shallow water tables. Runoff and erosion losses to surface waters are the major water quality risks from P (Figure 1.2B).

Figure 1.2. (A) General fate of P and (B) how adopting processes to reduce erosion and runoff does not usually increase P leaching losses.

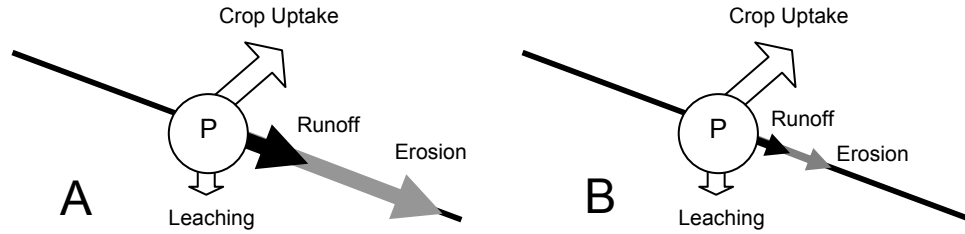

Because P is strongly adsorbed by soil solids, P runoff from permanently vegetated areas such as perennial sods or forests is minimal, and largely occurs as traces of orthophosphate (PO_4^{3-}) ions in solution. In areas where erosion risk increases, such as where annual crops are grown using conventional tillage, the total P loss increases greatly as the P is moved in solid particulate form with the eroding soil. Although water-soluble P is immediately available for biological uptake, sediment-bound or particulate P forms (or *bioavailable particulate P*) are released over longer periods. The overall impact of a given production system on P runoff to local surface waters will, therefore, be primarily dependent upon relative rates of sediment loss and the P levels in these eroding soil surfaces.

Nutrient loss from organic wastes

Many crop production systems in the Chesapeake Bay region receive various organic wastes as fertilizer amendments. Organic amendments such as manure, municipal wastewater sewage sludge (biosolids), municipal solid waste compost, and other miscellaneous agricultural, municipal, and industrial by-products all have the potential to improve soil properties while increasing organic matter levels. Organic amendments are particularly effective at improving the productivity of marginal or degraded lands.

The major water quality concerns associated with the land application of organic by-products are the direct runoff or erosion of the organic material and any mobile constituents (such as N, P, or pathogens) into surface waters and the migration of NO_3^- and pathogens to groundwater. Application rates for these materials are generally based on the estimated amount of plant available N in the by-product, but P can be the limiting nutrient for application to soils whose P adsorption capacity is becoming saturated. Phosphorus runoff may occur in soils that have routinely received heavy annual applications of animal manure because the maximum P retention capability of such soils is being approached or exceeded.

Nutrient cycles and management on different types of farms

**Introduction:
why nutrient
losses are a
problem**

A common misconception is that farmers, in general, are mismanaging nutrients on their farms. While there is usually room for improved management, the nutrient pollution problems from agriculture primarily result from the way modern agriculture has evolved.

Prior to World War II, most farms included both animals and crops. Nutrient use on those farms was interdependent because manure nutrients were used to produce crops which were fed to animals that generated manure. Fertilizer nutrients became more economical after the war, which resulted in the separation of crop and animal agriculture. With the loss of the on-farm relationship between feed crops and animals came a significant increase in animal agriculture in some areas that was supported by concentrated crop agriculture in other areas, often far away. Currently, nutrients from imported feed often accumulate to very high levels on the farms where the animals are located because of manure applications on those farms (Figure 1.3).

While farmers collectively have been making sound economic management decisions, the unexpected consequence of these decisions has resulted in the increased potential for nutrient pollution in the areas where nutrients are accumulating. Significant long term strategic changes in the structure of animal agriculture, rather than simple management changes, will be required to develop solutions to the problems inherent in this system. The following sections describe nutrient cycles and management on different farm types. Understanding these cycles can increase the adoption of strategies to enhance nutrient use efficiency and reduce potential environmental impacts.

Figure 1.3. Nutrient flows in modern animal agriculture.

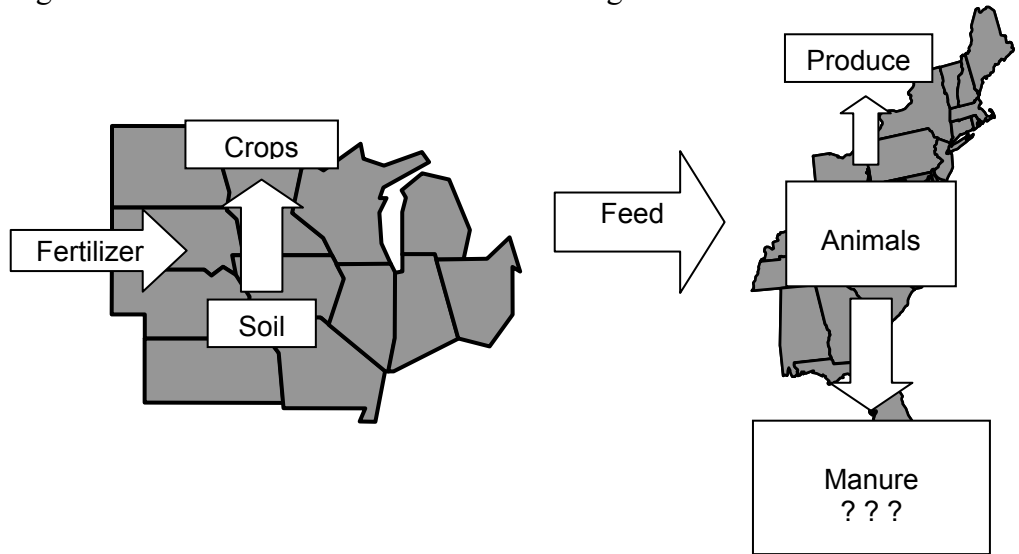

Cash crop farm Nutrients come to a modern cash crop farm in fertilizers and other materials applied directly to the fields (Figure 1.4). Crops harvested from the fields remove a fraction of the applied nutrients, which leave the farm when the crops are sold. On a cash crop farm, there is a direct connection between the flow of nutrients and the agronomic or economic performance of the farm.

Traditional economic and agronomic incentives can be effective in guiding nutrient use on cash crop farms to optimize both crop production and environmental protection. Improper management can result in significant nutrient losses other than those removed in crops and negative economic consequences for the farmer. The cost of practices that reduce nutrient losses on a cash crop farm can at least be partially offset by decreased costs in purchased fertilizer. The nutrient balance on a well-managed farm is usually very close to zero (Table 1.2).

Figure 1.4. Nutrient cycles on cash crop farms.

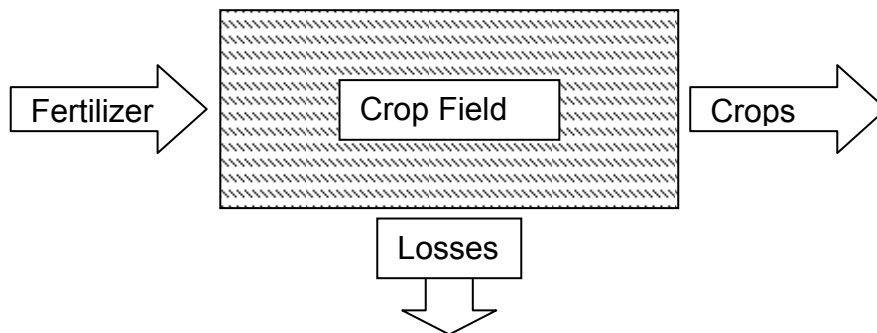

Table 1.2. Example of nutrient balance (P_2O_5) on a cash-crop farm in Pennsylvania.

Input:	lb P_2O_5/A/yr
Fertilizer	36
Output:	
Crop removal	32
Balance	+4

Crop and livestock farm

On farms with livestock (e.g., a dairy), a large proportion of the plant nutrients from crops produced as feed for the animals are traditionally returned to the farm fields in manure (Figure 1.5). This pattern of nutrient use and cycling varies significantly from a modern cash crop farm. The plant nutrients in the feed inputs can offset the nutrients removed from the farm as sold animal products.

Figure 1.5. Nutrient cycles on a modern crop and livestock farm.

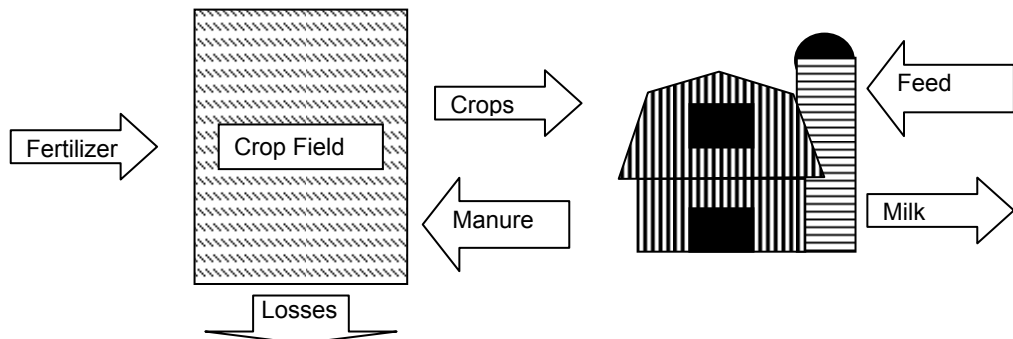

Off-farm feed inputs enable crop and livestock farms to have more animals on fewer acres. Thus, on modern crop-livestock farms, the manure produced by the animals is often not spread on the fields where the crops were produced. Off-farm feed nutrients can exceed what is needed for the crops and result in excess manure nutrients that can be potential sources of water contamination. Accounting for all sources of plant nutrients being applied to fields is an important management practice for protecting the environment from negative impacts caused by the over-application of nutrients to crop fields.

Neither crop production nor fertilizer use is directly connected to the output of such farms because farms with this structure primarily sell animal products. Farm performance depends more on the animal husbandry skills of the farmer than successful crop production. The economic viability of the farm is not as sensitive to the decisions about plant nutrient use in the fields

as it is on the cash crop farm. The dairy farm given as an example in Table 1.3 demonstrates the nutrient excess that can occur as imported feed becomes significant.

Table 1.3. Example of nutrient balance on a dairy farm in Pennsylvania.

Inputs:	lb P₂O₅/A/yr
Fertilizer	22
Feed	60
Output:	
Milk	24
Balance	+58

Intensive animal production farm

Trends in animal housing and the success of crop production on cash crop farms in specialized geographic regions have made it possible to concentrate large numbers of animals, such as poultry and swine, on small land areas. Most, if not all, of the feed necessary for these animals can be economically transported to the farm where the animals are housed (Figure 1.6).

Figure 1.6. Intensive animal production farm with limited crop production.

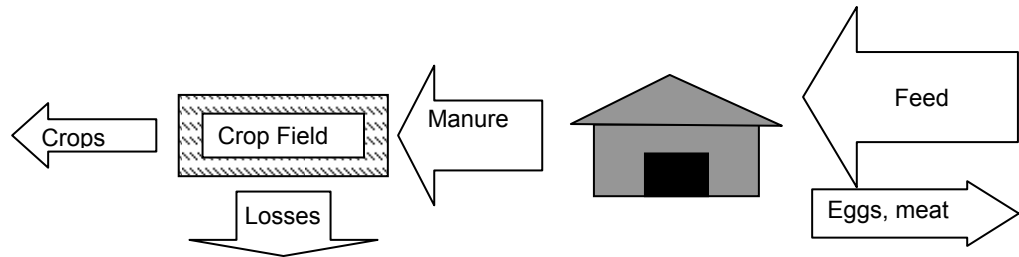

Although intensive poultry and swine farms may produce crops for off-farm sale, the land areas involved can be quite limited because management is focused on animal production. The cash crop farm and the intensive livestock farm are connected by the flow of feed, but nutrients typically do not cycle back to their original locations. This will usually result in an excess of nutrients on the farm where the animals are located and a high potential for environmental problems there.

For example the poultry layer farm illustrated in Table 1.4 has an excess of 2350 lb P₂O₅/A/year. The field-based economic and agronomic incentives that can be effective in motivating farmers to manage nutrients on a cash crop farm (and that will also minimize potential environmental impacts) are not as critical on the intensive livestock production-oriented farm. It is unlikely that

environmental quality can be protected on poultry and swine farms solely by recycling nutrients for crop production because of the small land area of the farm. Successful management of nutrients to protect the environment will depend on transportation of manure nutrients from the farm.

Note: Animal concentration areas

The number of animals in barnyards and holding areas can be greater on intensive livestock farms because ruminant animals often spend part of their time out of buildings. The result is that the areas around farmyard facilities can become sources of nutrient losses from the farm. Animal concentration areas are such locations where the animals gather and deposit manure nutrients in quantities that exceed removal in growing vegetation. These areas often have little or no vegetation and may be located in environmentally sensitive areas, such as stream bottomland. These areas require special attention in nutrient management plans and usually require BMP (*Best Management Practices*) to protect water quality.

Table 1.4. Example of nutrient balance on a poultry layer farm in Pennsylvania.

Inputs:	lb P₂O₅/A/yr
Fertilizer	0
Feed	3380
Output:	
Eggs	1030
Balance	+2350

Nutrient management planning

Purpose of nutrient management

Nutrient management is the implementation of practices that permit efficient crop production while protecting water quality from nutrient pollution. A *nutrient management plan* is a site-specific plan whose recommendations permit efficient nutrient use by crops and minimize nutrient losses to the environment (primarily water and air). Some amount of nutrient loss will occur even when the best nutrient management practices are employed, but these losses should be lower than would occur without nutrient management.

The nutrient management process

Nutrient management should be planned as a multi-step, constantly evolving process. The key components of the process are: **assessment, management option selection, planning, implementation, and record keeping** (Figure 1.7).

Figure 1.7. The nutrient management process.

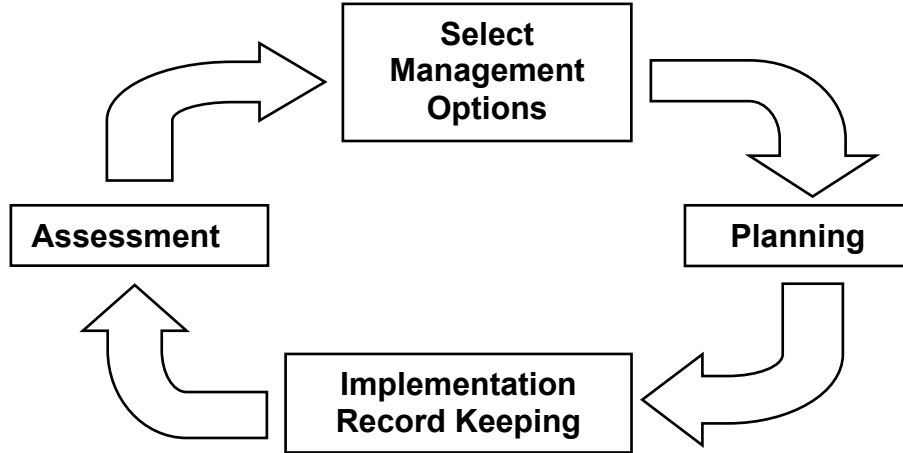

Nutrient management assessment I: nutrient status and balance

A thorough assessment of the nutrient status of the farm and the potential for environmental impacts from nutrients should be conducted. Key criteria should include:

- farm management goals and constraints.
- available farm resources (land, equipment, and financial resources.)
- potential critical problem areas on the farm (sensitive water bodies, neighbor concerns, existing problems such as barnyards, severe erosion, manure storage, etc.)
- nutrient balance.

Nutrient balance can be estimated from easily determinable farm characteristics. Table 1.5 provides some simple criteria that can be used to assess farm nutrient balance. These are estimates only, and actual nutrient balance will vary depending on specific farm characteristics.

Table 1.5. On-farm criteria that can be used to estimate nitrogen¹ balance.

Criteria	Farm is deficient in N	Farm has balanced N	Farm has excess N
Feed Source (% off farm feed)	On farm (<50%)	Combination (50 – 80%)	Off-farm (>80%)
Animal Density (AU/A²)	Low (<1.25 AU/A)	Medium (1.25-2.25 AU/A)	High (>2.25 AU/A)
Pollution Potential³	Low	Medium	High

¹ To estimate P balance, these numbers can be cut in half

² AU = Animal unit = 1000 lb live weight; A = Acres available for manure application

³ Assuming good management

Nutrient management assessment II: sites which may have accelerated nutrient loss

The potential for plant nutrients (particularly N and P) to migrate to surface water and groundwater is largely dependent upon soil and site conditions. Any combination of soil and site conditions that will lead to either rapid rainfall runoff or rapid movement of dissolved ions through the soil will lead to water quality risks from almost any land use practice. Thus, an important part of nutrient management planning for agriculture is recognizing and delineating these sites for development of specific management practices to avoid the anticipated effects.

The following soil/landscape features and properties are particularly vulnerable to the loss of nutrients from agricultural practices:

• **Soils with high leaching potentials:**

This includes soils with very coarse textures and those where the water table is at or near the surface during the winter. The combination of these factors poses a high risk for nutrient loss to groundwater and associated surface waters. If accurate soil survey information is available, the leaching index for a given soil can be obtained by following the procedures outlined in the U.S. Department of Agriculture National Resources Conservation Service (USDA-NRCS) Field Office Technical Guide (available at <http://www.nrcs.usda.gov/technical/efotg/>).

Such soils should not receive nutrient applications during times of the year when nutrients are least likely to be assimilated by crops (i.e., late fall, winter). Nutrient management practices in fields containing significant areas of these soils should include such practices as split application of N on crops and the use of winter cover crops to scavenge residual soil N.

- **Karst lands (landscapes underlain by limestone bedrock or other highly soluble carbonate-bearing parent materials):**

Sinkholes are formed by the long-term dissolution of carbonates underlying the surface, which eventually leaves a cavity that collapses over time. These areas mainly occur in the Valley and Ridge Physiographic Province (see Chapter 2), but may also occur in the lower Coastal Plain.

Sinkholes may form a direct connection between surface water and groundwater, and dye tracer tests have shown that water entering a sinkhole can contaminate nearby drinking wells within hours. If muddy or cloudy water appears in a well after a significant rain, surface water is likely entering the water bearing zones in the rock by direct flow down channels and rock fractures.

If a sinkhole is located in an isolated high area of a field, a grassed buffer should be placed around it. If the sinkhole occurs on a sideslope or below a cropped field, significant runoff may drain into the sinkhole. The field area draining into the sinkhole would be best used for hay crops, pasture, or trees, in order to reduce runoff.

- **Shallow soils over fractured bedrock:**

Soils that are shallow (less than 41 inches) to fractured bedrock are environmentally sensitive and should be managed like soils with a high leaching index. Although many of these soils do not have high leaching potential, once the soil water percolates to the fractured rock, the water and any dissolved nutrients can move rapidly to groundwater.

Lists of shallow soils in each state can be obtained from the NRCS and by reviewing county soil survey reports. Nutrient management practices in fields containing significant areas of these soils should include such practices as split application of N on crops and the use of winter cover crops to scavenge residual soil N.

- **Tile-drained lands:**

Artificially drained fields should be treated as environmentally sensitive because of the direct connection of the tile outlets to surface watersheds. These lands are typically drained because they have a high seasonal water table and, therefore, have the potential to pollute both the surface water with their drainage discharge and the local water table if nutrients are over-applied relative to crop uptake. These soils should be treated like coarse-textured soils with high water tables. Nutrient management practices in fields containing significant areas of tile-drained soils should include split application of N on crops and the use of winter cover crops to scavenge residual soil N.

- **Irrigated lands:**

Fields receiving irrigation, because of the increased water input, are prone to runoff and leaching of water and nutrients. The leaching index approach cannot be used on these areas since it would underestimate the actual leaching potential. To maximize water use efficiency and minimize leaching and runoff, irrigation scheduling methods should be used. These include the use of gypsum blocks, tensiometers, or computerized systems. When these indicators show the need for irrigation, rates and amounts of water should be based upon the soil type and water-holding capacity to further reduce water and nutrient losses.

- **Excessively sloping lands:**

Lands with steep and long slopes pose a high risk for the surface loss of applied nutrients. Slopes greater than 12% to 15% are prone to runoff losses of surface-applied N and P. Significant amounts of sediment can be lost if a heavy rainfall event occurs following tillage to move these surface-applied nutrients below the flow of runoff. Applications of manure or biosolids may be limited to P soil test needs or crop uptake estimates, unless injection is used, if these organic by-products are applied to such slopes. Soil conservation measures should be practiced on highly erodible lands.

- **Flood plains and other lands near surface waters:**

Runoff and leaching from agricultural lands that are close to surface waters can have a direct impact on surface water quality. If channelized flow develops, surface flow of runoff water from these areas has little chance to be filtered before discharge into adjacent waters. Subsurface flow in groundwater can also directly seep into the adjacent surface water body. If water containing NO_3^- flows into a wetland, however, significant amounts of N can be denitrified and lost to the atmosphere, with a subsequent reduction in the N levels that reach the adjacent surface waters.

Using manure or biosolids on flood plains is not a recommended practice. If manure or biosolids must be applied to a flood plain, incorporation or injection application methods should be used to minimize losses if flooding occurs.

The list of environmentally sensitive sites given above is not all-inclusive but does include the major types of land with these concerns in the region. Appropriate setback or buffer areas should be established between these areas and any field receiving nutrient applications, and intensive nutrient management practices should be employed on any lands adjacent to sensitive areas. Each state has its own guidelines for these buffer areas as well as regional guidelines such as those associated with the various Chesapeake Bay initiatives.

**Selecting
management
options**

After the nutrient management assessment of the farm, appropriate management options can then be selected for inclusion in the nutrient management plan. Each farm will have unique qualities, resources, and problems that must be addressed in the nutrient management plan.

Management options that maximize nutrient use efficiency by the crops and reduce the need to purchase nutrients would be emphasized on a farm that is nutrient deficient. On a farm with excess nutrients, practices that maximize safe utilization and off-farm distribution of nutrients would be emphasized. For example, spreading manure onto alfalfa would not be a recommended practice on a farm with a deficit of nitrogen because this would be an inefficient use of the manure N; however, spreading manure on alfalfa may be recommended to safely utilize the manure on a farm with excess nitrogen.

Table 1.6 summarizes important considerations in selecting appropriate management options depending on the assessment outcome. Notice that the economics of improved nutrient management are not always positive. In fact, on farms that have excessive nutrients, improving the nutrient management usually results in a negative economic return. This is a common misunderstanding by people who think that improved nutrient management will always give a positive economic return. Farmers would likely have already adopted the practices if the economics were positive.

Table 1.6. Selecting management options depending on nutrient balance from the nutrient balance assessment.

Option	Nutrient Balance Assessment		
	Deficient in Nutrients	Balanced Nutrients	Excess Nutrients
Management emphasis	Maximize nutrient use efficiency	Maximize safe nutrient utilization	Maximize safe nutrient utilization and move excess nutrients off farm
Land available for spreading manure	Adequate	Adequate but limited	Inadequate
Basis for manure application	Optimum crop response	Balance nutrient inputs and outputs	Balance nutrient inputs and outputs by exporting nutrients
Economics	Positive	Neutral	Negative

Nutrient management planning

Nutrient management planning involves integrating the management options based on the assessment into a comprehensive tactical and operational plan. The nutrient management planning process is dependent upon the synthesis of information and data on the soils, cropping systems, nutrient amendments, management practices, and climate; therefore, care should be taken to ensure that the information used to develop the nutrient management plan is current and accurate.

Nutrient management plans must be tailored to specific soils and crop production systems. While each state in our region may have differing approaches to this process, the following steps will generally be essential.

Nutrient Management Planning	
Step	Action
1	Obtain accurate soil information for each field or management unit by analyzing representative soil samples from each management unit. This may require a new farm soil map or a revision of existing USDA-NRCS mapping coverage.

2	Determine the crop yield potential for each field based on the known productivity of the soils present coupled with the intended management practices.
3	Identify the total plant nutrient needs to achieve the expected yield potential. Usually this is based on the soil test recommendation.
4	Estimate the nutrient contribution that can be expected from residual effects or carryover from previous fertilizer, manure, or biosolids applications. Include credit for N supplied to a row crop following a previous legume.
5	Determine if any nutrients will be applied regardless of the manure application. Examples here might be starter fertilizers or fertilizers used as pesticide carriers.
6	<p>Calculate the rate of manure, composts or biosolids that would match or balance the net crop nutrient requirements.</p> <p style="text-align: center;">Net Nutrient Requirement = Total nutrient needs minus residuals from manure and legumes minus fertilizer to be applied regardless of manure.</p> <p>Usually this rate is calculated based on the net N or P requirement. If the rate is based on N, the availability of the manure N to crops must be considered in the calculation. The potential environmental risk from P applied at the N-based rate should be evaluated with the use of a tool such as the P Index if the rate is based on N. The calculated rate is often adjusted to make it more practical for the farmer. The practical rate should not exceed the calculated balanced rate.</p>
7	Recommend application timing and methods for manure, other organic nutrients, and/or commercial fertilizers to supply the needed nutrients at the appropriate time for optimal crop production.
8	Recommend appropriate management practices (e.g., tillage, irrigation, cropping system, buffer zones) to enhance the protection of surface water and groundwater.
9	Identify and plan treatment for sensitive areas whose characteristics may increase the risk of nutrient loss.

Implementation The nutrient management plan will not protect the environment unless it is implemented. **Thus, it is essential to work with the farmer to assure that the plan is practical.**

Keeping records Keeping records is often required by law, but recordkeeping is a critical process regardless of any legal requirement. The record provides accountability to the public and is the foundation for an assessment that will start the next nutrient management planning cycle. In the end, nutrient management planning should be a continuous process of assessing the implementation successes and failures, selecting new management options as appropriate, revising the plan, and implementing this revised plan. With time, the implementation should more closely match the plan.

Recordkeeping should be part of the plan to facilitate the process. For example, it is easy for the farmer to acknowledge that a component of the plan was completed as planned, or to note that something was done differently, if space for records is included in the operational summary of the plan that the farmer will follow.

Table 1.7 is an excerpt from a nutrient management plan manure application summary which includes the records of what was done. In this example, manure to be applied for corn should be incorporated within 4-7 days after application, but the record shows that it was not incorporated. If this continues to be a common occurrence, incorporation may be omitted in future plans.

Table 1.7. Excerpt from an example nutrient management plan manure application summary illustrating how the record can be integrated into the plan summary.

Field	Acres	Crop	Fertilizer	Actual	Type	Rate	Time	Method	Actual
1	10	Corn	10-20-10 Starter	Done 4/29.	Dairy	5000 gal/A	Spring	Surface incorporate within 4-7 days	Done 4/10. Not incorporated.
2	10	Hay	0-50-150	Applied 150 lb 0-0-60/A plus manure.					Applied 3000 gal dairy manure after first cutting 6/7.
3	10	Corn	10-20-10 Starter	Done 5/2.	Dairy	5000 gal/A	Spring	Surface incorporate within 4-7 days	Done 4/17. Not incorporated.

References cited

Daniel, T.C., A.N. Sharpley, and J.L. Lemunyon. 1998. Agricultural phosphorus and eutrophication: A symposium overview. *J. Environ. Qual.* 27:251-257.

L'Hirondel, J.L., T.M. Addiscott, and A.A. Avery. 2005. Nitrate limits – Based on myth or fact? Presentation No. 204-6. Symposium on Nitrogen and Human Health. ASA, CSSA, and SSSA International Meetings, Salt Lake City, UT. Nov. 6-10. Available on-line at: <http://a-c-s.confex.com/a-c-s/2005am/techprogram/P8047.HTM>.

Meybeck, M. 1982. Carbon, nitrogen, and phosphorus transport in world rivers. *Am. J. Sci.* 282:401-450.

Sharpley, A.N., T.C. Daniel, J.T. Sims, and D.H. Pote. 1996. Determining environmentally sound soil phosphorus levels. *J. Soil and Water Cons.* 51(2):160-166.

Smith, R.A. and R.B. Alexander. 2000. Sources of nutrients in the nation's watersheds. p. 13-21. In National Resource, Agriculture, and Engineering Service (ed.) Proceedings of a conference for nutrient management consultants, extension educators, and producer advisors. NRAES-130. Camp Hill, PA. March 28-30.

Spalding, R.F. and M.E. Exner. 1993. Occurrence of nitrate in groundwater – A review. *J. Environ. Qual.* 22:392-402.

U.S. EPA. 1983. Chesapeake Bay Program: Findings and recommendations. U.S. Environmental Protection Agency, Region III, Philadelphia, PA.

U.S. EPA. 1990. National pesticide survey. Summary results of EPA's national survey of pesticides in drinking water wells. Draft 31 Oct. 1990. U.S. Environmental Protection Agency, Washington, DC.

U.S. EPA. 1998. National water quality inventory. EPA 841-R-97-008. U.S. Environmental Protection Agency, Washington, DC.

Zygmunt, H. 2000. Nutrients and water quality. p. 3-12. In National Resource, Agriculture, and Engineering Service (ed.) Proceedings of a conference for nutrient management consultants, extension educators, and producer advisors. NRAES-130. Camp Hill, PA. March 28-30.

Chapter 2. Regional Landscapes and the Hydrologic Cycle

W. Lee Daniels

Department of Crop and Soil Environmental Sciences, Virginia Tech

Table of Contents

Introduction.....	23
Soils and landscapes of the Mid-Atlantic region	23
Physiographic provinces	23
Atlantic Coastal Plain	24
Piedmont	25
Blue Ridge	25
Ridge and Valley.....	25
Appalachian Plateau.....	26
Exceptions.....	26
The hydrologic cycle and soil-water balances	27
Introduction.....	27
Precipitation	28
Evapo-transpiration.....	28
Surface runoff, interception, and leaching.....	28
Discharge of groundwater into streams (base flow)	28
References cited.....	30

Introduction

The relative risk of nutrient movement to groundwater and surface waters in any soil landscape is strongly controlled by the nature of the underlying parent material. Differing parent materials weather into varied landforms and associated soil types. These are then affected by management practices, resulting in different infiltration and runoff rates. These differences in local soil hydrologic character directly influence field level runoff behavior and the degree to which percolating leaching waters are filtered through reactive subsoils before they reach groundwater discharge points.

Soils and landscapes of the Mid-Atlantic region

Physiographic provinces

The surface soil landscape of the Mid-Atlantic region is dominated by its underlying geology that in turn controls regional landforms. The Mid-Atlantic possesses five unique physiographic provinces (Figure 2.1) related to the underlying geologic formations and associated landforms. Going from east to west, these provinces are the Atlantic Coastal Plain, the Piedmont, the Blue Ridge, the Ridge and Valley, and finally, the Appalachian Plateau. Soils vary considerably from province to province, as do their related nutrient management concerns. Basic soil/parent material relationships and how they interact with important watershed and nutrient management issues are discussed below.

Figure 2.1. Physiographic provinces of the Mid-Atlantic region.

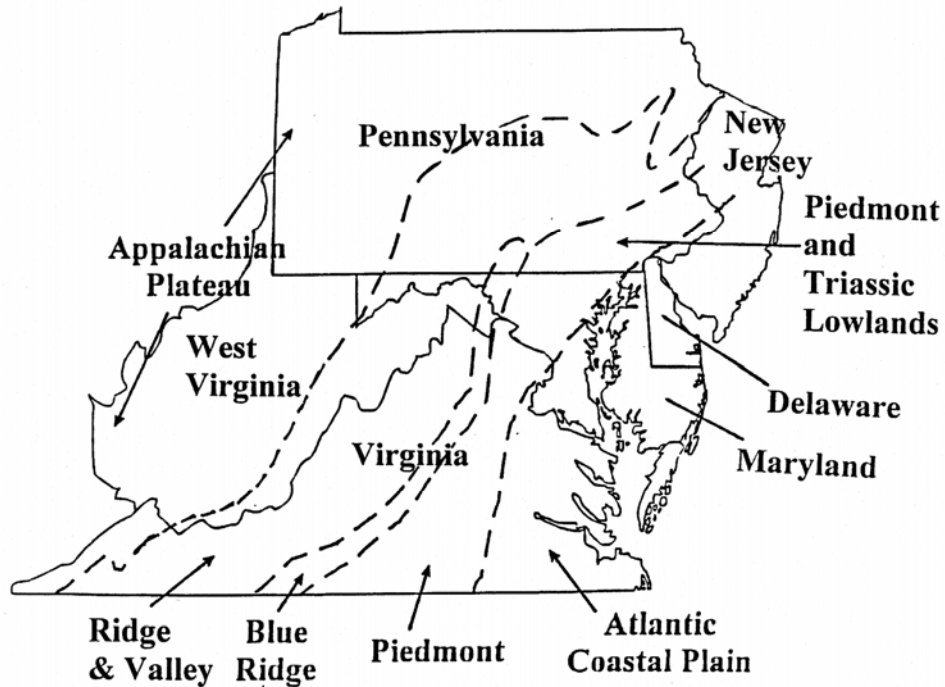

Atlantic Coastal Plain

The *Atlantic Coastal Plain* Province extends from the Eastern shore to its western boundary with the Piedmont at the Fall Zone. Baltimore, Richmond, and several other major cities are located on the Fall Line of rivers that occurs within the broader Fall Zone. The Coastal Plain is composed almost entirely of unconsolidated fluvio-marine sediments that are predominantly sandy in original texture. Significant deposits of finer textured silts and clays are found interbedded in the sediments along with occasional marl (shell/lime) and peat deposits. The Coastal Plain supports some of the Mid-Atlantic region's most intensive combined row crop/animal agriculture production systems, particularly on the Delmarva Peninsula and in Southside Virginia.

In general, the soils of the Coastal Plain are younger and sandier to the east and older and higher in clay to the west. The lower Coastal Plain landscapes to the east tend to be quite broad and undissected when compared to the higher landscapes associated with the Upper Coastal Plain. Many soils in the Lower Coastal Plain are quite wet and have been drained for agricultural production. These soils and those lying immediately adjacent to the waters of the Chesapeake Bay are environmentally sensitive and demand careful nutrient management.

Many Coastal Plain soils are also very sandy in texture and therefore have high leaching potentials. However, many of these sandy surface soils are

underlain by clay-enriched subsoils that can scavenge and hold nutrient cations. Moderate to steep slopes are encountered to some extent in the Middle and Upper Coastal Plain, particularly in areas adjacent to active streams.

Piedmont

The *Piedmont* Province is underlain by igneous and metamorphic rocks weathered for long periods into soft weathered rock, or *saprolite* that comprise the soil's parent material. In general, the soils are deep, have high clay content, and are commonly severely eroded.

The Piedmont landscape is a randomly dissected plain with a gentle slope from the base of the Blue Ridge to the Fall Zone. Large, flat areas are uncommon in the Piedmont, and most agricultural fields are located in the moderately sloping summit and shoulder positions of the local landscape. The local geology of the Piedmont can be quite complex, and shallow, rocky soils are often intermixed with less management-sensitive soils. Soil wetness is generally a problem only in areas immediately adjacent to streams, although upland wetlands do occur in the Piedmont, particularly in flatter summit areas underlain by high clay soils.

The Piedmont also contains a number of imbedded Triassic Basins that can be quite large. These basins contain soils formed in sediments or from sedimentary rock that resemble the soils of the Coastal Plain or the Appalachian Plateau.

Blue Ridge

The *Blue Ridge* Province occurs in a narrow strip associated with the Blue Ridge Front of the Appalachian Mountains and is underlain by complex metamorphic and igneous intrusive rocks. Most of the Blue Ridge is steep and rocky and not suited to agricultural production. The soils in these areas are typically shallow to bedrock. However, localized areas of the province are moderately rolling and highly resemble the Piedmont in their basic soil landscape characteristics. In these areas, forage and row-crop-based animal production systems are common and frequently intensive.

Ridge and Valley

The *Ridge and Valley* Province is underlain by folded and faulted rocks of sedimentary origin. The ridges are dominantly supported by harder, iron- and silica-rich rocks such as sandstones and are covered with shallow, rocky soils on steep slopes and deep loamy soils in coves. The valleys are generally underlain by limestones and carbonate-rich shales that have weathered into deep productive soils with silty surface layers and clayey subsoils. These limestone valleys, particularly from the Shenandoah River north through central Pennsylvania, support some of the most intensive row-crop and animal production agriculture in the Mid-Atlantic region.

Karst terrain and its associated sinkholes commonly occur throughout this province over the purer limestone parent materials. Karst areas require intensive nutrient management. Many soils in this province are also shallow over fractured rock and are, therefore, environmentally sensitive. The landscape over the limestones is typically moderately rolling, but excessively steep sideslopes and rock outcrops are also common.

Much of this valley landscape is overlain by river terrace deposits that are usually productive, but may contain significant amounts of cobblestones that can limit tillage. Poorly drained soils are typically confined to areas next to streams. Many soils of the Ridge and Valley Province are shallow to fractured rock, particularly those that have formed over shales and purer carbonates.

Appalachian Plateau

The *Appalachian Plateau* Province is a deeply dissected region underlain by flat-lying sedimentary rocks that are dominantly sandstones, siltstones, and shales. Thin coal seams are also common. The vast majority of this province is steeply sloping and covered with forest, although rolling uplands on the Plateau are farmed to a significant extent in western Pennsylvania and in some localized areas further south. Agriculture production activities are intensive in some areas, but most of the land in this province is used for non-agricultural uses. The soils are generally coarse textured and frequently shallow to rock. Much of this province in northwestern Pennsylvania has been covered by a mantle of till resulting from glaciation. The portions of this province to the south were not affected by glaciation.

Exceptions

Soils with contrasting characteristics to those described above may be found in any of the Mid-Atlantic physiographic provinces. For example, major river systems, such as the James and Susquehanna, cut through the provinces from west to east and have a unique set of floodplain and terrace soils associated with their historic paths. Very productive soils associated with relict river terraces are commonly found tens of miles away from current stream channels, particularly in the limestone valleys.

Many of the soils of the glaciated northwestern part of the Mid-Atlantic, which were formed in till and outwash, are considerably different from the soils formed in residual saprolite (weathered rock) further south. In areas such as the Ridge and Valley Province, the soil's parent material can change drastically over a distance of several feet, with associated changes in both soil properties and appropriate land use.

Detailed information on soils, geology, and land-use interactions is available from soil survey reports for most counties in the Mid-Atlantic region (<http://soils.usda.gov/>), and the reader is encouraged to consult this information before any significant project or planning process is undertaken.

The hydrologic cycle and soil-water balances

Introduction

A basic understanding of the hydrologic cycle (illustrated in Figure 2.2) is necessary to understand nutrient loss mechanisms and to develop management strategies to reduce nutrient losses to groundwater and surface water. The primary components of the hydrologic cycle most important to nutrient transport in groundwater and surface water are:

- precipitation
- evapotranspiration (evaporation + transpiration)
- surface runoff, interception, and leaching
- discharge of groundwater into streams (base flow)

Nutrients move into the groundwater system via leaching and to surface water via runoff or groundwater discharge. Any contaminants dissolved in surface runoff, such as NO_3^- , can contribute to surface water contamination. In addition, seepage of groundwater into surface water often occurs in stream beds and tidal portions of the Chesapeake Bay system.

Figure 2.2. The hydrologic cycle.

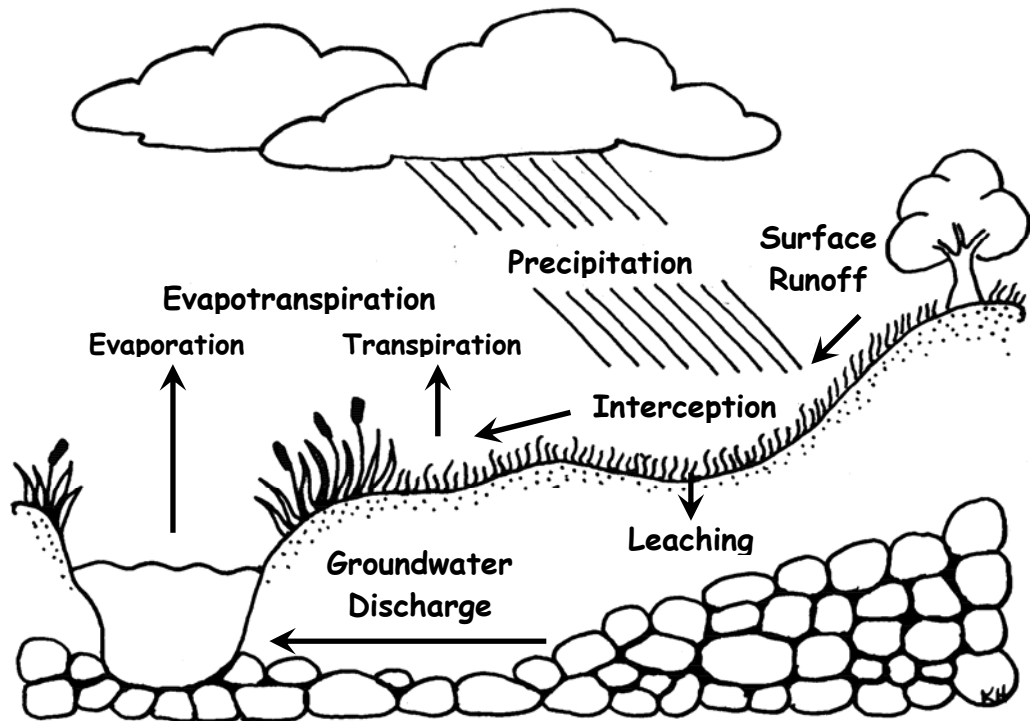

Precipitation Long-term *precipitation* averages range from 35 inches to over 50 inches annually in different areas of the Chesapeake Bay watershed. Although timing and amounts of precipitation will vary in each individual year, these deviations from the average cannot be reliably predicted in advance.

Evapo-transpiration *Evapotranspiration* is the sum of surface *evaporation* of moisture plus the removal of soil moisture by the *transpiration* of living vegetation. It accounts for about 20 inches to 35 inches of the total precipitation in the Chesapeake Bay watershed, and is highest when growing season air temperatures are highest, as long as the soil is fully vegetated. The removal of soil water by evapotranspiration decreases and net leaching increases when air temperatures drop below 40° F, or when an actively growing crop is removed.

Long-term average rainfall by month does not vary significantly throughout the year in the Mid-Atlantic region. Evapotranspiration, however, is much higher during the late spring, summer, and early fall because water use by crops is much higher during this period.

Surface runoff, interception, and leaching Precipitation that falls onto the soil surface in excess of the infiltration rate will *run off* to lower portions of the landscape or to surface streams. In vegetated areas, 5% to 40% of this precipitation is *intercepted* by the leaves of plants depending on the intensity of rainfall and the morphology of the canopy. Water that infiltrates the soil is largely removed by evapotranspiration during the growing season. Remaining soil water, particularly that held in large macropores, is subject to *leaching* below the rooting zone and may eventually reach groundwater. During leaching, soluble nutrients such as NO_3^- percolate through the soil with water because they are not readily bound to soil surfaces. The relative amounts of surface runoff, interception and leaching from an area are influenced by storm intensity, storm duration, slope, soil type, type of vegetation, and amount of residue.

Water losses to the atmosphere due to evapotranspiration during most of the active growing season will exceed rainfall contribution to soil moisture. Consequently, the risk of leaching or runoff of water is much lower during the summer than during the winter. During periods of low evapotranspiration, significant leaching and runoff can occur.

Discharge of groundwater into streams (base flow) Groundwater that infiltrates upland soils and then discharges into local streams is also termed *base flow*. The base flow in the specific Ridge and Valley Province watershed represented by Figure 2.3 accounts for about 5 inches per acre of watershed area, while direct surface flow accounts for 7 inches per acre annually. Surface flow contribution to stream water occurs

during and after rainfall events or snow melt and is, therefore, highly variable over time. In contrast, base flow is generally a continuous contributor to stream flow throughout the year. During dry periods, base flow is the primary contributor to stream flow, which vividly demonstrates the interconnection of groundwater and surface waters.

In the Piedmont Province, surface runoff of water is a larger contributor than base flow to surface water flow because of the topography and geology of the area.

In the Atlantic Coastal Plain Province, base flow and subsurface seepage of groundwater contribute more than surface runoff to surface water bodies. In some areas of the Coastal Plain, groundwater discharge may account for as much as 80% of total annual contributions to surface water due to the permeable soils and shallow groundwater that are characteristic of this physiographic province. Groundwater in the Coastal Plain Province typically moves in a downwardly arcing path from uplands towards discharge points at a rate of several inches to as much as 2 feet per day.

Figure 2.3. General water budget, Upper South Fork of the Shenandoah River (adapted from Virginia Division of Conservation and Recreation, 1993.)

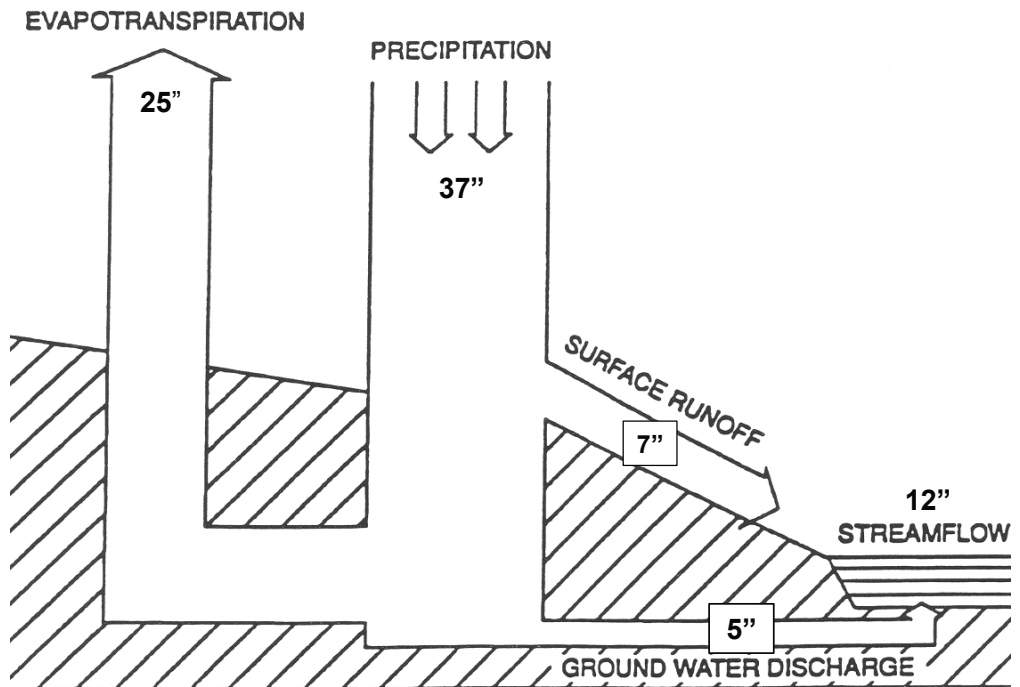

References cited

Virginia Department of Conservation and Recreation. 1993. Nutrient management handbook. 2nd edition. VA DCR, Richmond, VA.

Chapter 3. Concepts of Basic Soil Science

W. Lee Daniels

Kathryn C. Haering

Department of Crop and Soil Environmental Sciences, Virginia Tech

Table of Contents

Soil formation and soil horizons	33
Introduction.....	33
Soil composition by volume	33
Soil formation	34
Soil horizons	34
Soil physical properties.....	37
Introduction.....	37
Texture	37
Determining textural class with the textural triangle.....	38
Effects of texture on soil properties	39
Aggregation and soil structure	40
Effects of structure on soil properties	41
Porosity	42
Soil organic matter.....	43
Introduction.....	43
Factors that affect soil organic matter content.....	43
Effect of organic matter on soil properties	43
Soil-water relationships	44
Water-holding capacity.....	44
Field capacity and permanent wilting percentage.....	44
Tillage and moisture content.....	44
Soil drainage	45
Soil drainage and soil color.....	45
Drainage classes.....	46
Soil chemical properties.....	46
Introduction.....	46
Soil pH	47
Cation exchange capacity (CEC).....	47
Sources of negative charge in soils.....	48
Cation mobility in soils.....	48
Effect of CEC on soil properties	49
Base saturation	49
Buffering capacity.....	49
Soil survey	50
Introduction.....	50
Parts of a soil survey.....	50
Terminology used in soil surveys	50

Using a soil survey.....	51
References cited.....	52
References for additional information	52

Soil formation and soil horizons

Introduction

Soil covers the vast majority of the exposed portion of the earth in a thin layer. It supplies air, water, nutrients, and mechanical support for the roots of growing plants. The productivity of a given soil is largely dependent on its ability to supply a balance of these factors to the plant community.

Soil composition by volume

A desirable surface soil in good condition for plant growth contains approximately 50% solid material and 50% pore space (Figure 3.1). The solid material is composed of mineral material and organic matter. Mineral material comprises 45% to 48% of the total volume of a typical Mid-Atlantic soil. About 2% to 5% of the volume is made up of organic matter, which may contain both plant and animal residues in varying stages of decay or decomposition. Under ideal moisture conditions for growing plants, the remaining 50% soil pore space would contain approximately equal amounts of air (25%) and water (25%).

Figure 3.1. Volume composition of a desirable surface soil.

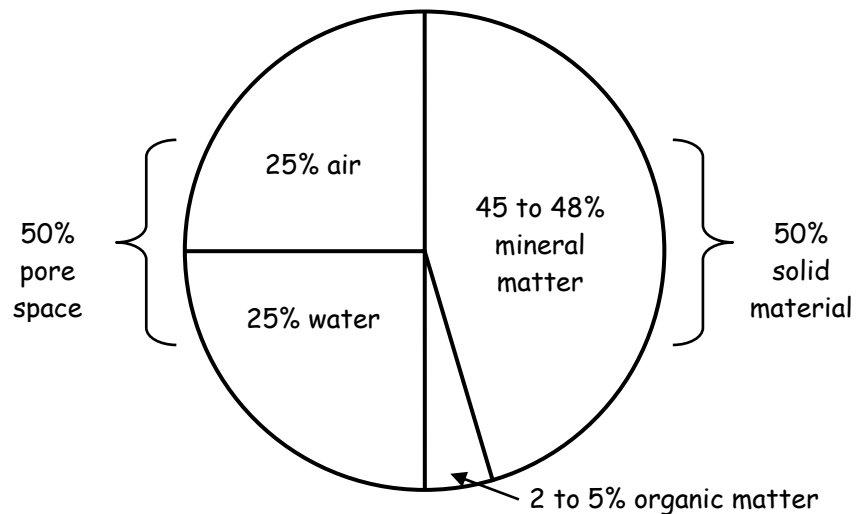

Soil formation The mineral material of a soil is the product of the weathering of underlying rock in place, or the weathering of transported sediments or rock fragments. The material from which a soil has formed is called its *parent material*. The weathering of residual parent materials to form soils is a slow process that has been occurring for millions of years in most of the Mid-Atlantic region. However, certain soil features (such as A horizons, discussed below) can form in several months to years.

The rate and extent of weathering depends on:

- the chemical composition of the minerals that comprise the rock or sediment
- the type, strength, and durability of the material that holds the mineral grains together
- the extent of rock flaws or fractures
- the rate of leaching through the material
- the extent and type of vegetation at the surface

Physical weathering is a mechanical process that occurs during the early stages of soil formation as freeze-thaw processes and differential heating and cooling breaks up rock parent material. After rocks or coarse gravels and sediments are reduced to a size that can retain adequate water and support plant life, the rate of soil formation increases rapidly. As organic materials decompose, the evolved carbon dioxide dissolves in water to form carbonic acid, a weak acid solution. The carbonic acid reacts with and alters many of the primary minerals in the soil matrix to make finer soil particles of sand, silt, and secondary clay minerals.

As soil-forming processes continue, some of the fine clay soil particles (<0.002 mm) are carried, or leached, by water from the upper or surface soil into the lower or subsoil layers. As a result of this leaching action, the surface soil texture becomes coarser and the subsoil texture becomes finer as the soil weathers.

Soil horizons Soils are layered because of the combined effects of organic matter additions to the surface soil and long-term leaching. These layers are called *horizons*. The vertical sequence of soil horizons found at a given location is collectively called the *soil profile* (Figure 3.2).

The principal master soil horizons found in managed agricultural fields are:

- A horizon or mineral surface soil (if the soil has been plowed, this is called the Ap horizon)
- B horizon or subsoil

- C horizon or partially weathered parent material
- rock (R layer) or unconsolidated parent materials similar to that from which the soil developed

Unmanaged forest soils also commonly contain an organic O horizon on the surface and a light-colored leached zone (E horizon) just below the A horizon.

The surface soil horizon(s) or *topsoil* (the Ap or A+ E horizons) is often coarser than the subsoil layer and contains more organic matter than the other soil layers. The organic matter imparts a grayish, dark-brownish, or black color to the topsoil. Soils that are high in organic matter usually have dark surface colors. The A or Ap horizon tends to be more fertile and have a greater concentration of plant roots of any other soil horizon. In unplowed soils, the *eluviated* (E) horizon below the A horizon is often light-colored, coarser-textured, and more acidic than either the A horizon or the horizons below it because of leaching over time.

The subsoil (B horizon) is typically finer in texture, denser, and firmer than the surface soil. Organic matter content of the subsoil tends to be much lower than that of the surface layer, and subsoil colors are often stronger and brighter, with shades of red, brown, and yellow predominating due to the accumulation of iron coated clays. Subsoil layers with high clay accumulation relative to the A horizon are described as Bt horizons.

The C horizon is partially decomposed and weathered parent material that retains some characteristics of the parent material. It is more like the parent material from which it has weathered than the subsoil above it.

Figure 3.2. Soil profile horizons.

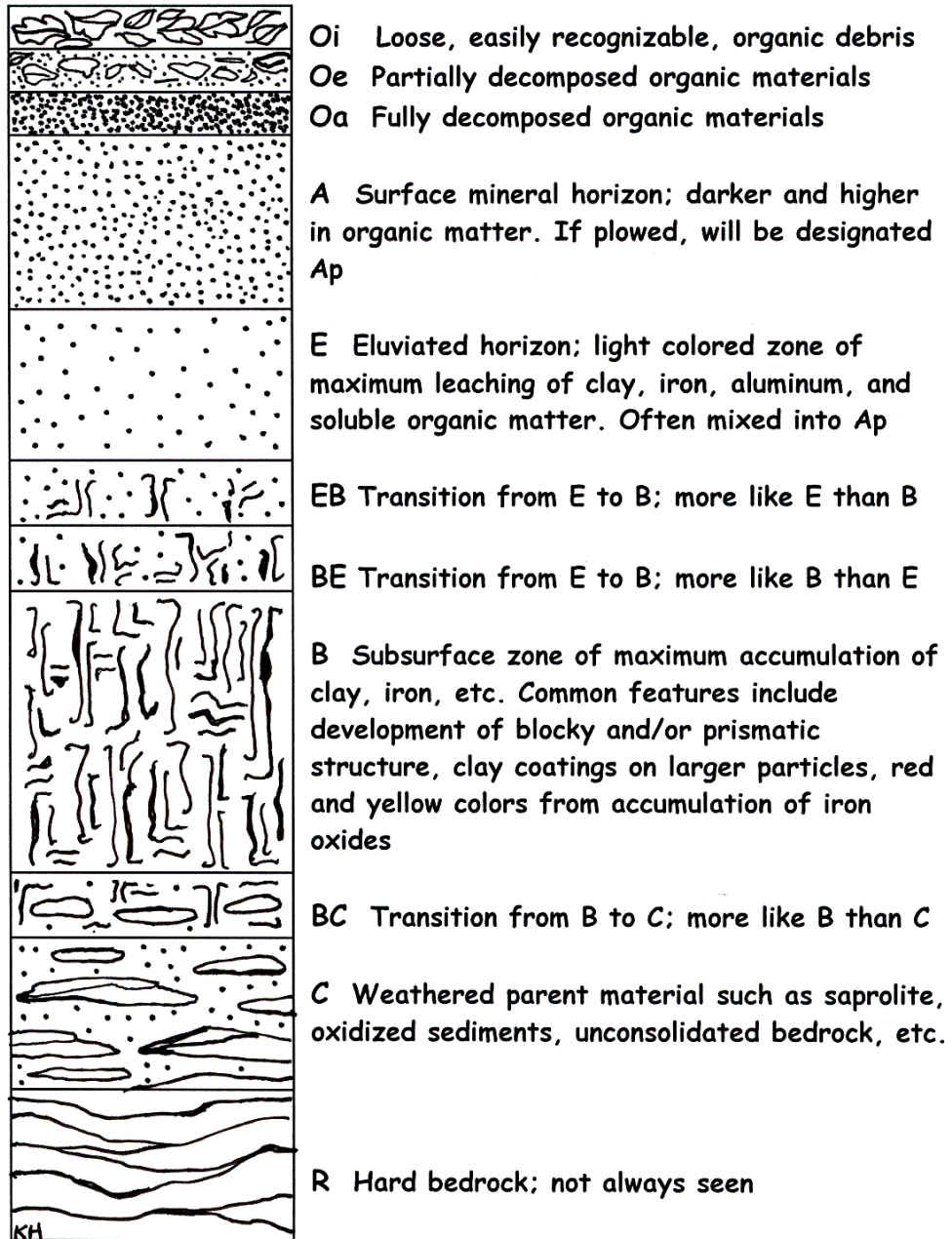

Soil physical properties

Introduction

The physical properties of a soil are the result of soil parent materials being acted upon by climatic factors (such as rainfall and temperature), and being affected by relief (slope and direction or aspect), and by vegetation, with time. A change in any one of these soil-forming factors usually results in a difference in the physical properties of the resulting soil.

The important physical properties of a soil are:

- texture
 - aggregation
 - structure
 - porosity
-

Texture

The relative amounts of the different soil size (<2 mm) particles, or the fineness or coarseness of the mineral particles in the soil, is referred to as soil texture. Mineral grains which are >2 mm in diameter are called rock fragments and are measured separately. Soil texture is determined by the relative amounts of *sand*, *silt*, and *clay* in the fine earth (< 2 mm) fraction.

- *Sand* particles vary in size from very fine (0.05 mm) to very coarse (2.0 mm) in average diameter. Most sand particles can be seen without a magnifying glass. Sands feel coarse and gritty when rubbed between the thumb and fingers, except for mica flakes which tend to smear when rubbed.
 - *Silt* particles range in size from 0.05 mm to 0.002 mm. When moistened, silt feels smooth but is not slick or sticky. When dry, it is smooth and floury and if pressed between the thumb and finger will retain the imprint. Silt particles are so fine that they cannot usually be seen by the unaided eye and are best seen with the aid of a strong hand lens or microscope.
 - *Clay* is the finest soil particle size class. Individual particles are finer than 0.002 mm. Clay particles can be seen only with the aid of an electron microscope. They feel extremely smooth or powdery when dry and become plastic and sticky when wet. Clay will hold the form into which it is molded when moist and will form a long ribbon when extruded between the fingers.
-

Determining textural class with the textural triangle

There are 12 primary classes of soil texture defined by the USDA (Soil Survey Division Staff, 1993). The textural classes are defined by their relative proportions of sand, silt, and clay as shown in the USDA *textural triangle* (Figure 3.3). Each textural class name indicates the size of the mineral particles that are dominant in the soil. Regardless of textural class, all soils in the Mid-Atlantic region contain sand, silt, and clay- sized particles, although the amount of a particular particle size may be small.

Texture can be estimated in the field by manipulating and feeling the soil between the thumb and fingers, but should be quantified by laboratory particle size analysis.

To use the textural triangle:

1. First, you will need to know the percentages of sand, silt, and clay in your soil, as determined by laboratory particle size analysis.
2. Locate the percentage of clay on the left side of the triangle and move inward horizontally, parallel to the base of the triangle.
3. Follow the same procedure for sand, moving along the base of the triangle to locate your sand percentage
4. Then, move up and to the left until you intersect the line corresponding to your clay percentage value.
5. At this point, read the *textural class* written within the bold boundary on the triangle. For example: a soil with 40% sand, 30% silt, and 30% clay will be a clay loam. With a moderate amount of practice, soil textural class can also be reliably determined in the field.

If a soil contains 15% or more rock fragments, a rock fragment content modifier is added to the soil's texture class. For example, the texture class designated as *gravelly silt* loam would contain 15 to 35% gravels (> 2 mm) within a silt loam (< 2 mm) fine soil matrix. More detailed information on USDA particle size classes and other basic soil morphological descriptors can be found on-line at <http://soils.usda.gov/technical/handbook/download.html> or in the USDA Soil Survey Manual (Soil Survey Division Staff, 1993).

Figure 3.3. The USDA textural triangle (Soil Survey Division Staff, 1993).

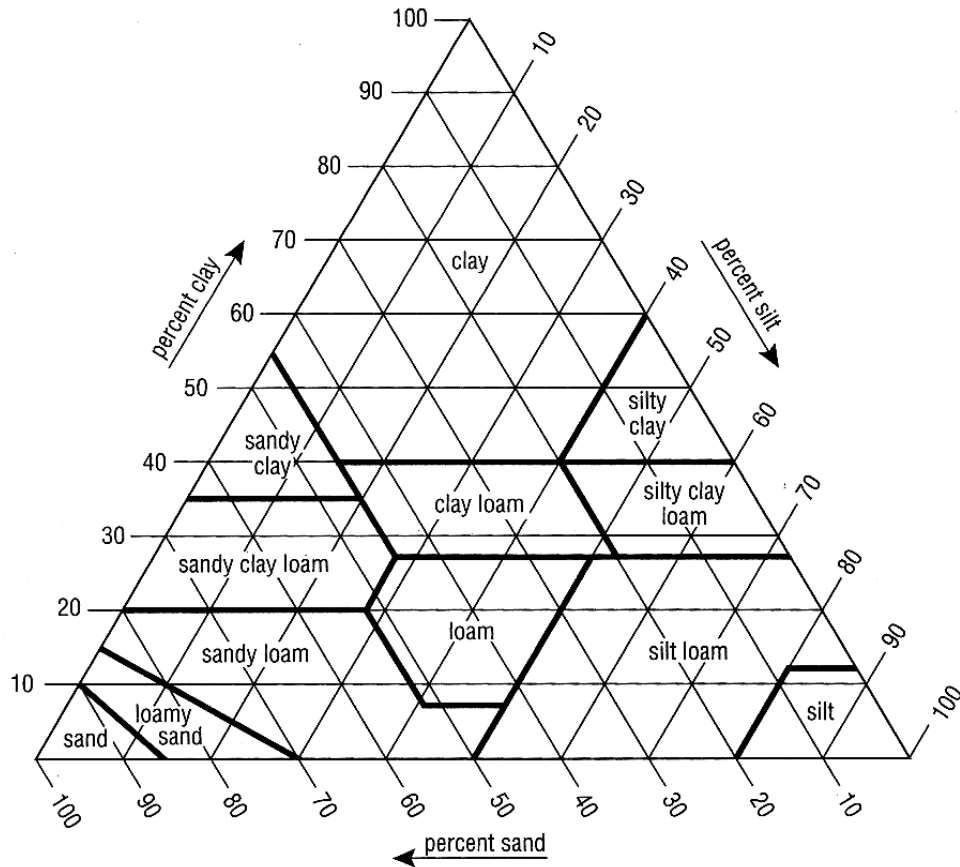

Effects of texture on soil properties

Water infiltrates more quickly and moves more freely in coarse-textured or sandy soils, which increases the potential for leaching of mobile nutrients. Sandy soils also hold less total water and fewer nutrients for plants than fine-textured soils. In addition, the relatively low water holding capacity and the larger amount of air present in sandy soils allows them to warm faster than fine-textured soils. Sandy and loamy soils are also more easily tilled than clayey soils, which tend to be denser.

In general, fine-textured soils hold more water and plant nutrients and thus require less frequent applications of water, lime, and fertilizer. Soils with high clay content (more than 40% clay), however, actually hold less plant-available water than loamy soils. Fine-textured soils have a narrower range of moisture conditions under which they can be worked satisfactorily than sandy soils. Soils high in silt and clay may puddle or form surface crusts after rains, impeding seedling emergence. High clay soils often break up into large clods when worked while either too dry or too wet.

Aggregation and soil structure

Soil *aggregation* is the cementing of several soil particles into a secondary unit or aggregate. Soil particles are arranged or grouped together during the aggregation process to form structural units (known to soil scientists as *peds*). These units vary in size, shape, and distinctness (also known as strength or grade).

The types of soil structure found in most Mid-Atlantic soils are described in Table 3.1 and illustrated in Figure 3.4.

Table 3.1. Types of soil structure.

Structure type	Description
Granular	Soil particles are arranged in small, rounded units. Granular structure is very common in surface soils (A horizons) and is usually most distinct in soils with relatively high organic matter content.
Blocky	Soil particles are arranged to form block-like units, which are about as wide as they are high or long. Some blocky peds are rounded on the edges and corners; others are angular. Blocky structure is commonly found in the subsoil, although some eroded fine-textured soils have blocky structure in the surface horizons.
Platy	Soil particles are arranged in plate-like sheets. These plate-like pieces are approximately horizontal in the soil and may occur in either the surface or subsoil, although they are most common in the subsoil. Platy structure strongly limits downward movement of water, air, and roots. Platy structure may occur just beneath the plow layer, resulting from compaction by heavy equipment, or on the soil surface when it is too wet to work satisfactorily.
Prismatic	Soil particles are arranged into large peds with a long vertical axis. Tops of prisms may be somewhat indistinct and normally angular. Prismatic structure occurs mainly in subsoils, and the prisms are typically much larger than other typical subsoil structure types such as blocks.
Structureless	Either: <ul style="list-style-type: none"> • <i>Massive</i>, with no definite structure or shape, as in some C horizons or compacted material. Or: <ul style="list-style-type: none"> • <i>Single grain</i>, which is typically individual sand grains in A or C horizons not held together by organic matter or clay.

Figure 3.4. Types of soil structure.

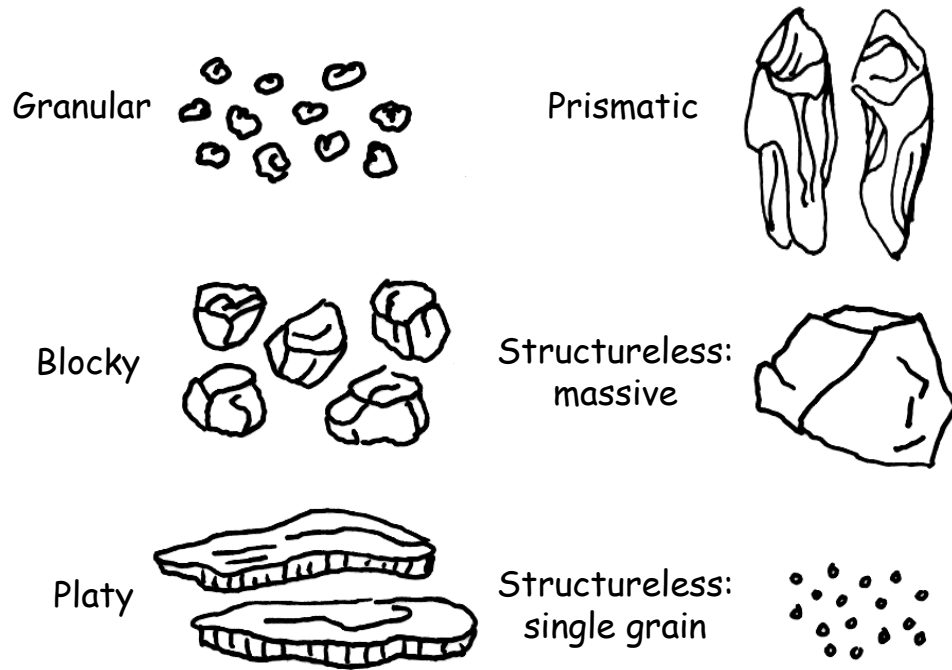

Effects of structure on soil properties

The structure of the soil affects pore space size and distribution and therefore, rates of air and water movement. Well-developed structure allows favorable movement of air and water, while poor structure retards movement of air and water. Since plant roots move through the same channels in the soil as air and water, well-developed structure also encourages extensive root development.

Water can enter a surface soil that has granular structure (particularly fine-textured soils) more rapidly than one that has relatively little structure. Surface soil structure is usually granular, but such granules may be indistinct or completely absent if the soil is continuously tilled, or if organic matter content is low.

The size, shape, and strength of subsoil structural pedes are important to soil productivity. Sandy soils generally have poorly developed structure relative to finer textured soils, because of their lower clay content. When the subsoil has well developed blocky structure, there will generally be good air and water movement in the soil. If platy structure has formed in the subsoil, downward water and air movement and root development in the soil will be slowed. Distinct prismatic structure is often associated with subsoils that swell when wet and shrink when dry, resulting in reduced air and water movement. Very large and distinct subsoil prisms are also commonly associated with *fragipans*, which are massive and dense subsoil layers.

Porosity

Soil *porosity*, or pore space, is the volume percentage of the total soil that is not occupied by solid particles. Pore space is commonly expressed as a percentage:

$$\% \text{ pore space} = 100 - [\text{bulk density} \div \text{particle density} \times 100]$$

Bulk density is the dry mass of soil solids per unit volume of soils, and *particle density* is the density of soil solids, which is assumed to be constant at 2.65 g/cm³. Bulk densities of mineral soils are usually in the range of 1.1 to 1.7 g/cm³. A soil with a bulk density of about 1.32 g/cm³ will generally possess the ideal soil condition of 50% solids and 50% pore space. Bulk density varies depending on factors such as texture, aggregation, organic matter, compaction/consolidation, soil management practices, and soil horizon.

Under field conditions, pore space is filled with a variable mix of water and air. If soil particles are packed closely together, as in graded surface soils or compact subsoils, total porosity is low and bulk density is high. If soil particles are arranged in porous aggregates, as is often the case in medium-textured soils high in organic matter, the pore space per unit volume will be high and the bulk density will be correspondingly low.

The size of the individual pore spaces, rather than their combined volume, will have the most effect on air and water movement in soil. Pores smaller than about 0.05 mm (or finer than sand) in diameter are typically called *micropores* and those larger than 0.05 mm are called *macropores*.

Macropores allow the ready movement of air, roots, and percolating water. In contrast, micropores in moist soils are typically filled with water, and this does not permit much air movement into or out of the soil. Internal water movement is also very slow in micropores. Thus, the movement of air and water through a coarse-textured sandy soil can be surprisingly rapid despite its low total porosity because of the dominance of macropores.

Fine-textured clay soils, especially those without a stable granular structure, may have reduced movement of air and water even though they have a large volume of total pore space. In these fine-textured soils, micropores are dominant. Since these small pores often stay full of water, aeration, especially in the subsoil, can be inadequate for root development and microbial activity. The loosening and granulation of fine-textured soils promotes aeration by increasing the number of macropores.

Soil organic matter

Introduction

Soil organic materials consist of plant and animal residues in various stages of decay. Primary sources of organic material inputs are dead roots, root exudates, litter and leaf drop, and the bodies of soil animals such as insects and worms. Earthworms, insects, bacteria, fungi, and other soil organisms use organic materials as their primary energy and nutrient source. Nutrients released from the residues through decomposition are then available for use by growing plants.

Soil *humus* is fully decomposed and stable organic matter. Humus is the most reactive and important component of soil organic matter, and is the form of soil organic material that is typically reported as “organic matter” on soil testing reports.

Factors that affect soil organic matter content

The organic matter content of a particular soil will depend on:

- **Type of vegetation:** Soils that have been in grass for long periods usually have a relatively high percentage of organic matter in their surface. Soils that develop under trees usually have a low organic matter percentage in the surface mineral soil, but do contain a surface litter layer (O horizon). Organic matter levels are typically higher in a topsoil supporting hay, pasture, or forest than in a topsoil used for cultivated crops.
 - **Tillage:** Soils that are tilled frequently are usually low in organic matter. Plowing and otherwise tilling the soil increases the amount of air in the soil, which increases the rate of organic matter decomposition. This detrimental effect of tillage on organic matter is particularly pronounced in very sandy well-aerated soils because of the tendency of frequent tillage to promote organic matter oxidation to CO₂.
 - **Drainage:** Soil organic matter is usually higher in poorly-drained soils because of limited oxidation, which slows down the overall biological decomposition process.
 - **Soil texture:** Soil organic matter is usually higher in fine-textured soils because soil humus forms stable complexes with clay particles.
-

Effect of organic matter on soil properties

Adequate soil organic matter levels benefit soil in several ways. The addition of organic matter improves soil physical conditions, particularly aggregation and pore space. This improvement leads to increased water infiltration, improved soil tilth, and decreased soil erosion. Organic matter additions also

improve soil fertility, since plant nutrients are released to plant-available mineral forms as organic residues are decomposed (or *mineralized*).

A mixture of organic materials in various states of decomposition helps maintain a good balance of air and water components in the soil. In coarse-textured soils, organic material bridges some of the space between sand grains, which increases water-holding capacity. In fine-textured soil, organic material helps maintain porosity by preventing fine soil particles from compacting.

Soil-water relationships

Water-holding capacity

Soil water-holding capacity is determined largely by the interaction of soil texture, bulk density/pore space, and aggregation. Sands hold little water because their large pore spaces allow water to drain freely from the soils. Clays adsorb a relatively large amount of water, and their small pore spaces retain it against gravitational forces. However, clayey soils hold water much more tightly than sandy soils, so that not all the moisture retained in clayey soils is available to growing plants. As a result, moisture stress can become a problem in fine-textured soils despite their high water-holding capacity.

Field capacity and permanent wilting percentage

The term *field capacity* defines the amount of water remaining in a soil after downward gravitational drainage has stopped. This value represents the maximum amount of water that a soil can hold against gravity following saturation by rain or irrigation. Field capacity is usually expressed as percentage by weight (for example, a soil holding 25% water at field capacity contains 25% of its dry weight as retained water).

The amount of water a soil contains after plants are wilted beyond recovery is called the *permanent wilting percentage*. Considerable water may still be present at this point, particularly in clays, but is held so tightly that plants are unable to extract it. The amount of water held by the soil between field capacity and the permanent wilting point is the *plant-available water*.

Tillage and moisture content

Soils with a high clay content are sticky when wet and form hard clods when dry. Tilling clayey soils at the proper moisture content is thus extremely important. Although sandy soils are inherently droughty, they are easier to till at varying moisture contents because they do not form dense clods or other high-strength aggregates. Sandy soils are also far less likely than clays to be compacted if cultivated when wet. However, soils containing high proportions of very fine sand may be compacted by tillage when moist.

Soil drainage

Soil drainage is the rate and extent of vertical or horizontal water removal during the growing season.

Important factors affecting soil drainage are:

- slope (or lack of slope)
- depth to the seasonal water table
- texture of surface and subsoil layers, and of underlying materials
- soil structure
- problems caused by improper tillage, such as compacted subsoils or lack of surface soil structure

Another definition of drainage refers to the removal of excess water from the soil to facilitate agriculture, forestry, or other higher land uses. This is usually accomplished through a series of surface ditches or the installation of subsoil drains.

Soil drainage and soil color

The nature of soil drainage is usually indicated by soil color patterns (such as mottles) and color variations with depth. Clear, bright red and/or yellow subsoil colors indicate well-drained conditions where iron and other compounds are present in their oxidized forms. A soil is said to be well-drained when the *solum* (A+E+B horizon) exhibits strong red/yellow colors without any gray mottles.

When soils become saturated for significant periods of time during the growing season, these oxidized (red/yellow) forms of iron are biochemically reduced to soluble forms and can be moved with drainage waters. This creates a matrix of drab, dominantly gray colors. Subsoil zones with mixtures of bright red/yellow and gray mottling are indicative of seasonally fluctuating water tables, where the subsoil is wet during the winter/early spring and unsaturated in the summer/early fall. Poorly drained soils also tend to accumulate large amounts of organic matter in their surface horizons because of limited oxidation and may have very thick and dark A horizons.

Soils that are wet in their upper 12 inches for considerable amounts of time during the growing season and that support hydrophytic vegetation typical of wetlands are designated as *hydric soils*. Drainage mottles in these soils are referred to as *redoximorphic features*. Further information on Mid-Atlantic hydric soils and redoximorphic features can be found on-line at <http://www.epa.gov/reg3esd1/hydricsoils/index.htm>.

Drainage classes

The *drainage class* of a soil defines the frequency of soil wetness as it limits agricultural practices, and is usually determined by the depth in soil to gray mottles or other redoximorphic features. The soil drainage classes in table 3.2 are defined by the USDA-NRCS. They refer to the natural drainage condition of the soil without artificial drainage.

Table 3.2. Soil drainage classes.

Drainage Class	Soil Characteristics	Effect on Cropping
Excessively drained	Water is removed rapidly from soil.	Will probably require supplemental irrigation.
Somewhat excessively drained		
Well drained	Water is removed readily, but not rapidly.	No drainage required.
Moderately well drained	Water is removed somewhat slowly at some periods of the year.	May require supplemental drainage if crops that require good drainage are grown.
Somewhat poorly drained	Water is removed so slowly that soil is wet at shallow depths periodically during the growing season.	Will probably require supplemental drainage for satisfactory use in production of most crops.
Poorly drained		
Very poorly drained		
	Free water is present at or near the surface during the growing season.	

Soil chemical properties

Introduction

The plant root obtains essential nutrients almost entirely by uptake from the soil solution. The chemistry and nutrient content of the soil solution is, in turn, controlled by the solid material portion of the soil. Soil chemical properties, therefore, reflect the influence of the soil minerals and organic materials on the soil solution.

Soil pH

Soil pH defines the relative acidity or alkalinity of the soil solution. The pH scale in natural systems ranges from 0 to 14. A pH value of 7.0 is neutral. Values below 7.0 are acid and those above 7.0 are alkaline, or basic. Many agricultural soils in the Mid-Atlantic region have a soil pH between 5.5 and 6.5.

Soil pH is a measurement of hydrogen ion (H^+) activity, or effective concentration, in a soil and water solution. Soil pH is expressed in logarithmic terms, which means that each unit change in soil pH amounts to a tenfold change in acidity or alkalinity. For example, a soil with a pH of 6.0 has 10 times as much active H^+ as one with a pH of 7.0.

Soils become acidic when basic cations (such as calcium, or Ca^{2+}) held by soil colloids are leached from the soil, and are replaced by aluminum ions (Al^{3+}), which then hydrolyze to form aluminum hydroxide ($Al(OH)_3$) solids and H^+ ions in solution. This long-term acidification process is accelerated by the decomposition of organic matter which also releases acids to soil solution. Most soils of the Mid-Atlantic were formed under high rainfall with abundant vegetation, and are therefore generally more acidic than soils of the midwestern and western United States.

Cation exchange capacity (CEC)

The net ability of a soil to hold, retain, and exchange *cations* (positively charged ions) such as calcium (Ca^{2+}), magnesium (Mg^{2+}), potassium (K^+), sodium (Na^+), ammonium (NH_4^+), aluminum (Al^{3+}), and hydrogen (H^+) is called *cation exchange capacity*, or *CEC*. All soils contain clay minerals and organic matter that typically possess negative electrical surface charges. These negative charges are present in excess of any positive charges that may exist, which gives soil a net negative charge.

Negative surface charges attract positively charged cations and prevent their leaching. These ions are held against leaching by electrostatic positive charges, but are not permanently bound to the surface of soil particles. Positively charged ions are held in a “diffuse cloud” within the water films that are also strongly attracted to the charged soil surfaces. Cations that are retained by soils can thus be replaced, or *exchanged*, by other cations in the soil solution. For example, Ca^{2+} can be exchanged for Al^{3+} and/or K^+ , and vice versa. The higher a soil’s CEC, the more cations it can retain.

There is a direct and positive relationship between the relative abundance of a given cation in solution and the amount of this cation that is retained by the soil CEC. For example, if the predominant cation in the soil solution of a soil is Al^{3+} , Al^{3+} will also be the predominant exchangeable cation. Similarly, when large amounts of Ca^{2+} are added to soil solution by limes dissolving over time, Ca^{2+} will displace Al^{3+} from the exchange complex and allow it to

be neutralized in solution by the alkalinity added with the lime.

The CEC of a soil is expressed in terms of moles of charge per mass of soil. The units used are *cmol⁺/kg* (centimoles of positive charge per kilogram) or *meq/100g* (milliequivalents per 100 grams; 1.0 *cmol⁺/kg* = 1.0 *meq/100g*). Soil CEC is calculated by adding the charge equivalents of K^+ , NH_4^+ , Ca^{2+} , Mg^{2+} , Al^{3+} , Na^+ , and H^+ that are extracted from a soil's exchangeable fraction.

Sources of negative charge in soils

The mineralogy of the clay fraction greatly influences the quantity of negative charges present. One source of negative charge is *isomorphous substitution*, which is the replacement of a Si^{4+} or Al^{3+} cation in the mineral structure with a cation with a lower surface charge. For example, Si^{4+} might be replaced with Al^{3+} , or Al^{3+} with either Mg^{2+} or Fe^{2+} . Clay minerals with a repeating layer structure of two silica sheets sandwiched around an aluminum sheet (2:1 clays, such as vermiculite or smectite), typically have a higher total negative charge than clay minerals with one silica sheet and one aluminum sheet (1:1 clays, such as kaolinite).

Soil pH also has a direct relationship to the quantity of negative charges contributed by organic matter and, to a lesser extent, from mineral surfaces such as iron oxides. As soil pH increases, the quantity of negative charges increases and vice versa. This pH dependent charge is particularly important in highly weathered topsoils where organic matter dominates overall soil charge.

Cation mobility in soils

The negatively charged surfaces of clay particles and organic matter strongly attract cations. However, the retention and release of these cations, which affects their mobility in soil, is dependent on several factors. Two of these factors are the relative retention strength of each cation and the relative amount or mass of each cation present.

For a given cation the relative retention strength by soil is determined by the charge of the ion and the size, or diameter of the ion. In general, the greater the positive charge and the smaller the ionic diameter of a cation, the more tightly the ion is held (i.e., higher retention strength) and the more difficult it is to force the cation to move through the soil profile. For example, Al^{3+} has a positive charge of three and a very small ionic diameter and moves through the soil profile very slowly, while K^+ has a charge of one and a much larger ionic radius, so it leaches much more readily.

If cations are present in equal amounts, the general strength of adsorption that holds cations in the soil is in the following order:

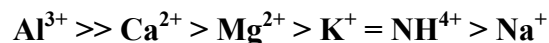

Effect of CEC on soil properties

A soil with a **low CEC value** (1-10 meq/100 g) may have some, or all, of the following characteristics:

- high sand and low clay content
- low organic matter content
- low water-holding capacity
- low soil pH
- will not easily resist changes in pH or other chemical changes
- enhanced leaching potential of plant nutrients such as Ca^{2+} , NH_4^+ , K^+
- low productivity

A soil with a **higher CEC value** (11-50 meq/100g) may have some or all of the following characteristics:

- low sand and higher silt + clay content
 - moderate to high organic matter content
 - high water-holding capacity
 - ability to resist changes in pH or other chemical properties
 - less nutrient losses to leaching than low CEC soils
-

Base saturation

Of the common soil-bound cations, Ca^{2+} , Mg^{2+} , K^+ , and Na^+ are considered to be *basic cations*. The *base saturation* of the soil is defined as the percentage of the soil's CEC (on a charge equivalent basis) that is occupied by these cations. A high base saturation (>50%) enhances Ca, Mg, and K availability and prevents soil pH decline. Low base saturation (<25%) is indicative of a strongly acid soil that may maintain Al^{3+} activity high enough to cause phytotoxicity.

Buffering capacity

The resistance of soils to changes in pH of the soil solution is termed *buffering*. In practical terms, buffering capacity for pH increases with the amount of clay and organic matter. Thus, soils with high clay and organic matter content (high buffer capacity) will require more lime to increase pH than sandy soils with low amounts of organic matter (low, or weak, buffer capacity).

Soil survey

Introduction

The soils of most counties have been mapped by the USDA-NRCS Cooperative Soil Survey Program, and these maps are available in *soil survey reports*. A soil survey report reveals the kinds of soils that exist in the county (or other area) covered by the report at a level of detail that is usually sufficient for agricultural interpretations. The soils are described in terms of their location on the landscape, their profile characteristics, their relationships to one another, their suitability for various uses, and their needs for particular types of management. Each soil survey report contains information about soil morphology, soil genesis, soil conservation, and soil productivity. Soil survey reports are available from county and state USDA-NRCS Cooperative Extension offices and on-line (for certain counties) via http://soils.usda.gov/survey/online_surveys/.

Parts of a soil survey

There are two major sections in a soil survey report. One section contains the soil maps. In most reports, the soil map is printed over an aerial photographic base image. Soil mapping in the past was done at scales ranging from 1:10,000 to 1:50,000, with 1:15,840 being the most common scale used before the 1980's. Current USDA-NRCS mapping is published at 1:24,000 to match United States Geologic Survey (USGS) topographic quadrangle maps.

Each soil area is delineated by an enclosing line on the map. Soil delineation boundaries are drawn wherever there is a significant change in the type of soil. The boundaries may follow contour lines but they also cross contour lines.

The other section of a soil survey report is the narrative portion. Without it, the soil maps would have little meaning. Symbols on each map are keyed to a list of soil mapping units. The nature, properties, and classification and use potentials of all mapping units are described in detail.

Terminology used in soil surveys

- *Soil series* is a basic unit of soil classification, consisting of soils that are essentially alike in all main profile characteristics. Most soil mapping units in modern cooperative soil surveys are named for their dominant component soil series.
- *Soil phase* is a subdivision of a soil series or other unit of classification having characteristics that affect the use and management of the soil but which do not vary enough to merit a separate series. These include variations in slope, erosion, gravel content, and other properties.

- *Soil complexes* and *soil associations* are naturally occurring groupings of two or more soil series with different use and management requirements which occur in a regular pattern across the landscape, but that cannot be separated at the scale of mapping that is used. Soil complexes are used to map two or more series that are commonly intermixed on similar landforms in detailed county soil maps. Soil associations are utilized in more general and less detailed regional soil maps.
 - *Map units* are the actual units which are delineated on the soil map and are usually named for the dominant soil series and slope phase. Map units generally contain more than one soil series. Units are given the name of the dominant soil series if >85% of the area is correlated as a single soil series (or similar soils in terms of use and management). Soil complexes are used to name the map unit if the dissimilar inclusions exceed 15%. Each map unit is given a symbol (numbers or letters) on the soil map, which designates the name of the soil series or complex being mapped and the slope of the soil. More details on how soil mapping units are developed and named can be found at <http://soils.usda.gov/technical/manual/>.
-

Using a soil survey

A user interested in an overall picture of the soils in a county should probably turn first to the soil association section of the soil survey report. The general soil pattern of the county is discussed in this section. A user interested in the soils of a particular farm must first locate that farm on the soil map and determine what soils are present. Index sheets located with the soil maps help the user find the correct section of the map. The map legend gives the soil map unit names for each symbol and assists with the location of descriptive and interpretive material in the report.

Detailed soil descriptions that provide information to those who are primarily interested in the nature and properties of the soils mapped are located in the narrative portion of the soil survey report. The section concerned with the use and management of the soils (*soil interpretations*) is helpful to farmers and others who use the soil or give advice and assistance in its use (e.g., soil conservationists, Cooperative Extension agents). Management needs and estimated yields are included in this section. Newer reports have engineering properties of soils listed in tables that are useful to highway engineers, sanitary engineers, and others who design water storage or drainage projects.

References cited

Soil Survey Division Staff. 1993. Soil survey manual. U.S. Dept. of Agriculture Handbook No. 18. U.S. Govt. Printing Office, Washington, DC.

References for additional information

Note: Although these references are not cited specifically in this chapter, information obtained from them was helpful in writing the chapter.

Brady, N.C., and R.R. Weil. 2001. The nature and properties of soils (13th ed.) Prentice Hall, Upper Saddle River, NJ.

Fanning, D.S., and M.C.B. Fanning. 1989. Soil morphology, genesis, and classification. John Wiley and Sons, New York.

Chapter 4. Basic Soil Fertility

Greg Mullins

Department of Crop and Soil Environmental Sciences, Virginia Tech

David J. Hansen

Department of Plant and Soil Sciences, University of Delaware

Table of Contents

Plant nutrition.....	55
What is an essential element?	55
Categories of essential elements	56
Functions of essential elements in plants.....	57
Nutrient deficiency symptoms	59
Caution regarding visual diagnosis.....	59
Terminology used to describe deficiency symptoms.....	60
Mobility and specific deficiency symptoms	60
Nutrient uptake by crops.....	63
Element uptake.....	63
Soil properties that influence nutrient availability.....	65
Influence of CEC and base saturation on fertilizer management	65
Ion mobility in soils	65
Effect of pH on nutrient availability	66
Liming.....	68
Introduction.....	68
Effect of pH/liming on crop yields	68
Benefits of liming	69
Determining lime requirements	69
Selecting a liming material	70
Frequency of lime applications.....	71
Applying lime	71
Nitrogen	71
The nitrogen cycle.....	71
Nitrogen fixation.....	72
Residual N from legume cover crops.....	73
Forms of soil nitrogen.....	75
Carbon to nitrogen ratios (C:N)	75
Nitrification.....	77
Phosphorus.....	78
The phosphorus cycle	78
Phosphorus availability and mobility.....	79
Phosphorus transport to surface waters.....	82
Potassium	82
The potassium cycle.....	82
Potassium availability and mobility.....	83

Timing and placement of K fertilizer.....	84
Secondary plant nutrients.....	85
Introduction.....	85
Calcium and magnesium.....	85
Sulfur.....	85
Micronutrients.....	87
Introduction.....	87
Determining micronutrient needs	88
Forms in the soil.....	88
Micronutrient soil-plant relationships.....	88
Boron.....	89
Copper.....	89
Iron.....	90
Manganese	90
Molybdenum.....	91
Zinc	91
Chlorine.....	92
References cited.....	93

Plant nutrition

What is an essential element?

An *essential mineral element* is one that is required for normal plant growth and reproduction. With the exception of carbon (C) and oxygen (O), which are supplied from the atmosphere, the essential elements are obtained from the soil. The amount of each element required by the plant varies; however, all essential elements are equally important in terms of plant physiological processes and plant growth.

The exact number of elements that should be considered “essential” to plant growth is a matter of some debate. For example, cobalt, which is required for N fixation in legumes, is not considered to be an essential element by some researchers. Table 4.1 lists 18 elements that are considered essential by many scientists. Other elements that are sometimes listed as essential are sodium (Na), silicon (Si), and vanadium (V).

Table 4.1. Eighteen essential elements for plant growth, and the chemical forms most commonly taken up by plants.

Element	Symbol	Form Absorbed by Plants
Carbon	C	CO ₂
Hydrogen	H	H ⁺ , OH ⁻ , H ₂ O
Oxygen	O	O ₂
Nitrogen	N	NH ₄ ⁺ , NO ₃ ⁻
Phosphorus	P	HPO ₄ ²⁻ , H ₂ PO ₄ ⁻
Potassium	K	K ⁺
Calcium	Ca	Ca ²⁺
Magnesium	Mg	Mg ²⁺
Sulfur	S	SO ₄ ²⁻
Iron	Fe	Fe ²⁺ , Fe ³⁺
Manganese	Mn	Mn ²⁺ , Mn ⁴⁺
Boron	B	H ₃ BO ₃ , BO ₃ ⁻ , B ₄ O ₇ ²⁻
Zinc	Zn	Zn ²⁺
Copper	Cu	Cu ²⁺
Molybdenum	Mo	MoO ₄ ²⁻
Chlorine	Cl	Cl ⁻
Cobalt	Co	Co ²⁺
Nickel	Ni	Ni ²⁺

Categories of essential elements

Essential elements can be grouped into four categories based on their origin or the relative amount a plant needs in order to develop properly (Table 4.2).

Non-mineral essential elements are derived from the air and water. *Primary* essential elements are most often applied in commercial fertilizers or in manures. *Secondary* elements are normally applied as soil amendments or are components of fertilizers that carry primary nutrients. Non-mineral, primary and secondary elements are also referred to as *macronutrients* since they are required in relatively large amounts by plants.

Micronutrients are required in very small, or *trace*, amounts by plants. Although micronutrients are required by plants in very small quantities, they are equally essential to plant growth.

Table 4.2. Essential elements, their relative uptake, and sources where they are obtained by plants.

MACRONUTRIENTS			MICRONUTRIENTS
<i>Non-Mineral</i>	<i>Primary</i>	<i>Secondary</i>	
<i>Mostly from air and water</i>	<i>Mostly from soils</i>	<i>Mostly from soils</i>	<i>Mostly from soils</i>
Carbon	Nitrogen	Calcium	Iron
Hydrogen	Phosphorus	Magnesium	Manganese
Oxygen	Potassium	Sulfur	Boron
			Zinc
			Copper
			Molybdenum
			Chlorine
			Cobalt
			Nickel

Functions of essential elements in plants

Essential Element	Function In Plant
Carbon, Hydrogen, & Oxygen	<ul style="list-style-type: none"> • Directly involved in photosynthesis, which accounts for most of plant growth: $6 \text{ CO}_2 + 12 \text{ H}_2\text{O} \rightarrow 6 \text{ O}_2 + 6 (\text{CH}_2\text{O}) + 6 \text{ H}_2\text{O}$
Nitrogen	<ul style="list-style-type: none"> • Found in chlorophyll, nucleic acids, and amino acids. • Component of protein and enzymes, which control almost all biological processes.
Phosphorus	<ul style="list-style-type: none"> • Typically concentrated in the seeds of many plants as phytin. • Important for plant development including: <ul style="list-style-type: none"> – development of a healthy root system – normal seed development – uniform crop maturation – photosynthesis, respiration, cell division, and other processes – Essential component of Adenosine Triphosphate (ATP), which is directly responsible for energy transfer reactions in the plant. • Essential component of DNA and RNA, and phospholipids, which play critical roles in cell membranes.
Potassium	<ul style="list-style-type: none"> • Found in ionic form in the cell, rather than incorporated in structure of organic compounds. • Responsible for: <ul style="list-style-type: none"> – regulation of water usage in plants – disease resistance – stem strength • Involved in: <ul style="list-style-type: none"> – photosynthesis – drought tolerance – improved winter-hardiness – protein synthesis • Linked to improvement of overall crop quality, including handling and storage quality.
Calcium	<ul style="list-style-type: none"> • Essential for cell elongation and division. • Specifically required for: <ul style="list-style-type: none"> – root and leaf development – function and cell membranes – formation of cell wall compounds • Involved in the activation of several plant enzymes.

Essential Element	Function In Plant
Magnesium	<ul style="list-style-type: none"> • Primary component of chlorophyll and is therefore actively involved in photosynthesis. • Structural component of ribosomes, which are required for protein synthesis. • Involved in phosphate metabolism, respiration, and the activation of several enzyme systems.
Sulfur	<ul style="list-style-type: none"> • Required for the synthesis of the sulfur-containing amino acids <i>cystine</i>, <i>cysteine</i>, and <i>methionine</i>, which are essential for protein formation. • Involved with: <ul style="list-style-type: none"> – development of enzymes and vitamins – promotion of nodulation for N fixation by legumes – seed production chlorophyll formation – formation of several organic compounds that give characteristic odors to garlic, mustard, and onion.
Boron	<ul style="list-style-type: none"> • Essential for: <ul style="list-style-type: none"> – germination of pollen grains and growth of pollen tubes – seed and cell wall formation – development and growth of new cells in meristematic tissue • Forms sugar/borate complexes associated with the translocation of sugars, starches, N, and P. • Important in protein synthesis.
Copper	<ul style="list-style-type: none"> • Necessary for chlorophyll formation. • Catalyzes several enzymes.
Iron	<ul style="list-style-type: none"> • Serves as a catalyst in chlorophyll synthesis. • Involved in many oxidation-reduction reactions during respiration and photosynthesis.
Manganese	<ul style="list-style-type: none"> • Functions primarily as a part of the enzyme systems in plants. • Serves as a catalyst in chlorophyll synthesis along with iron. • Activates several important metabolic reactions (enzymes). • Plays a direct role in photosynthesis.
Zinc	<ul style="list-style-type: none"> • Aids in the synthesis of plant growth compounds and enzyme systems. • Essential for promoting certain metabolic/enzymatic reactions. • Necessary for the production of chlorophyll, carbohydrates, and growth hormones.

Essential Element	Function In Plant
Molybdenum	<ul style="list-style-type: none"> • Required for the synthesis and activity of nitrate reductase; the enzyme system that reduces NO_3^- to NH_4^+ in the plant. • Essential in the process of symbiotic N fixation by <i>Rhizobia</i> bacteria in legume root nodules.
Chlorine	<ul style="list-style-type: none"> • Involved in: <ul style="list-style-type: none"> – energy reactions in the plant – breakdown of water – regulation of stomata guard cells – maintenance of turgor and rate of water loss – plant response to moisture stress and resistance to some diseases – Activates several enzyme systems. • Serves as a counter ion in the transport of several cations in the plant.
Cobalt	<ul style="list-style-type: none"> • Essential in the process of symbiotic N fixation by <i>Rhizobia</i> bacteria in legume root nodules. • Has not been proven to be essential for the growth of all higher plants.
Nickel	<ul style="list-style-type: none"> • Component of the urease enzyme. • Essential for plants supplied with urea and for those in which ureides are important in N metabolism.

Nutrient deficiency symptoms

Caution regarding visual diagnosis

Visual diagnosis of plant deficiencies can be very risky. There may be more than one deficiency symptom expressed, which can make diagnosis difficult. **Both soil and tissue samples should be collected, analyzed, and interpreted before any recommendations are made concerning application of fertilizer.**

Terminology used to describe deficiency symptoms

Term	Definition
<i>Chlorosis</i>	Yellowing or lighter shade of green
<i>Necrosis</i>	Browning or dying of plant tissue
<i>Interveinal</i>	Between the leaf veins
<i>Meristem</i>	The growing point of a plant
<i>Internode</i>	Distance of the stem between the leaves
<i>Mobile</i>	A mobile element is one that is able to <i>translocate</i> , or move, from one part of the plant to another depending on its need. Mobile elements generally move from older (lower) plant parts to the plant's site of most active growth (<i>meristem</i>).

Mobility and specific deficiency symptoms

Essential Element	Mobility	Deficiency Symptoms and Occurrence
Nitrogen	Mobile within plants: lower leaves show chlorosis first.	<ul style="list-style-type: none"> • Stunted, slow growing, chlorotic plants. • Reduced yield. • Plants more susceptible to weather stress and disease. • Some crops may mature earlier.
Phosphorus	Mobile within plants: lower leaves show deficiency first.	<ul style="list-style-type: none"> • Over-all stunted plant and a poorly developed root system. • Can cause purple or reddish color associated with the accumulation of sugars. • Difficult to detect in field.
Potassium	Mobile within plants: lower leaves show deficiency first.	<ul style="list-style-type: none"> • Commonly causes scorching or firing along leaf margins. • Deficient plants grow slowly, have poorly-developed root systems, weak stalks; lodging is common. • Seed and fruit are small and shriveled. • Plants possess low resistance to disease. • Deficiencies most common on acid sandy soils and soils that have received large applications of Ca and/or Mg.

Essential Element	Mobility	Deficiency Symptoms and Occurrence
Calcium	Not mobile within plants: upper leaves and the growing point show deficiency symptoms first.	<ul style="list-style-type: none"> • Poor root growth: Ca deficient roots often turn black and rot. • Failure of terminal buds of shoots and apical tips of roots to develop, causing plant growth to cease. • Most often occurs on very acid soils where Ca levels are low. • Other deficiency effects such as high acidity usually limit growth before Ca deficiency apparent.
Magnesium	Mobile within plants: lower leaves show deficiency first.	<ul style="list-style-type: none"> • Leaves show a yellowish, bronze or reddish color while leaf veins remain green.
Sulfur	Somewhat mobile within plants but upper leaves tend to show deficiency first.	<ul style="list-style-type: none"> • Chlorosis of the longer leaves. • If deficiency is severe, entire plant can be chlorotic and stunted. • Symptoms resemble those of N deficiency; can lead to incorrect diagnoses.
Boron	Not mobile within plants: upper leaves and the growing point show deficiency symptoms first.	<ul style="list-style-type: none"> • Reduced leaf size and deformation of new leaves. • Interveinal chlorosis if deficiency is severe. • May cause distorted branches and stems. • Related to flower and or fruit abortion, poor grain fill, and stunted growth. • May occur on very acid, sandy-textured soils or alkaline soils.
Copper	Not mobile within plants: upper leaves and the growing point show deficiency symptoms first.	<ul style="list-style-type: none"> • Reduced leaf size. • Uniformly pale yellow leaves. • Leaves may lack turgor and may develop a bluish-green cast, become chlorotic and curl. • Flower production fails to take place. • Organic soils are most likely to be Cu deficient.

Essential Element	Mobility	Deficiency Symptoms and Occurrence
Iron	Not mobile within plants: upper leaves show deficiency symptoms first.	<ul style="list-style-type: none"> • Interveinal chlorosis that progresses over the entire leaf. With severe deficiencies, leaves turn entirely white. • Factors contributing to Fe deficiency include imbalance with other metals, excessive soil P levels, high soil pH, wet, and cold soils.
Manganese	Not mobile within plants: upper leaves show deficiency symptoms first.	<ul style="list-style-type: none"> • Interveinal chlorosis. • Appearance of brownish-black specks. • Occurs most often on high organic matter soils and soils with neutral to alkaline pH with low native Mn content.
Zinc	Not mobile within plants: upper leaves and the growing point show deficiency symptoms first.	<ul style="list-style-type: none"> • Shortened internodes between new leaves. • Death of meristematic tissue. • Deformed new leaves. • Interveinal chlorosis. • Occurs most often on alkaline (high pH) soils or soils with high available P levels.
Molybdenum	Not mobile within plants: upper leaves show deficiency symptoms first.	<ul style="list-style-type: none"> • Interveinal chlorosis. • Wilting. • Marginal necrosis of upper leaves. • Occurs principally on very acid soils, since Mo becomes less available with low pH.
Chlorine	Mobile within plant, but deficiency symptoms usually appear on the upper leaves first.	<ul style="list-style-type: none"> • Chlorosis in upper leaves. • Overall wilting of the plants. • Deficiencies may occur in well drained soils under high rainfall conditions.
Cobalt	Used by symbiotic N-fixing bacteria in root nodules of legumes and other plants.	<ul style="list-style-type: none"> • Causes N deficiency: chlorotic leaves and stunted plants. • Occurs in areas with soils deficient in native Co.

Essential Element	Mobility	Deficiency Symptoms and Occurrence
Nickel	Mobile within plants.	<ul style="list-style-type: none"> Symptoms and occurrence are not well documented but may include chlorosis and necrosis in young leaves and failure to produce viable seeds.

Note: Information given above on nutrient mobility and deficiency symptoms is condensed. For more information, or for information on deficiency symptoms for a specific crop, please see Bennett, 1993; Horst, 1995; Jones, 1998; PPI, 2003, or your state's Cooperative Extension Service publications.

Nutrient uptake by crops

Element uptake The amount of nine different elements taken up by selected crops is shown in Tables 4.3a through 4.3c.

Table 4.3a. Nutrient removal by selected hay crops.

Crop	Yield	N	P	K	Ca	Mg	S	Cu	Mn	Zn
		----- pounds per acre -----								
Alfalfa	6 tons	350	40	300	160	40	44	0.10	0.64	0.62
Bluegrass	2 tons	60	12	55	16	7	5	0.02	0.30	0.08
Coastal Bermuda-grass	8 tons	400	45	310	48	32	32	0.02	0.64	0.48
Fescue	3.5 tons	135	18	160	--	13	20	--	--	--
Orchard Grass	6 tons	300	50	320	--	25	35	--	--	--
Red Clover	2.5 tons	100	13	90	69	17	7	0.04	0.54	0.36
Soybean	2 tons	90	12	40	40	18	10	0.04	0.46	0.15
Timothy	4 tons	150	24	190	18	6	5	0.03	0.31	0.20

Table 4.3b. Nutrient removal by selected field crops.

Crop	Yield	N	P	K	Ca	Mg	S	Cu	Mn	Zn
		----- pounds per acre -----								
Barley (grain)	60 bu	65	14	24	2	6	8	0.04	0.03	0.08
Barley (straw)	2 tons	30	10	80	8	2	4	0.01	0.32	0.05
Corn (grain)	200 bu	150	40	40	6	18	15	0.08	0.10	0.18
Corn (stover)	6 tons	110	12	160	16	36	16	0.05	1.50	0.30
Cotton (seed+lint)	1.3 tons	63	25	31	4	7	5	0.18	0.33	0.96
Cotton (stalk+leaf)	1.5 tons	57	16	72	56	16	15	0.05	0.06	0.75
Oats (grain)	80 bu	60	10	15	2	4	6	0.03	0.12	0.05
Oats (straw)	2 tons	35	8	90	8	12	9	0.03	--	0.29
Peanuts (nuts)	2 tons	140	22	35	6	5	10	0.04	0.30	0.25
Peanuts (vines)	2.5 tons	100	17	150	88	20	11	0.12	0.15	--
Rye (grain)	30 bu	35	10	10	2	3	7	0.02	0.22	0.03
Rye (straw)	1.5 tons	15	8	25	8	2	3	0.01	0.14	0.07
Soybean (grain)	50 bu	188	41	74	19	10	23	0.05	0.06	0.05
Soybean (stover)	3 tons	89	16	74	30	9	12	--	--	--
Wheat (grain)	60 bu	70	20	25	2	10	4	0.04	0.10	0.16
Wheat (straw)	2.5 tons	45	5	65	8	12	15	0.01	0.16	0.05
Tobacco (burley)	2 tons	145	14	150	--	18	24	--	--	--
Tobacco (flue cured)	1.5 tons	85	15	155	75	15	12	0.03	0.55	0.07

Table 4.3c. Nutrient removal by selected fruit and vegetable crops.

Crop	Yield	N	P	K	Ca	Mg	S	Cu	Mn	Zn
		----- pounds per acre -----								
Apples	500 bu	30	10	45	8	5	10	0.03	0.03	0.03
Cabbage	20 tons	130	35	130	20	8	44	0.04	0.10	0.08
Peaches	600 bu	35	20	65	4	8	2	--	--	0.01
Potato (sweet)	300 bu	40	18	96	4	4	6	0.02	0.06	0.03
Potato (white)	15 tons	90	48	158	5	7	7	0.06	0.14	0.08
Snap Bean	4 tons	138	33	163	--	17	--	--	--	--
Spinach	5 tons	50	15	30	12	5	4	0.02	0.10	0.10
Tomatoes (fruit)	20 tons	120	40	160	7	11	14	0.07	0.13	0.16

Soil properties that influence nutrient availability

Influence of CEC and base saturation on fertilizer management

A soil's CEC should be considered when determining the appropriate rates and timing of nutrient applications in a fertilizer program. In general, smaller amounts of fertilizer, applied more often, are needed in low CEC soils to prevent leaching losses, while larger amounts may be applied less frequently in high CEC soils. For example, it may not be wise to apply K on very sandy soils with low CEC in the fall to serve the next spring's crops, especially in areas where fall and winter rainfall is high. In comparison, on clayey soils with high CEC, adequate K can be applied in the fall for one or more future crops.

In the past, the concept of base saturation was used to develop fertilizer programs. This school of thought held that certain nutrient ratios, or "balances," are needed for optimum crop nutrition. Most crops grow best at a base saturation of 80% or more; however, research has shown that saturation ranges for specific cations (esp., K, Mg, and Ca) have little or no utility in the majority of agricultural soils. Under field conditions, relative amounts of nutrients can vary widely with no detrimental effects, as long as individual nutrients are present in sufficient levels in the soil to support optimum plant growth.

Ion mobility in soils

Anions (negatively charged ions) usually leach more readily than cations because they are not attracted to the predominantly negative charge of soil colloids. For example, NO_3^- , due to its negative charge and relatively large ionic radius, is not readily retained in the soil and is easily lost from soils by leaching.

An exception to this behavior is phosphorus anions (HPO_4^{2-} , H_2PO_4^-). These anionic forms do not easily leach through the soil profile because of their specific complexing reactions with soil components. Surface applications of inorganic and organic sources of P without incorporation will result in the accumulation of P near the soil surface. Estimates of vertical P movement in most agricultural soils are on the order of 0.5 to 1 inch per year with an average rainfall of 36 inches, with greater movement in coarse-textured than fine-textured soils. Since P can accumulate near the soil surface, losses of P from agricultural systems are associated with a combination of residual soil P levels and soil erosion.

**Effect of pH
on nutrient
availability**

Many soil elements change form as a result of chemical reactions in the soil. Plants may or may not be able to use elements in some of these forms. Because pH influences the soil concentration and, thus, the availability of plant nutrients, it is responsible for the solubility of many nutrient elements. Figure 4.1 illustrates the relationship between soil pH and the relative plant availability of nutrients.

- **K, Ca, and Mg:** These nutrients are most present in soils with pH levels greater than 6.0. They are generally not as available for plant uptake in acid soils since they may have been partially leached out of the soil profile.
- **P:** Phosphorus solubility and plant availability are controlled by complex soil chemical reactions, which are often pH-dependent. Plant availability of P is generally greatest in the pH range of 5.5 to 6.8. When soil pH falls below 5.8, P reacts with Fe and Al to produce insoluble Fe and Al phosphates that are not readily available for plant uptake. At high pH values, P reacts with Ca to form Ca phosphates that are relatively insoluble and have low availability to plants.
- **Micronutrients:** In general, most micronutrients are more available in acid than alkaline soils. As pH increases, micronutrient availability decreases, and the potential for deficiencies increase. An exception to this trend is Mo, which becomes less available as soil pH decreases. In addition, B becomes less available when the pH is <5.0 and again when the pH exceeds 7.0.
- **Al, Fe, and Mn Toxicity:** At pH values less than 5.0, Al, Fe, and Mn may be soluble in sufficient quantities to be toxic to the growth of some plants. Aluminum toxicity limits plant growth in most strongly acid soils. Aluminum begins to solubilize from silicate clays and aluminum hydroxides below a pH of approximately 5.3, which increases the activity of exchangeable Al^{3+} . High concentrations of exchangeable Al are toxic and detrimental to plant root development.
- **Soil Organisms:** Soil organisms grow best in near-neutral soil. In general,

acid soil inhibits the growth of most organisms, including many bacteria and earthworms. Thus, acid soil slows many important activities carried on by soil microbes, including nitrogen fixation, nitrification, and organic matter decay. *Rhizobia* bacteria, for instance, thrive at near-neutral pH and are sensitive to solubilized Al.

Figure 4.1. Relationship between soil pH and nutrient availability.

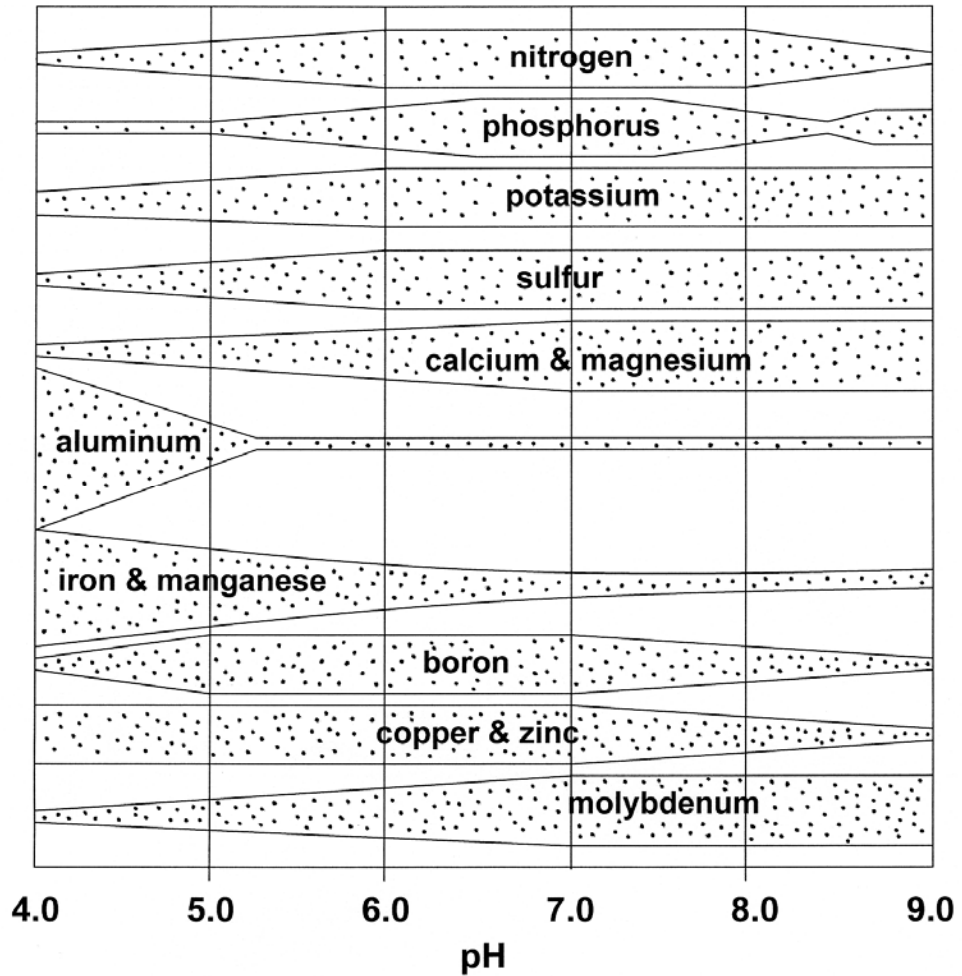

Liming

Introduction

Acid soil limits crop yields on many farms in the Mid-Atlantic region. With only a few exceptions, the climate in this region causes non-limed soils to be moderately to strongly acidic. Acidification is a natural process that occurs continuously in soils throughout the Mid-Atlantic region. It is caused by the following factors:

- The **breakdown of organic matter** can cause acidification of the soil as amino acids are converted into acetic acid, hydrogen gas, dinitrogen gas, and carbon dioxide by the reaction:



- The **movement of acidic water from rainfall** through soils slowly leaches basic essential elements such as Ca, Mg, and K below the plant root zone and increases the concentration of exchangeable soil Al. Soluble Al^{3+} reacts with water to form H^+ ($\text{Al}^{3+} + \text{H}_2\text{O} \leftrightarrow \text{Al}(\text{OH})^{2+} + \text{H}^+$), which makes the soil acid.
- **Soil erosion** removes exchangeable cations adsorbed to clay particles.
- Hydrogen is released into the soil by plants' root systems as a result of respiration and ion uptake processes during **plant growth**.
- **Nitrogen fertilization** speeds up the rate at which acidity develops, primarily through the acidity generated by nitrification:



- The **harvesting of crops** removes basic cations.
-

Effect of pH/liming on crop yields

Liming is a critical management practice for maintaining soil pH at optimal levels for growth of plants. Over-liming can induce micronutrient deficiencies by increasing pH above the optimum range.

Most crops grow well in the pH range 5.8 to 6.5. Legumes generally grow better in soils limed to pH values of 6.2 to 6.8. Plants such as blueberries, mountain laurel, and rhododendron grow best in strongly acid (pH < 5.2) soils. Most crops will grow well on organic soils (>20% organic matter), even if the pH is in the range of 5.0 to 5.5, because much of the acidity such soils is derived from non-toxic organic matter functional groups rather than toxic Al.

Benefits of liming

- Liming reduces the solubility and potential toxicity of Al and Mn.
 - Liming supplies the essential elements Ca and/or Mg. Both are generally low in very acid soils.
 - Liming increases the availability of several essential nutrients.
 - Liming stimulates microbial activity (i.e., nitrification) in the soil.
 - Liming improves symbiotic nitrogen fixation by legumes.
 - Liming improves the physical conditions of the soil.
 - Maintaining a proper soil pH helps to improve the efficiency of some herbicides.
-

Determining lime requirements

Soil pH is an excellent indicator of soil acidity; however, it does not indicate how much total acidity is present, and it cannot be used to determine a soil's lime requirement when used alone.

The *lime requirement* for a soil is the amount of agricultural limestone needed to achieve a desired pH range for the cropping system used. Soil pH determines only active acidity (the amount of H^+ in the soil solution at that particular time), while the lime requirement determines the amount of exchangeable, or reserve acidity, held by soil clay and organic matter (Figure 4.2).

Most laboratories use soil pH in combination with “buffered” solutions to extract and measure the amount of reserve acidity, or *buffering capacity* (see Chapter 3) in a soil. The measured amount of exchangeable/reserve acidity is then used to determine the proper amount of lime needed to bring about the desired increase in soil pH. **The rate of agricultural limestone applied to any agricultural field should be based on soil test recommendations.**

Figure 4.2. Relationship between residual, exchangeable, and active acidity in soils.

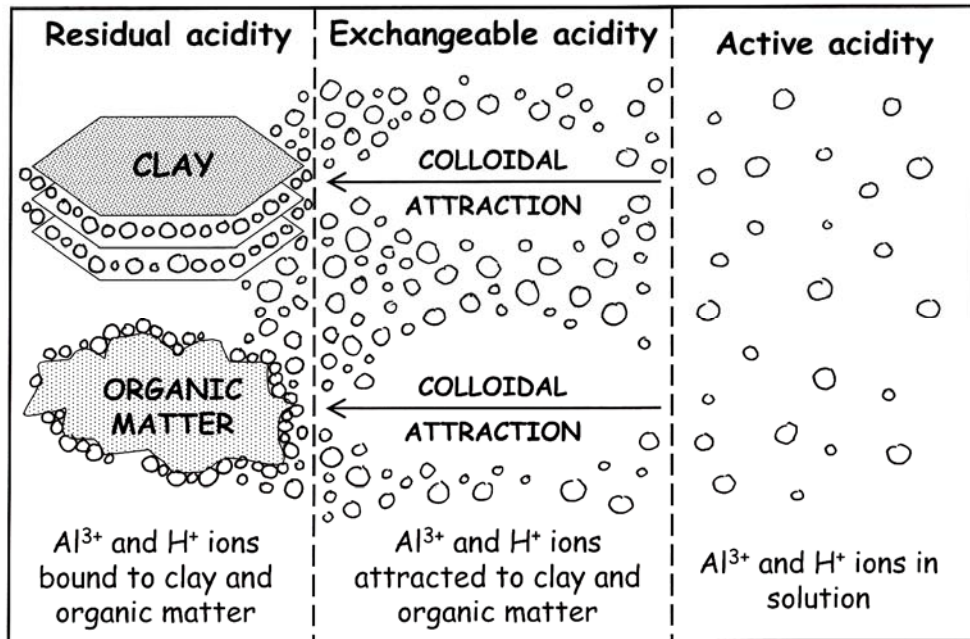

Selecting a liming material

Factors to consider in selecting a liming material include:

- **Calcium carbonate equivalence (CCE):** CCE is a measure of the liming capability of a material relative to pure calcium carbonate expressed as a percentage. A liming material with a CCE of 50 has 50% of the liming capability of calcium carbonate.
- **Length of time between application of lime and planting of crop:** The choice between a slower acting and a quick-acting liming material is often determined by the time between application of lime and crop planting.
- **Crop value:** The value of the crop, especially those crops that are acid-sensitive or have a critical pH requirement, should be considered in determining what lime source to use. It may be desirable to use pulverized, hydrated (Ca(OH)₂), or burned (CaO) lime, which will neutralize soil acidity quickly, when growing an acid-sensitive crop in strongly acid soils. Although the cost per acre will be greater, improved crop performance should result in higher net income. Aglime has its maximum effect in a period of one to three years, while suspension lime, burned lime, and hydrated lime have their maximum effect in three to six months.
- **Need for magnesium:** Calcitic lime should be used in soils with high magnesium levels, while dolomitic limes should be used on soils low in magnesium. Use soil test data to determine which type of lime to use.

Frequency of lime applications

Intensive cropping systems result in more frequent need for liming as Ca and Mg are depleted with crop removal and soil becomes acidified due to higher ammonium-N applications. A soil test every two or three years will reveal whether or not lime is needed. Sandy soils generally require less lime at any one application than silt loam or clay soils to decrease soil acidity by a given amount. Sandy soils, however, usually need to be limed more frequently because their buffering capacity is low.

Applying lime

Lime moves slowly in soil from the point of application, and lime particles dissolve more slowly as acidity is reduced. In conventionally tilled systems, lime should be mixed to tillage depth in order to effectively neutralize soil acidity in the primary root zone. On moderately acid soils (pH 5.2 - 5.7), a single application of lime made either before or after tillage will usually give good results. For strongly acid soils (pH 5.0 and lower) that have very high lime requirements, it may be desirable to apply one-half of the lime before tillage and the remaining half after tillage. For large areas that have high lime requirements (3-4 tons/acre), it may be best to apply half of the required lime in a first year application and the remainder in the second year.

Agricultural limestone can be applied anytime between the harvest of a crop and the planting of the next. Lime is usually broadcast on the soil surface before tillage operations and incorporated into the soil. In conservation tillage systems and on pastures and hay fields, surface applications can be made whenever soil conditions allow spreaders to enter the fields. Research with no-tillage corn and forages has shown that surface applied lime has been effective in reducing soil acidity in the surface two to four inches of soil.

Nitrogen

The nitrogen cycle

Nitrogen is subject to more transformations than any other essential element. These cumulative gains, losses, and changes are collectively termed the *nitrogen cycle* (Figure 4.3). The ultimate source of N is N₂ gas, which comprises approximately 78% of the earth's atmosphere. Inert N₂ gas, however, is unavailable to plants and must be transformed by biological or industrial processes into forms which are plant-available. As a result, modern agriculture is heavily dependent on commercial N fertilizer. Some of the more important components of the N cycle are discussed below.

Figure 4.3. The nitrogen cycle (modified from the Potash & Phosphate Institute web site at www.ppi-ppic.org).

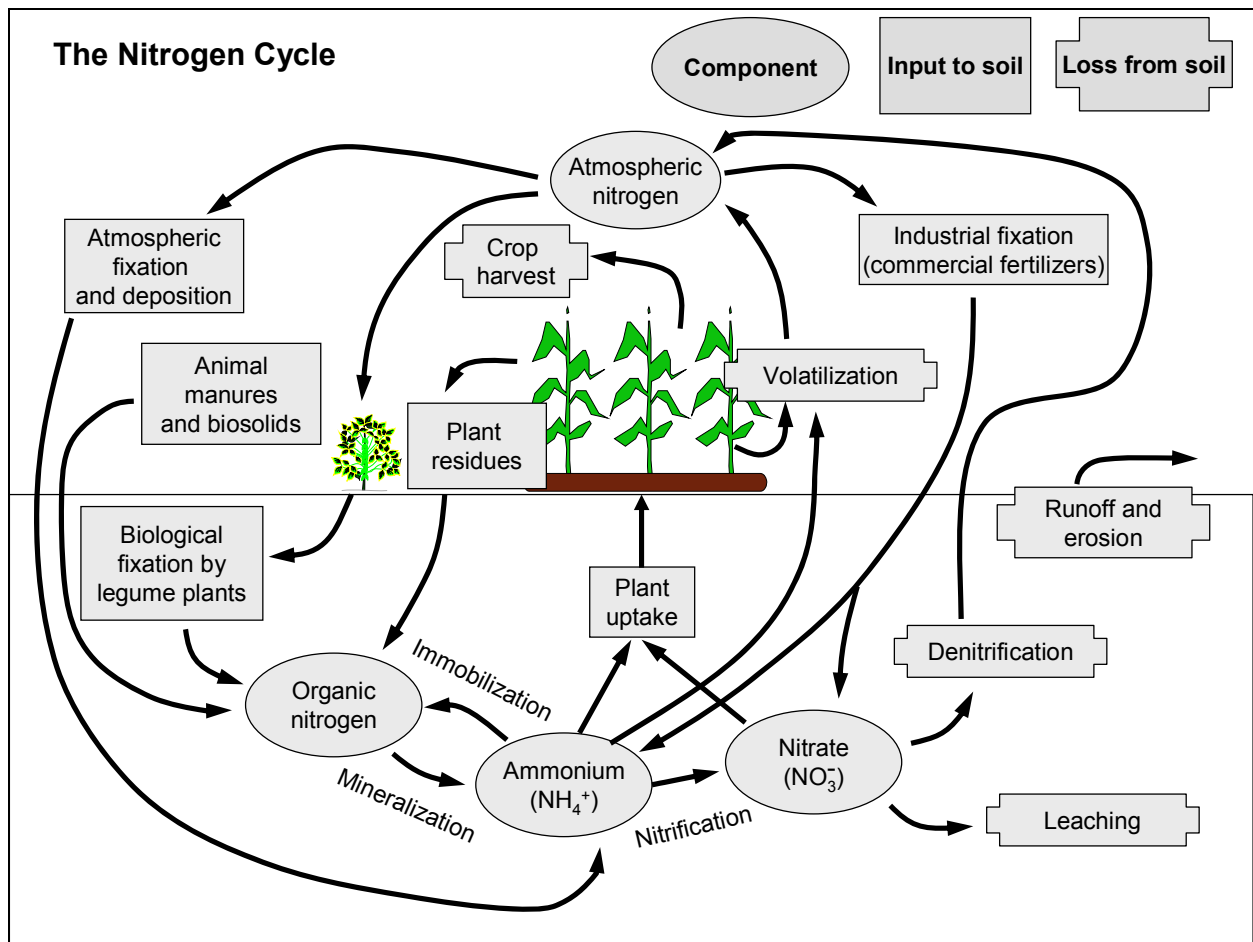

Nitrogen fixation

Nitrogen fixation is the process whereby inert N₂ gas in the atmosphere is transformed into forms that are plant-available, including NH₄⁺ or NO₃⁻. Fixation can take place by biological or by non-biological processes.

• **Biological N fixation** processes include:

– **Symbiotic N fixation:** This process is mediated by bacteria with the ability to convert atmospheric N₂ to plant-available N while growing in association with a host plant. Symbiotic *Rhizobium* bacteria fix N₂ in nodules present on the roots of legumes. Through this relationship, the bacteria make N₂ from the atmosphere available to the legume as it is excreted from the nodules into the soil. In the Mid-Atlantic region, the quantity of N fixed by most leguminous crops is probably less than 150 lbs/acre/year.

– **Non-symbiotic N fixation:** This is a N₂ fixation process that is performed

by free-living bacteria and blue-green algae in the soil. The amount of N₂ fixed by these organisms is much lower than that fixed by symbiotic N₂ fixation.

- **Non-biological N fixation** processes include:
 - **Atmospheric additions:** Small amounts of N in the order of 5-15 lbs/acre/year can be added to the soil in the form of rain or snowfall. This includes N that has been fixed by the electrical discharge of lightning in the atmosphere and industrial pollution.
 - **Synthetic or industrial processes of N fixation:** The industrial fixation of N is the most important source of N as a plant nutrient. The production of N by industrial processes is based on the Haber-Bosch process where hydrogen (H₂) and N₂ gases react to form NH₃:

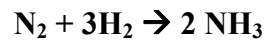

Hydrogen gas for this process is obtained from natural gas and N₂ comes directly from the atmosphere. The NH₃ produced can be used directly as a fertilizer (anhydrous NH₃) or as the raw material for other N fertilizer products, including ammonium phosphates, urea, and ammonium nitrate.

**Residual N
from legume
cover crops**

Nitrogen contained in the residues from a previous legume crop is an important source of N and should be considered when developing an N fertilization program. The amounts of residual N left in the soil from previous legume crops are summarized in Table 4.4. Accounting for residual N from legumes can reduce both N fertilizer costs and the risk of NO₃⁻ losses by leaching.

Table 4.4. Residual nitrogen credits provided by legumes, by Mid-Atlantic state. Sources: Pennsylvania: Pennsylvania Agronomy Guide, 2005-2006, 2005; Maryland: Maryland Nutrient Management Manual, 2005; Delaware: Sims and Gartley, 1996; Virginia/West Virginia: Virginia Division of Conservation and Recreation, 2005.

Legume	Criteria	-----State-----			
		Pennsylvania	Maryland	Delaware	Virginia/ West Virginia
		----- nitrogen credit, lbs/acre -----			
Alfalfa	First Year After Legume	---	100-150 [‡]	90	---
	> 50% stand	80-120 [†]	---	---	90
	25-49% stand	60-80 [†]	---	---	70
	< 25% stand	40	---	---	50
Red clover & trefoil	First Year After Legume		40	60	
	> 50% Stand	60-90 [†]	---	---	80 ^{††}
	25-49% stand	50-60 [†]	---	---	60 ^{††}
	< 25% stand	40	---	---	40 ^{††}
Ladino clover		---	60	---	---
Crimson clover		---	50-100 [¶]	---	---
Hairy vetch		---	75-150 [¶]	---	50-100 ^{‡‡}
Austrian winter peas		---	75-150 [¶]	---	---
Lespedeza		---	20	---	---
Peanuts		---	---	---	45
Soybeans	First Year After Grain	1 lb N/bu soybeans	15-20 [§]	0.5 lb/bu soybeans	0.5 lb/bu of soybeans or 20 lbs if yield is unknown

[†] Actual rate depends on soil productivity group.

[‡] Depends on stand; if stand is good (> 4 plants per square foot), credit 150 lbs.; if stand is fair (1.5 to 4 plants per square foot), credit 125 lbs.; if stand is poor (< 1.5 plants per square foot), credit 100 lbs.

[¶] Depends on planting date (and biomass production), kill date and subsequent tillage.

[§] A minimum of 15 lbs. and may be as much as 1 lb per bushel of soybeans, up to a maximum of 40 lbs.

^{††} Applies to red clover only.

^{‡‡} Depends on stand: if stand is good (80-100%), credit 100 lbs.; if stand is fair (50-79%), credit 75 lbs.; if stand is poor (<50%), credit 50 lbs.

Forms of soil nitrogen

Soil N occurs in both inorganic and organic forms. Most of the total N in surface soils is present as organic N.

• **Inorganic forms of soil N** include:

- ammonium (NH_4^+)
- nitrite (NO_2^-)
- nitrate (NO_3^-)
- nitrous oxide ($\text{N}_2\text{O}_{\text{gas}}$)
- nitric oxide (NO_{gas})
- elemental N (N_2_{gas})

NH_4^+ , NO_2^- , and NO_3^- are the most important plant nutrient forms of N and usually comprise 2 to 5% of total soil N.

• **Organic soil N** occurs in the form of amino acids, amino sugars, and other complex N compounds.

N *mineralization* (Figure 4.4) is the conversion of organic N to NH_4^+ . This is an important process in the N cycle since it results in the liberation of plant-available inorganic N forms.

N *immobilization* is the conversion of inorganic plant available N (NH_4^+ or NO_3^-) by soil microorganisms to organic N forms (amino acids and proteins). This conversion is the reverse of mineralization, and these immobilized forms of N are not readily available for plant uptake.

Figure 4.4. Forms of soil nitrogen

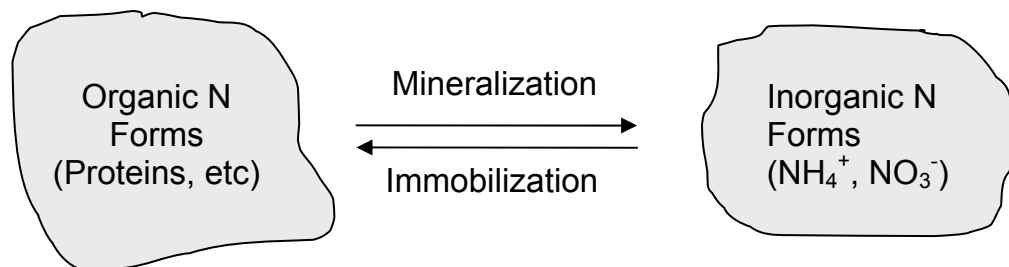

Carbon to nitrogen ratios (C:N)

Immobilization and mineralization are ongoing processes in the soil and are generally in balance with one another. This balance can be disrupted by the incorporation of organic residues that have high carbon to nitrogen ratios (C:N). The ratio of %C to %N, or the C:N ratio, defines the relative quantities of these elements in residues and living tissues. Whether N is mineralized or immobilized depends on the C:N ratio of the organic matter being decomposed by soil microorganisms:

- **Wide C:N ratios of > 30:1:** Immobilization of soil N will be favored. Residues with wide C:N ratios include hay, straw pine needles, cornstalks, dry leaves, and sawdust.
- **C:N ratios of 20:1 to 30:1:** Immobilization and mineralization will be nearly equal.
- **Narrow C:N ratios of < 20:1:** Favor rapid mineralization of N. Residues with narrow C:N ratios include alfalfa, clover, manures, biosolids, and immature grasses.

The decomposition of a crop residue with a high C:N ratio is illustrated in Figure 4.5. Shortly after incorporation, high C:N ratio residues are attacked and used as an energy source by soil microorganisms. As these organisms decompose the material, there is competition for the limited supply of available N since the residue does not provide adequate N to form proteins in the decaying organisms. During this process, available soil N is decreased and the C in the residues is liberated as CO₂ gas. As decomposition proceeds, the residue's C:N ratio narrows and the energy supply is nearly exhausted. At this point, some of the microbial populations will die and the mineralization of N in these decaying organisms will result in the liberation of plant-available N. The timing of this process will depend on such factors as soil temperature, soil moisture, soil chemical properties, fertility status, and the amount of residues added. The process can be accelerated by applying N fertilizer sources at the time of application of the residue.

Figure 4.5. Nitrogen immobilization and mineralization after material with a high C:N ratio is added to soil.

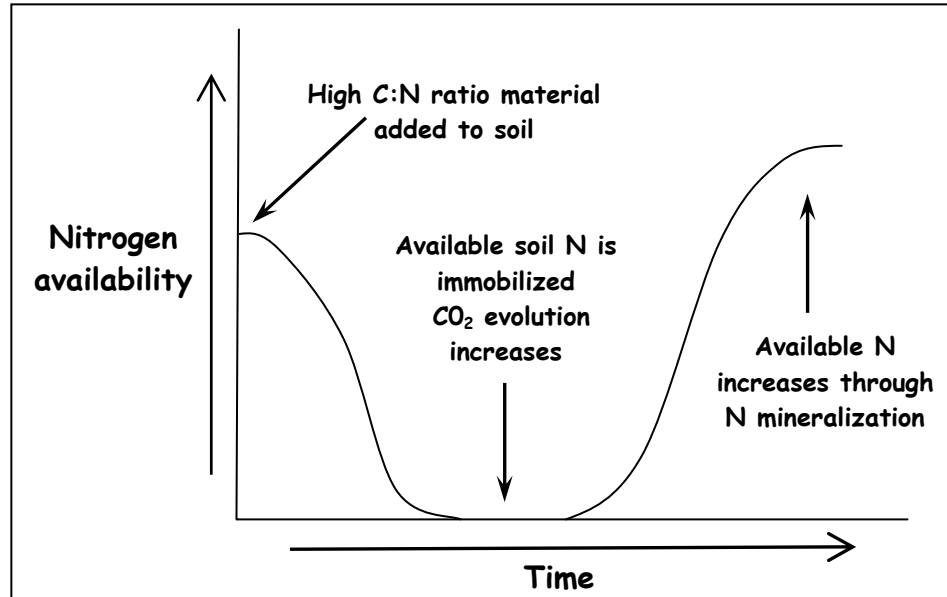

Nitrification

Nitrification is the biological oxidation of ammonium (NH_4^+) to nitrate (NO_3^-) in the soil. Sources of NH_4^+ for this process included both commercial fertilizers and the mineralization of organic residues. Nitrification is a two-step process where NH_4^+ is converted first to NO_2^- and then to NO_3^- by two autotrophic bacteria in the soil (*Nitrosomonas* and *Nitrobacter*). These bacteria get their energy from the oxidation of N and their C from CO_2 .

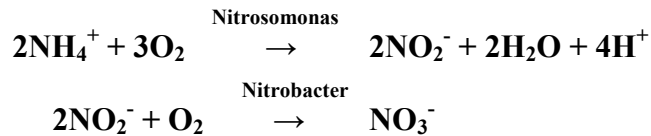

Nitrification is important because:

- Nitrate is readily available for uptake and use by crops and microbes.
- Nitrate is highly mobile and subject to leaching losses. NO_3^- leaching is generally a major N loss mechanism from agricultural fields in humid climates and under irrigation. Potential losses are greater in deep sandy soils as compared to fine textured soils. Nitrogen losses can be minimized through proper N management, including the proper rate and timing of N fertilizer applications.
- Nitrate-nitrogen ($\text{NO}_3\text{-N}$) can be lost through denitrification, the process where NO_3^- is reduced to gaseous nitrous oxide (N_2O) or elemental N (N_2) and lost to the atmosphere.

- During nitrification, 2 H⁺ ions are produced for every NH₄⁺ ion that is oxidized. These H⁺ cations will accumulate and significantly reduce soil pH; thus, any ammonium-containing fertilizer will ultimately decrease soil pH due to nitrification. This acidity can be managed through a well-planned liming program.

Note: The proper way to express NO₃⁻ concentrations is as NO₃-N or as elemental N. Use the following conversions, which are based on molecular weight:

- To convert NO₃-N to NO₃⁻: NO₃-N x 4.4 = NO₃⁻
- To convert NO₃⁻ to NO₃-N: NO₃⁻ x 0.23 = NO₃-N

Phosphorus

The phosphorus cycle

Soil phosphorus (P) originates primarily from the weathering of soil minerals such as apatite and from P additions in the form of fertilizers, plant residues, agricultural wastes, or biosolids (Figure 4.6). Orthophosphate ions (HPO₄⁻² and H₂PO₄⁻) are produced when apatite breaks down, organic residues are decomposed, or fertilizer P sources dissolve. These forms of P are taken up by plant roots and are present at very low concentrations in the soil solution.

Many soils contain large amounts of P (800 to 1600 lbs P/acre), but most of that P is unavailable to plants. The type of P-bearing minerals that form in soil is highly dependent on soil pH. Soluble P, regardless of the source, reacts very strongly with Fe and Al to form insoluble Fe and Al phosphates in acid soils and with Ca to form insoluble Ca phosphates in alkaline soils. Phosphorus in these insoluble forms is not readily available for plant growth and is said to be “fixed.”

Figure 4.6. The phosphorus cycle (modified from the Potash & Phosphate Institute web site at www.ppi-ppic.org).

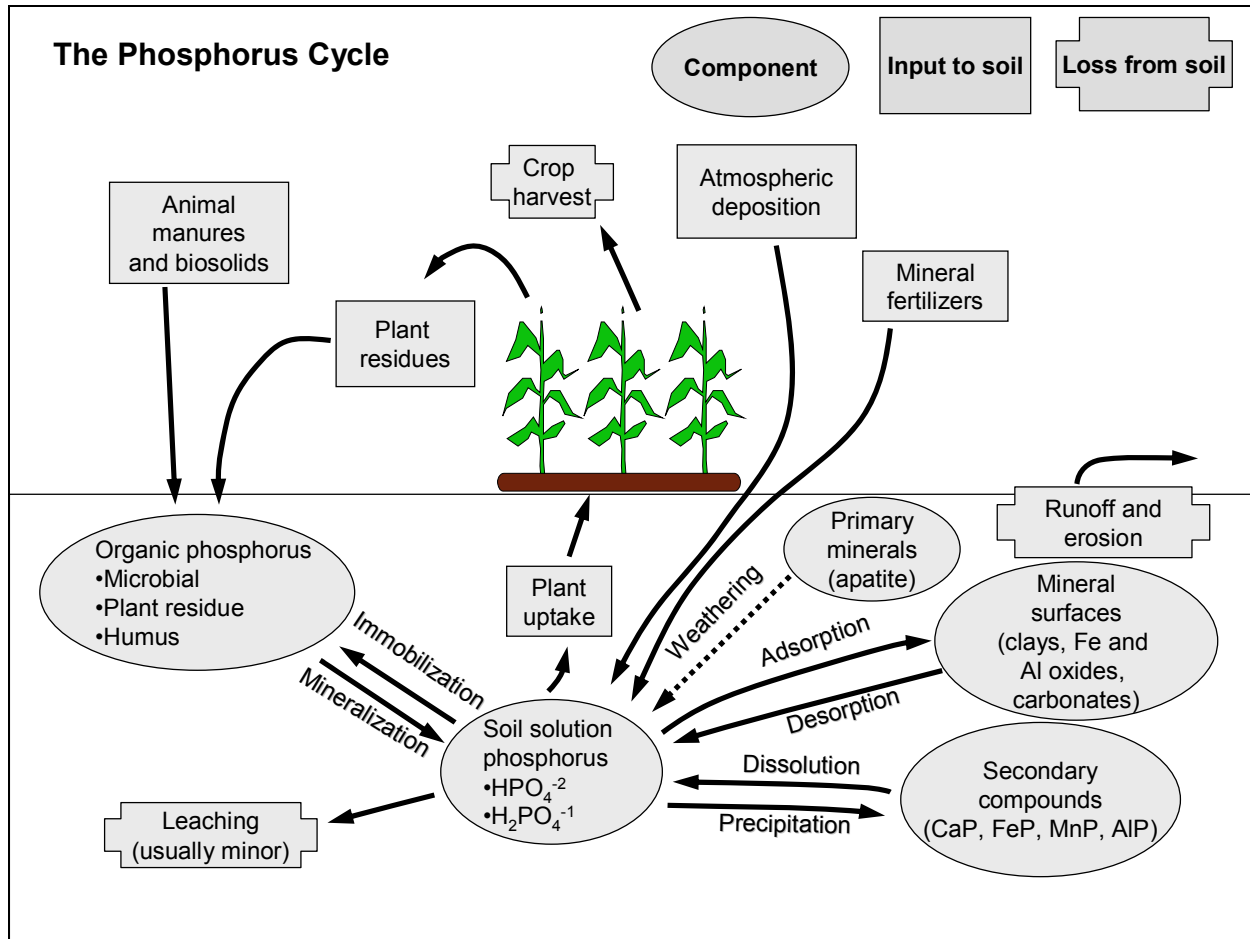

Phosphorus availability and mobility

Phosphorus is a primary nutrient and plant roots take up P in the forms of HPO_4^{2-} and H_2PO_4^- . The predominant ionic form of P present in the soil solution is pH-dependent. In soils with pH values greater than 7.2, the HPO_4^{2-} form is predominant, while in soils with a pH between 5.0 and 7.2, the H_2PO_4^- form predominates.

P has limited mobility in most soils because P reacts strongly with many elements, compounds, and the surfaces of clay minerals. The release of soil P to plant roots and its potential movement to surface waters is controlled by several chemical and biological processes (Figure 4.6). Phosphorus is released to the soil solution as P-bearing minerals dissolve, as P bound to the surface of soil minerals is uncoupled or *desorbed*, and as soil organic matter decomposes or *mineralizes* (Figure 4.7). Most of the P added as fertilizer and organic sources is rapidly bound by soil minerals in chemical forms that are not subject to rapid release; thus, soil solution P concentrations are typically very low. Soluble P in the soil solution of most agricultural soils ranges from

< 0.01 to 1 ppm; thus, an entire acre-furrow slice of soil generally contains less than 0.4 lb P in solution at any one time. As illustrated (Figure 4.7), supplying adequate P to a plant depends on the soil's ability to replenish the soil solution throughout a growing season.

Phosphorus availability and mobility is influenced by several factors:

- **Effect of soil pH:** In acid soils, P precipitates as relatively insoluble Fe and Al phosphate minerals. In neutral and calcareous soils, P precipitates as relatively insoluble Ca phosphate minerals. As illustrated in Figures 4.1 and 4.8, soil P is most available in the pH range of 5.5 to 6.8, which is where soluble Al and Fe are low.
 - **Movement of soil P to plant roots:** Phosphorus moves from soil solids to plant roots through the process of *diffusion*. Diffusion is a slow and short-range process with distances as small as 0.25 inches. This limited movement has important implications since soil P located more than 0.25 inches from a plant root will never reach the root surface. Dry soils reduce the diffusion of P to roots; therefore, plants take up P best in moist soils.
 - **Fertilizer P recovery:** A crop uses only 10 to 30% of the P fertilizer applied during the first year following application. The rest goes into reserve and may be used by later crops. Many growers in the Mid-Atlantic have built up large reserves of soil P.
 - **Timing and placement of P fertilizer:** Although most agricultural soils are naturally low in available P, many years of intensive P fertilization, the application of organic P sources, or both, has resulted in many soils that now test high in available P. On these soils, broadcast P applications are not very efficient. Low rates of P in starter fertilizers placed with or near the seed are potentially beneficial on high-P soils when the crop is stressed by cold conditions. Newly-planted crops need a highly available P source in order to establish a vigorous root system early in the season, but once the root system begins to explore the entire soil volume, there should be adequate amounts of plant available P to maintain crop growth.
-

Figure 4.7. Phosphorus content of the soil solution.

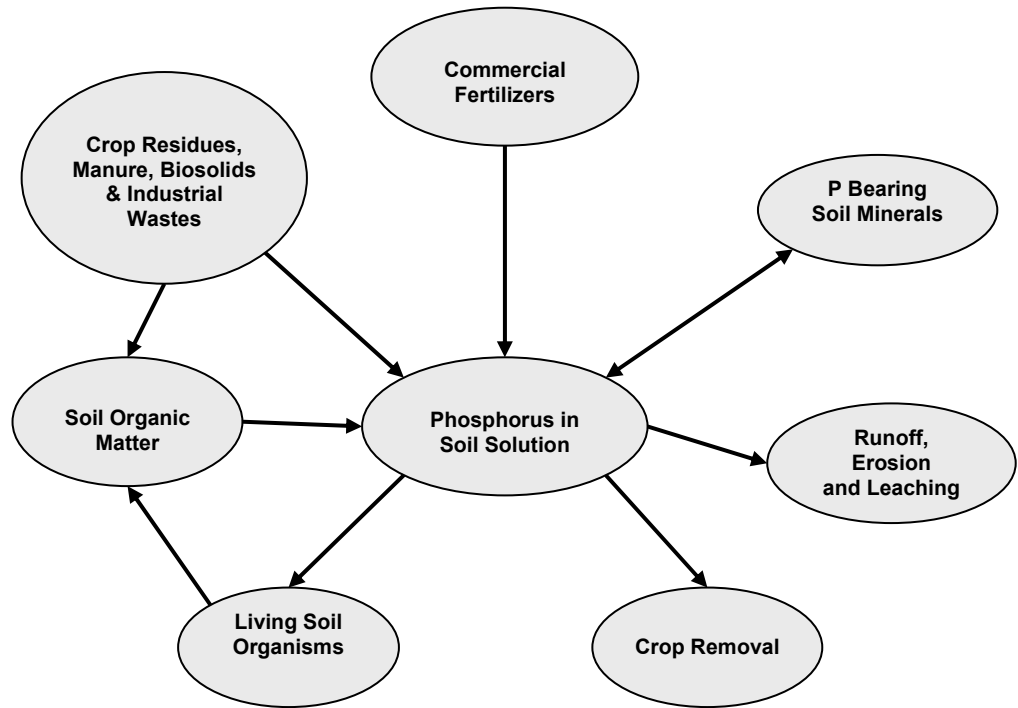
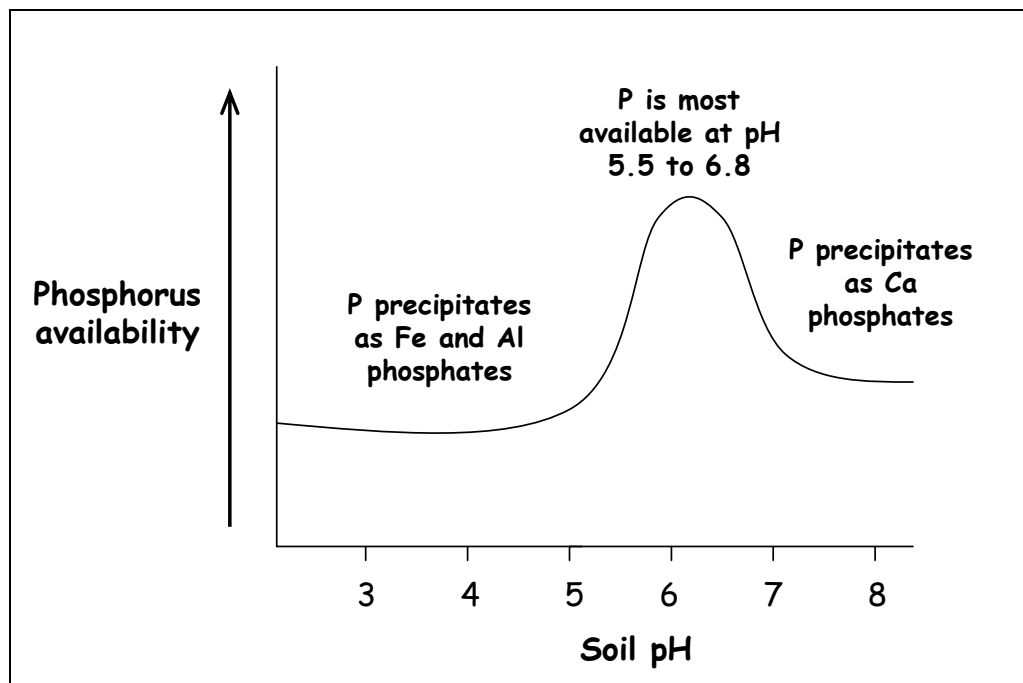

Figure 4.8. Effect of pH on P availability to plants.



Phosphorus transport to surface waters

Transport of soil P occurs primarily via surface flow (runoff and erosion). Although leaching and subsurface lateral flow should also be considered in soils with high degrees of P saturation and artificial drainage systems. Water flowing across the soil surface can dissolve and transport soluble P, or erode and transport particulate P, out of a field. Virtually all soluble P transported by surface runoff is biologically available, but particulate P that enters streams and other surface waters must undergo solubilization before becoming available for aquatic plants. Thus, both soluble and sediment bound P are potential pollutants of surface waters and both can contribute to excessive growth of aquatic organisms, which can have detrimental environmental impacts.

Soils have a finite capacity to bind P. When a soil becomes saturated with P, desorption of soluble P can be accelerated, with a consequent increase in dissolved inorganic P in runoff. **Thus, if the level of residual soil P is allowed to build up by repeated applications of P in excess of crop needs, a soil can become saturated with P and the potential for soluble P losses in surface runoff will increase significantly.** Recent research conducted in the Mid-Atlantic shows that the potential loss of soluble P will increase with increasing levels of soil test P. Very high levels of soil test P can result from over-application of manure, biosolids, or commercial phosphate fertilizer. Soils with these high soil test P levels will require several years of continuous cropping without P additions to effectively reduce these high P levels.

Potassium

The potassium cycle

Potassium is the third primary plant nutrient and is absorbed by plants in larger amounts than any other nutrient except N. Plants take up K as the monovalent cation K^+ . Potassium is present in relatively large quantities in most soils, but only a small percentage of the total soil K is readily available for plant uptake.

In the soil, weathering releases K from a number of common minerals including feldspars and micas. The released K^+ can be taken up easily by plant roots, adsorbed by the cation exchange complex of clay and organic matter, or “fixed” in the internal structure of certain 2:1 clay minerals. Potassium that is “fixed” by these clay minerals is very slowly available to the plant. The various forms of K in the soil are illustrated in Figure 4.9.

Figure 4.9. The potassium cycle (modified from the Potash & Phosphate Institute web site at www.ppi-ppic.org).

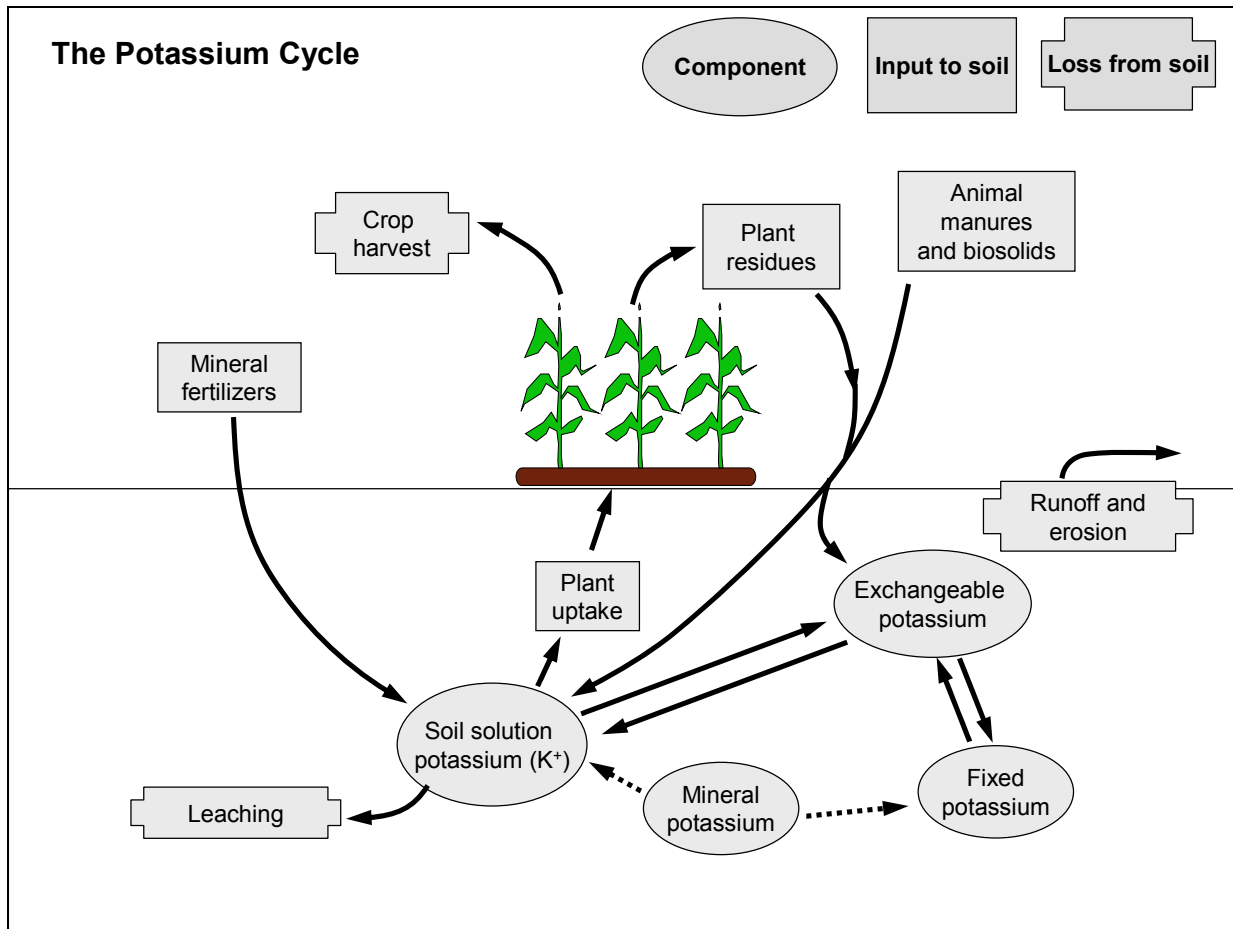

Potassium availability and mobility

- **Plant-available K:** Although mineral K accounts for 90 to 98% of the total soil K, readily and slowly available K represent only 1 to 10% of the total soil K. Plant available K (K that can be readily absorbed by plant roots) includes the portion of the soil K that is soluble in the soil solution and exchangeable K held on the exchange complex.
- **Exchangeable K** is that portion of soil K which is in equilibrium with K in the soil solution:



K is continuously made available for plant uptake through the cation exchange process. There can be a continuous, but slow, transfer of K from soil minerals to exchangeable and slowly available forms as K is removed from the soil solution by crop uptake and leaching.

- **Effect of K fertilization on soil K forms:** Potassium applied as fertilizer can have various fates in the soil:
 - Potassium cations can be attracted to the cation exchange complex where it is held in an exchangeable form and readily available for plant uptake.
 - Some of the K^+ ions will remain in the soil solution.
 - Exchangeable and soluble K may be absorbed by plants.
 - In some soils, some K may be “fixed” by the clay fraction.
 - Applied K may leach from sandy soils during periods of heavy rainfall.
 - **Movement of K in the soil:** Potassium moves more readily in soil than P, but less readily than N. Since K is held by cation exchange, it is less mobile in fine-textured soils and most readily leached from sandy soils. Most plant uptake of soil K occurs by diffusion.
-

Timing and placement of K fertilizer

Potassium fertilizers are completely water-soluble and have a high salt index; thus, they can decrease seed germination and plant survival when placed too close to seed or transplants. The risk of fertilizer injury is most severe on sandy soils, under dry conditions, and with high rates of fertilization. Placement of the fertilizer in a band approximately three inches to the side and two inches below the seed is an effective method of preventing fertilizer injury. Row placement of K fertilizer is generally more efficient than broadcast applications when the rate of application is low or soil levels of K are low.

A convenient and usually effective method of applying K fertilizers is by broadcasting and mixing with the soil before planting. Fertilizer injury is minimized by this method but, on sandy soils, some K may be lost by leaching.

Split application of K fertilizer on long-season crops such as alfalfa or grass crops that are harvested several times during the growing season is often recommended. *Luxury consumption* is a term used to describe the tendency of plants to take up K far in excess of their needs if sufficiently large quantities of available K are present in the soil. The excess K absorbed does not increase crop yields to any extent. Split application of K can minimize luxury consumption and provide adequate available K during the latter part of the growing season.

Secondary plant nutrients

Introduction

Secondary macronutrients, which include calcium (Ca), magnesium (Mg), and sulfur (S), are required in relatively large amounts for good crop growth. These nutrients are usually applied as soil amendments or applied along with materials which contain primary nutrients. Many crops contain as much or more S and Mg as P, but in some plants Ca requirements are greater than those for P. Secondary nutrients are as important to plant nutrition as major nutrients since deficiencies of secondary nutrients can depress plant growth as much as major plant nutrient deficiencies.

Calcium and magnesium

- **Behavior of Ca and Mg in the soil:** Calcium and Mg have similar chemical properties and thus behave very similarly in the soil. Both of these elements are cations (Ca^{2+} , Mg^{2+}), and both cations have the same amount of positive charge and a similar ionic radius. The mobility of both Ca and Mg is relatively low, especially compared to anions or to other cations such as Na and K; thus, losses of these cations via leaching are relatively low.
 - **Soil Ca:** Total Ca content of soils can range from 0.1% in highly weathered tropical soils to 30% in calcareous soils. Calcium is part of the structure of several minerals and most soil Ca comes from the weathering of common minerals, which include dolomite, calcite, apatite, and Ca-feldspars. Calcium is present in the soil solution and since it is a divalent cation, its behavior is governed by cation exchange as are the other cations. Exchangeable Ca is held on the negatively charged surfaces of clay and organic matter. Calcium is the dominant cation on the cation exchange complex in soils with moderate pH levels. Normally, it occupies 70-90% of cation exchange sites above pH 6.0.
 - **Soil Mg:** Total soil Mg content can range from 0.1% in coarse, humid-region soils to 4% in soils formed from high-Mg minerals. Magnesium occurs naturally in soils from the weathering of rocks with Mg-containing minerals such as biotite, hornblende, dolomite, and chlorite. Magnesium is found in the soil solution and, since it is a divalent cation (Mg^{2+}), its behavior is governed by cation exchange. Magnesium is held less tightly than Ca by cation exchange sites, so it is more easily leached; thus, soils usually contain less Mg than Ca. In the Mid-Atlantic region, Mg deficiencies occur most often on acid and coarse-textured soils.
-

Sulfur

- **Forms of sulfur and the sulfur cycle:** Most crops need less sulfur (S) relative to the other macronutrients. The S cycle for the soil-plant-atmosphere system is very similar to N and is illustrated in Figure 4.10. Soil

S is present in both inorganic and organic forms. Most of the sulfur in soils comes from the weathering of sulfate minerals such as gypsum; however, approximately 90% of the total sulfur in the surface layers of non-calcareous soils is immobilized in organic matter. Inorganic S is generally present in the sulfate (SO_4^{2-}) form, which is the form of sulfur absorbed by plant roots. Both soluble SO_4^{2-} in the soil solution and adsorbed SO_4^{2-} represent readily plant available S. Elemental S is a good source of sulfur, but it must first undergo biological oxidation to SO_4^{2-} , driven by *Thiobacillus thiooxidans* bacteria, before it can be assimilated by plants. This oxidation can contribute to soil acidity by producing sulfuric acid through the reaction:



- **Sulfur-containing fertilizers and soil acidity:** Several fertilizer materials contain the SO_4^{2-} form of S including gypsum (CaSO_4), potassium sulfate (K_2SO_4), magnesium sulfate (MgSO_4), and potassium magnesium sulfate (K-Mag, or Sul-Po-Mag). These fertilizer sources are neutral salts and will have little or no effect on soil pH. In contrast, there are other SO_4^{2-} containing compounds including ammonium sulfate ($(\text{NH}_4)_2\text{SO}_4$), aluminum sulfate ($(\text{Al}_2\text{SO}_4)_3$) and iron sulfate (FeSO_4) that contribute greatly to soil acidity. The SO_4^{2-} in these materials is not the source of acidity. Ammonium sulfate has a strong acidic reaction primarily because of the nitrification of NH_4^+ , and Al and Fe sulfates are very acidic due to the hydrolysis of Al^{3+} and Fe^{3+} .
- **Movement of sulfur:** Sulfate, a divalent anion (SO_4^{2-}) is not strongly adsorbed and can be readily leached from most soils. In highly-weathered, naturally acidic soils, SO_4^{2-} often accumulates in subsurface soil horizons, where positively charged colloids attract the negatively charged SO_4^{2-} ion. Residual soil SO_4^{2-} resulting from long term applications of S containing fertilizers can meet the S requirements of crops for years after applications have ceased.
- **Crop responses to sulfur:** Sulfur deficiencies are becoming more common in some areas since both S supplied by pollution and fertilizer-derived S have been reduced in recent years. Acid rain supplies some sulfur due to the emission of SO_2 during the burning of fossil fuels but lowered emissions have reduced the amount of S supplied to soil in rainfall. Commercial fertilizers previously contained significant amounts of S (i.e. normal superphosphate). With the adoption of high analysis fertilizers such as urea, triple superphosphate, and ammonium phosphates, which contain little or no S, application of this important plant nutrient has been reduced.

Figure 4.10. The sulfur cycle (modified from the Potash & Phosphate Institute web site at www.ppi-ppic.org).

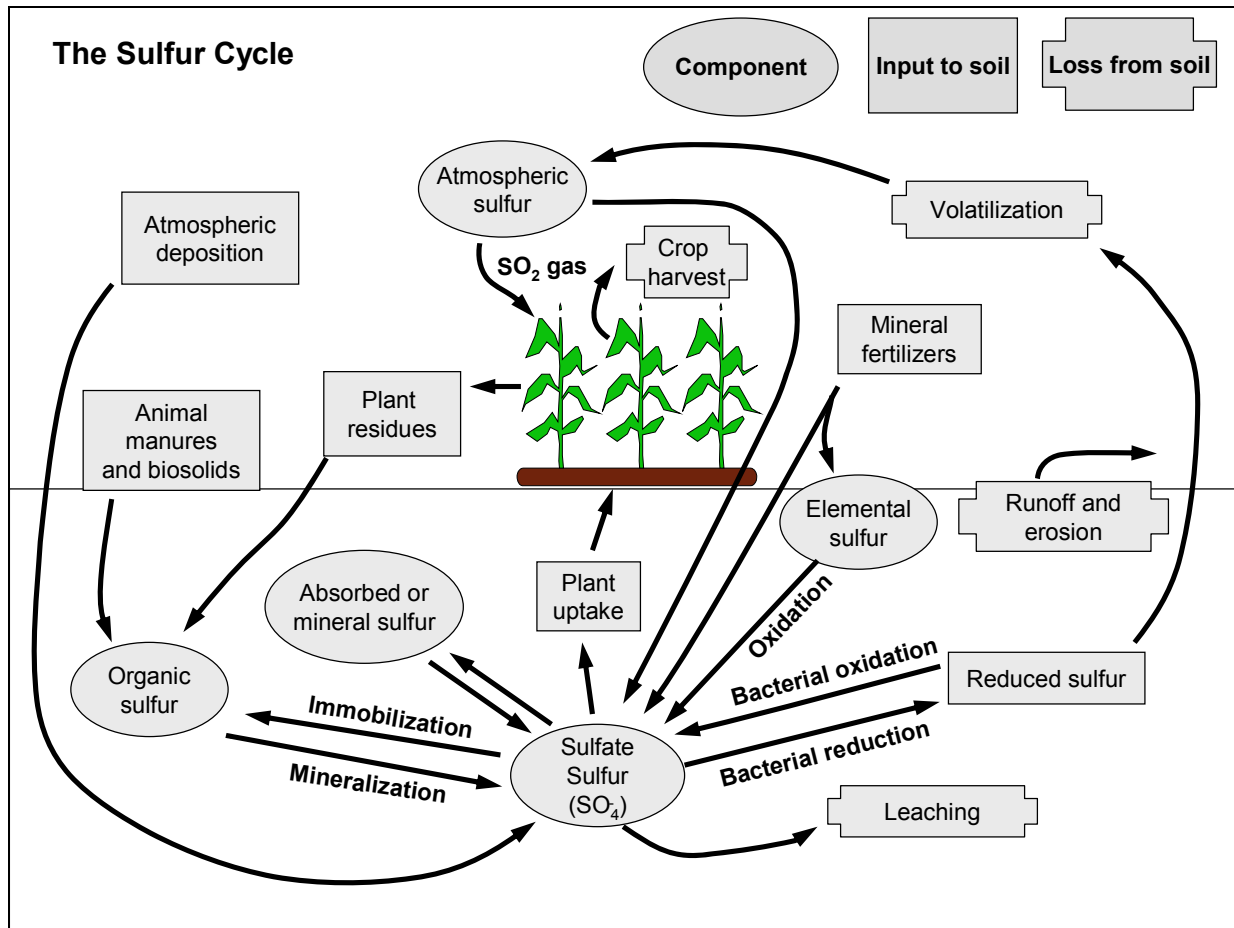

Micronutrients

Introduction

Eight of the essential elements for plant growth are called micronutrients or trace elements: B, Cl, Cu, Fe, Mn, Mo, Ni, and Zn. Cobalt (Co) has not been proven to be essential for higher plant growth, but nodulating bacteria need Co for fixing atmospheric N in legumes.

Micronutrients are not needed in large quantities, but they are as important to plant nutrition and development as the primary and secondary nutrients. A deficiency of any one of the micronutrients in the soil can limit plant growth, even when all other essential nutrients are present in adequate amounts.

Determining micronutrient needs

The need for micronutrients has been known for many years, but their wide use in fertilizers has not always been a common practice. Increased emphasis on micronutrient fertility has resulted from a number of factors, including:

- **Crop yields:** Increasing per-acre crop yields remove increasing amounts of micronutrients. As greater quantities of micronutrients are removed from the soil, some soils cannot release adequate amounts of micronutrients to meet today's high-yield crop demands.
- **Fertilizer technology:** Today's production processes for high-analysis fertilizers remove impurities much better than older manufacturing processes so micronutrients are not commonly provided as incidental ingredients in fertilizers.

Micronutrient fertilization should be treated as any other production input. A micronutrient deficiency, if suspected, can be identified through soil tests, plant analysis, or local field demonstrations. One should develop the habit of closely observing the growing crop for potential problem areas. Field diagnosis is one of the most effective tools available in production management.

Forms in the soil

Micronutrients can exist in several different forms in soil:

- within structures of primary and secondary minerals
- adsorbed to mineral and organic matter surfaces
- incorporated in organic matter and microorganisms
- in the soil solution

Many micronutrients combine with organic molecules in the soil to form complex molecules called chelates. A chelate is a metal atom surrounded by a large organic molecule.

Micronutrient soil-plant relationships

Plant roots absorb soluble forms of micronutrients from the soil solution. Soils vary in micronutrient content, and they usually contain lower amounts of micronutrients than primary and secondary nutrients. Total soil content of a micronutrient does not indicate the amount available for plant growth during a single growing season although it does indicate relative abundance and potential supplying power. Amounts of selected micronutrients taken up by selected crops are given in Tables 4.3a, b, and c. Availability decreases as pH increases for all micronutrients except Mo and Cl. Figure 4.1 shows the relationship between soil pH and availability for each micronutrient. Specific soil-plant relationships for B, Cu, Fe, Mn, Mo, Zn, and Cl are discussed in the next sections.

Boron

- **Soil boron:** Boron exists in minerals, adsorbed on the surfaces of clay and oxides, combined in soil organic matter, and in the soil solution. Organic matter is the most important potentially plant-available soil source of B.
 - **Factors affecting plant-available B:**
 - **Soil moisture and weather:** Boron deficiency is often associated with dry or cold weather, which slows organic matter decomposition. Symptoms may disappear as soon as the surface soil receives rainfall or soil temperatures increase and root growth continues, but yield potential is often reduced.
 - **Soil pH:** Plant availability of B is maximum between pH 5.0 and 7.0. Boron availability decreases with increasing soil pH; thus, B uptake is reduced at high pH.
 - **Soil texture:** Coarse-textured (sandy) soils, which are composed largely of quartz, are typically low in minerals that contain B. Plants growing on such soils commonly show B deficiencies. Boron is mobile in the soil and is subject to leaching. Leaching is of greater concern on sandy soils and in areas of high rainfall.
 - **Crop needs and potential toxicity:** Crops vary widely in their need for and tolerance to B; however, B should be applied judiciously because the difference between deficient and toxic amounts is narrower than for any other essential nutrient. This is especially important in a rotation involving crops with different sensitivities to B.
 - **Rates of boron fertilization:** Recommended rates of B fertilization depend on such factors as soil test levels, plant tissue concentrations, plant species, cultural practices (including crop rotation), weather conditions, soil organic matter, and the method of application. Depending on the crop and method of application, recommended rates of application generally range from 0.5 to 3 lbs/acre.
-

Copper

- **Soil copper:** In mineral soils, Cu concentrations in the soil solution are controlled primarily by soil pH and the amount of Cu adsorbed on clay and soil organic matter. A majority of the soluble Cu^{2+} in surface soils is complexed with organic matter, and Cu is more strongly bound to soil organic matter than any of the other micronutrients.
- **Copper deficiencies:** Organic soils are most likely to be deficient in Cu. Such soils usually contain plenty of Cu but hold it so tightly that only small amounts are available to the crop. Sandy soils with low organic matter content may also become deficient in Cu because of leaching losses. Heavy, clay-type soils are least likely to be Cu deficient. The concentrations of Fe, Mn, and Al in soil affect the availability of Cu for plant growth, regardless of soil type.

- **Copper toxicity:** Like most other micronutrients, large quantities of Cu can be toxic to plants. Excessive amounts of Cu depress Fe activity and may cause Fe deficiency symptoms to appear in plants. Such toxicities are not common.
-

Iron

- **Soil iron:** Iron is the fourth most abundant element, with total Fe ranging from 0.7 to 55%. Solubility of Fe is very low and is highly pH-dependent. Iron solubility decreases with increasing soil pH. Iron can react with organic compounds to form chelates or Fe-organic complexes.
- **Iron deficiencies:** Iron deficiency may be caused by an imbalance with other metals such as Mo, Cu, or Mn. Other factors that may trigger Fe deficiency include:
 - Excessive P in the soil.
 - A combination of high pH, high lime, wet, cold soils, and high bicarbonate levels.
 - Plant genetic differences. Plant species can differ significantly in their ability to take up Fe. Fe-efficient varieties should be selected where Fe deficiencies are likely to occur. Roots of Fe-efficient plants can improve Fe availability and uptake by secretion of H, organic acids and organic chelating compounds.
 - Low soil organic matter levels.

Reducing soil pH in a narrow band in the root zone can correct Fe deficiencies. Several S products will lower soil pH and convert insoluble soil Fe to a form the plant can use.

Manganese

- **Soil manganese:** Availability of Mn to plants is determined by the equilibrium among solution, exchangeable, organic and mineral forms of soil Mn. Chemical reactions affecting Mn solubility include oxidation-reduction and complexation with soil organic matter. Redox or oxidation-reduction reactions depend on soil moisture, aeration and microbial activity.
- **Manganese deficiencies:** Manganese solubility decreases with increasing soil pH:
 - Manganese deficiencies occur most often on high organic matter soils and on those soils with neutral-to-alkaline pH that are naturally low in Mn.
 - Manganese deficiencies may result from an antagonism with other nutrients such as Ca, Mg and Fe.
 - Soil moisture also affects Mn availability. Excess moisture in organic soils favors Mn availability because reducing conditions convert Mn^{4+} to Mn^{2+} , which is plant available.
 - Manganese deficiency is often observed on sandy Coastal Plain soils

- under dry conditions that have previously been wet.
- Several plant species have shown differences in sensitivity to Mn deficiencies.
-

Molybdenum

- **Soil molybdenum:** Molybdenum is found in soil minerals, as exchangeable Mo on the surfaces of Fe/Al oxides, and bound soil organic matter. Adsorbed and soluble Mo is an anion (MoO_4^-).
 - **Molybdenum deficiencies:** Molybdenum becomes more available as soil pH increases (Figure 4.1).
 - Deficiencies are more likely to occur on acid soils. Since Mo becomes more available with increasing pH, liming will correct a deficiency if the soil contains enough of the nutrient.
 - Sandy soils are deficient more often than finer-textured soils.
 - Soils high in Fe/Al oxides tend to be low in available Mo because Mo is strongly adsorbed to the surfaces of Fe/Al oxides.
 - Heavy P applications increase Mo uptake by plants, while heavy S applications decrease Mo uptake.
 - Crops vary in their sensitivity to low Mo and Mo-efficient/Mo-inefficient varieties have been identified for some plants species.
-

Zinc

- **Soil zinc:** The various forms of soil Zn include soil minerals, organic matter, adsorbed Zn on the surfaces of organic matter and clay, and dissolved Zn in the soil solution. Zinc release from soil minerals during weathering can be adsorbed onto the CEC, incorporated into soil organic matter, or react with organic compounds to form soluble complexes. Organically complexed, or chelated, Zn is important for the movement of Zn to plant roots. Soils can contain from a few to several hundred pounds of Zn per acre. Fine-textured soils usually contain more Zn than sandy soils.
- **Factors affecting plant-available Zn:** The total Zn content of a soil does not indicate how much Zn is available. The following factors determine its availability:
 - Zinc becomes less available as soil pH increases. Coarse-textured soils limed above pH 6.0 are particularly prone to develop Zn deficiency. Soluble Zn concentrations in the soil can decrease three-fold for every pH unit increase between 5.0 and 7.0.
 - Zinc deficiency may occur in some plant species on soils with very high P availability and marginal Zn concentrations due to Zn-P antagonisms. Soil pH further complicates Zn-P interactions.
 - Zinc forms stable complexes with soil organic matter. A significant portion of soil Zn may be fixed in the organic fraction of high organic matter soils. It may also be temporarily immobilized in the bodies of soil microorganisms, especially when animal manures are added to the soil.

- At the opposite extreme, much of a mineral soil's available Zn is associated with organic matter. Low organic matter levels in mineral soils are frequently indicative of low Zn availability.
 - Zinc deficiencies tend to occur early in the growing season when soils are cold and wet due to slow root growth. Plants sometimes appear to outgrow this deficiency, but yield potential may have already been reduced.
 - Zinc availability is affected by the presence of certain soil fungi, called mycorrhizae, which form symbiotic relationships with plant roots. Removal of surface soil in land leveling may remove the beneficial fungi and limit plants' ability to absorb Zn.
 - Susceptibility to Zn deficiency is both species and variety dependent. For example, corn, beans, and fruit trees have a high sensitivity to Zn deficiency.
-

Chlorine

- **Soil chlorine:** In soils, chlorine is found in the form of chloride (Cl^-), a soluble anion which is contained in negligible amounts in the mineral, adsorbed and organic soil fractions. Chloride has a high mobility in soils, which enables it to undergo extensive leaching when rainfall or irrigation exceeds evapotranspiration.
 - **Chloride fertilization:** About 60 lbs/acre of Cl^- per surface 2 feet of soil seems to be adequate for top yields of small grains. This amount can be provided by fertilizer or the soil. The most practical source is potassium chloride (KCl), or muriate of potash, which contains about 47% Cl. Preplant, at seeding, and topdressed applications have all been effective. Higher rates should be applied preplant or by topdressing. Since Cl^- is highly mobile in the soil, it should be managed accordingly.
-

References cited

- Bennett, W.F. (editor). 1993. Nutrient deficiencies and toxicities in crop plants. The American Phytopathological Society, St Paul, Minnesota.
- Brady, N.C. and R.R. Weil. 2002. Elements of the nature and properties of soils. 2nd ed. Prentice-Hall, Inc., Upper Saddle River, New Jersey.
- Havlin, J.L, J.D. Beaton, S.L. Tisdale, W.L. Nelson. 2005. Soil fertility and fertilizers, an introduction to nutrient management. 7th Ed. Pearson Education Inc., New Jersey.
- Jones, J. B., Jr. 1998. Plant nutrition manual. CRC Press LLC, Boca Raton, Florida.
- Maryland Nutrient Management Manual. 2005. Maryland Department of Agriculture. Available on-line at http://www.mda.state.md.us/resource_conservation/nutrient_management/manual/index.php.
- Marschner, H. 1995. Mineral nutrition of higher plants. 2nd Ed. Academic Press Inc., San Diego, CA.
- Pennsylvania Agronomy Guide, 2005-2006. 2005. Available on-line at <http://agguide.agronomy.psu.edu/cm/sec2/table1-2-8.cfm>.
- Plaster, E.J. 1996. Soil science and management. 3rd Ed. Selmar Publishers, New York.
- Sims, J.T., and K.L. Gartley. 1996. Nutrient management handbook for Delaware. Cooperative Bulletin No. 59. University of Delaware.
- PPI, 2003. Soil fertility manual. Potash and Phosphorus Institute, Norcross, Georgia. Web site: <http://www.ppi-ppic.org/>.
- Virginia Division of Conservation and Recreation, 2005. Virginia nutrient management standards and criteria (revised). VA DCR, Richmond VA.
-

Chapter 5. Crop Production

Thomas J. Basden

Center for Agricultural and Natural Resources Development, West Virginia University

A.O. Abaye

Department of Crop and Soil Environmental Sciences, Virginia Tech

Richard W. Taylor

Department of Plant and Soil Sciences, University of Delaware

Table of Contents

Introduction.....	96
Agronomic crops.....	96
Barley	96
Buckwheat.....	97
Corn, field	97
Corn, popcorn	98
Cotton.....	99
Oats	99
Peanuts	100
Rapeseed (canola)	100
Rye	101
Sorghum, grain (milo).....	101
Sorghum, sweet.....	102
Soybean.....	102
Sugar beet.....	103
Sunflower	103
Tobacco, burley.....	104
Tobacco, dark-fired.....	104
Tobacco, flue-cured	104
Tobacco, sun-cured.....	105
Wheat, winter.....	105
Nitrogen uptake and fertilization for corn and small grains	106
Corn.....	106
Small grains	107
Forage, hay, and cover crops	109
Alfalfa	109
Alsike clover	110
Austrian winter pea and field pea	110
Bermudagrass.....	111
Birdsfoot trefoil.....	111
Bluegrass, Kentucky	112
Bromegrass, smooth.....	112
Caucasian bluestem.....	112
Comfrey, Quaker (Russian comfrey).....	113

Crimson clover.....	113
Crownvetch.....	114
Eastern gamagrass.....	114
Fescue, sheep's	114
Fescue, tall	115
Lespedeza bicolor	116
Lespedeza, Korean and Kobe	116
Lespedeza, Sericea.....	116
Matua prairiegrass.....	117
Millet, foxtail	117
Millet, pearl.....	118
Orchardgrass	118
Red clover	119
Redtop	119
Reed canarygrass	120
Ryegrass, annual and perennial.....	120
Sorghum, forage.....	121
Sudangrass and sorghum-sudangrass hybrid	121
Sweet clover.....	121
Switchgrass	122
Tall meadow oatgrass	122
Timothy.....	123
Vetch, hairy.....	123
White clover, common.....	123
White clover, ladino.....	124
Links to information on turfgrass, fruit, and vegetable production	125
References cited.....	126
References for additional information	126

Introduction

The following lists of agronomic, forage, hay, and cover crop descriptions are condensed from Part I of the Virginia Tech Agronomy Handbook (Brann et al., 2000), with some modifications based on recommendations from the University of Delaware. **These are meant to be a general guide only.** For specific fertilizer recommendations and planting/harvest dates for your area, or more details on a particular crop, please consult your state Cooperative Extension Service, or see:

- Penn State Agronomy Guide: <http://agguide.agronomy.psu.edu/>
- Virginia Tech Agronomy Handbook: <http://www.ext.vt.edu/pubs/agronomy/>

Other useful regional websites include:

- Agronomic Crop Nutrient Recommendations Based on Soil Test and Yield Goal (Maryland Cooperative Extension): <http://www.agnr.umd.edu/MCE/Publications/PDFs/SFM1.pdf>
 - Maryland Cropping Systems Research and Extension page: <http://www.nrsl.umd.edu/extension/crops/>
 - University of Delaware Cooperative Extension Agronomy page: <http://ag.udel.edu/extension/agnr/agronomy.htm>
 - West Virginia University Extension Service Field Crops page: <http://www.wvu.edu/%7Eagexten/flcprps/index.htm>
-

Agronomic crops

Barley

Barley (*Hordeum vulgare*) is an annual whose grain is used primarily for animal feed. Barley is also used for silage and in mixtures with other small grains for cover crops and winter grazing and has limited use in human food.

- **Fertilization:** For N, see “Nitrogen uptake and fertilization for corn and small grains” section. Apply P and K according to soil test recommendations. These applications should be large enough to supply nutrients to the succeeding crop if the small grain will be double-cropped. Split applications of K are preferred on soils with high leaching potential.
- **Nutrients of Special Interest:** Sulfur deficiencies can occur on coarse-textured soils with low organic matter contents. The entire S requirement should not be applied at planting due to loss potential. Apply 10 to 15 lbs

S/A to S deficient soils with the first N application in late winter/early spring. Determine S tissue content at Zadoks' growth state 30, and if the N: S ratio is greater than 15:1; apply recommended S with the growth stage 30 N application.

- **Soil pH Range:** 6.0-6.5. Barley is very sensitive to low pH and very sensitive to low available Mn levels on sandy soils if the pH is too high.
 - **Approximate Planting Date:** About 2 weeks before first average frost in fall.
 - **Harvesting:**
 - Grain: Combine when fully ripe and 12-14% moisture.
 - Silage: Cut in the soft dough stage or boot stage depending on forage requirements.
 - **Approximate Harvest Dates:** Grain: June 1-June 20; Silage: May 1-June 1
-

Buckwheat

Buckwheat (*Fagopyrum esculentum*) is an annual plant whose grain is used as livestock feed, particularly poultry feed, or is ground into flour. It is a good honey and green manure crop.

- **Fertilization:** 20-30 lbs N/A. Apply P and K according to soil test recommendations.
 - **Soil pH Range:** 5.5-6.0
 - **Approximate Planting Date:** Latter part of May to middle of July. Seeds do not set well in warm weather. Likes cool, moist climate. No-till can work well.
 - **Harvesting:** Combine grain when the maximum numbers of seeds are mature and plants have lost most of their leaves. Drying may be necessary for safe storage.
 - **Approximate Harvest Date:** Early to mid-September.
-

Corn, field

Field corn or maize (*Zea mays*) is an annual whose grain is used for livestock or poultry feed, human food products, and silage.

- **Fertilization:** For N, see following section: "Nitrogen uptake and fertilization for corn and small grains." Apply P and K according to soil test recommendations. For silage, increase the amount of P applied by 1/3, and double the amount of K.

- **Nutrients of Special Interest:** In coarse-textured Coastal Plain soils with low organic matter, sulfur deficiency can occur upon leaching of sulfate into the finer textured subsoil. Rates of 20-50 lbs S/A are sufficient for high corn yields where conditions favor S deficiency.
- **Soil pH Range:** 5.8-6.2
- **Approximate Planting Dates:** Full-season corn should be planted one week before to one week after average date of last killing frost in spring. Corn will germinate at 50° F, but growth rate is slow until temperatures reach 60° F. Double-crop corn can be planted up to July 1.
- **Harvesting:**
 - Silage: Harvest at hard dough stage when kernels are dented, a black layer has formed at their bases, and lower leaves and husks are turning brown. Dry matter content should be 35-42%.
 - Grain: Corn is mature at 30-35% moisture. A black layer of cells is formed at the base of the kernel at maturity. If corn is harvested with a picker and cribbed, the moisture content should be no more than 20%. The optimum moisture for field shelling is between 18% and 26%. It should be dried to 13% moisture before storage.
- **Approximate Harvest Dates:** Silage: August - October; Grain: September -November.

Note: If growing **reduced-tillage or no-till corn**, an annual cover such as small grain, permanent sod, or mulch from a previous crop, is important for success. Herbicides are used to kill existing vegetation and reduce weed competition throughout the season. A specially designed planter is used to plant the corn in the mulch with no soil preparation.

Corn, popcorn Popcorn (*Zea mays everta*) is similar to field corn but is used for confection and meal.

- **Fertilization:** Same as field corn.
- **Soil pH Range:** Same as field corn.
- **Approximate Planting Date:** 1-2 weeks after date of last killing frost.
- **Approximate Harvest Date:** Shuck from standing stalks after it is thoroughly ripe. Maximum popping expansion is reached when kernel moisture is about 13-14%.

Cotton

Cotton (*Gossypium hirsutum*) is an annual grown primarily for fiber; seed used for stock feed, fertilizer and oil. It is adapted to the eastern shore and southeastern area of Virginia.

- **Fertilization:** 50-70 lbs N/A. Apply P and K according to soil test recommendations. Sidedress with 25-75 lbs N/A.
 - **Nutrients of Special Interest:** Cotton is very sensitive to deficiencies of N, K, S, and B. These nutrients can be removed by leaching rains in coarse-textured soils. Recommended rates of N, K, S, and B are based on long-term field trials over a wide range of conditions. Split applications may be required to improve fertilizer efficiency, and to ensure adequate availability throughout the growing season on soils subject to leaching,
 - **Soil pH Range:** 5.8- 6.5. The optimum pH for cotton ranges from 6.2 to 6.5. Of the crops grown in the East, cotton is among the most sensitive to soil acidity. Marked growth and yield increases have repeatedly occurred when lime was applied to acidic soils. When soil pH drops below 5.5, aluminum and manganese limit early plant growth, resulting in fewer and smaller bolls with poor lint quality.
 - **Approximate Planting Dates:** After soil begins to warm, usually about April 5-May 1.
 - **Approximate Harvest Dates:** Mid to late fall.
-

Oats

Oat (*Avena sativa*) is an annual used for grain, hay, and grazing. Oat is an excellent rotational crop for wheat or barley because it is not susceptible to the same range of diseases.

- **Fertilization:** 20 lbs of N/A in the fall. Apply P and K according to soil test recommendations. Topdress with 60-80 lbs of N/A in February or early March. These rates assume no carry over N from the previous crop.
- **Soil pH Range:** 6.0-6.5
- **Approximate Planting Dates:**
 - Winter oats: Fall and midwinter. Not recommended west of the Blue Ridge.
 - Spring oats: March-April. Not recommended for the Coastal Plain. Although they can be grown there, this usually results in lower yields than winter oat crops.

- **Harvesting:**
 - Hay: Cut in boot to early dough stage.
 - Seed: Combine when fully ripe at 10-15% moisture.
 - **Approximate Harvest Dates:**
 - Winter oats: Late June to early July.
 - Spring oats: Early to mid July.
-

Peanuts

Peanut (*Arachis hypogaea*) is an annual legume plant used for food for humans and livestock. Peanut cross-inoculates with lespedezas, cowpeas, and kudzu. The best quality peanuts are produced on well drained, light, sandy soils.

- **Fertilization:** Direct fertilization is not recommended. Increase the fertilizer application to the crop that precedes peanuts in rotation by 50-100 lbs P₂O₅ and 10-60 lbs K₂O, depending on soil test levels. Apply 900 lbs gypsum broadcast or 600 lbs banded over the row as plants begin to bloom.
 - **Soil pH Range:** 5.8-6.5
 - **Approximate Planting Date:** April 20-May 10. Soil temperature should be at least 65° F for three consecutive days.
 - **Harvesting:** Dig when approximately 70% of the shells turn brown on the inside (usually 130-170 days after planting).
 - **Approximate Harvest Date:** September 15-November 1.
-

Rapeseed (canola)

Rapeseed, or canola, (*Brassica napus*) is a cool season annual in the mustard family that reaches a height of 3-6' at maturity. Winter and spring varieties are available. It is used for an oil crop and for pasture. It is usually ready for grazing about 8 weeks after seeding.

- **Fertilization:** 60-80 lbs N/A. Apply P and K according to soil test recommendations.
- **Nutrients of Special Interest:** Rapeseed is very responsive to sulfur fertilization. Sulfur deficiencies can reduce both yield and crop quality.
- **Soil pH Range:** 5.2-6.2
- **Approximate Planting Date:** February and March, or August and September. Fall planting is recommended for canola oil crop.

- **Approximate Harvest Dates:** Harvest for oil when the seeds have dried to 15% moisture or less (9-12% preferable).
-

Rye

Rye (*Secale cereale*) is an annual, and is the most winter-hardy of small grains. Rye performs better on low productivity soils than wheat, oats, or barley. It is used for cover crop, grain, silage, and winter and spring pasture conditions.

- **Fertilization:** For N, see “Nitrogen uptake and fertilization for corn and small grains” section. Apply P and K in fall, according to soil test recommendations. If the small grain will be double-cropped, these applications should be large enough to supply nutrients to the succeeding crop. Split applications of K are recommended on soils with high leaching potential.
 - **Nutrients of Special Interest:** Sulfur deficiencies can occur on coarse-textured soils with low organic matter contents. Apply 10 to 15 lbs S/A to S deficient soils with the first N application in late winter/early spring. Determine S tissue content at Zadoks’ growth state 30, and if the N: S ratio is greater than 15:1; apply recommended S with the growth stage 30 N application.
 - **Soil pH Range:** 5.8-6.2
 - **Soil Adaptation:** Any well drained soil.
 - **Approximate Planting Date:** Plant 2 weeks before to 4 weeks after first killing frost.
 - **Harvesting:**
 - Grain: Combine when fully ripe at 10-15% moisture. Rye ripens slowly and the seed is easily damaged during harvesting.
 - Silage: Harvest at the boot stage.
 - Pasture: Earlier fall planting allows some late fall grazing. Stock heavily and rotationally to maintain leafy growth.
 - **Approximate Harvest Dates:** Grain: Mid-June - July; Silage: April - May.
-

Sorghum, grain (milo)

Grain sorghum, or milo, (*Sorghum bicolor*) is the same genus and species as forage sorghum. Shorter plant types that produce lighter colored grain have been bred. Milo will recover from high temperature and drought more easily than corn. It is used for grain and silage.

- **Fertilization:** Apply 0-25 lbs N/A following a good soybean crop or winter

legume cover crop and no more than 50 to 75 lbs N/A if following a previous grass (corn or milo) crop. Uses approximately the same amount of P and K that would be applied to corn when grown under comparable conditions.

- **Soil pH Range:** 5.8-6.2
 - **Approximate Planting Date:** 1-2 weeks after corn, when soil temperatures are at least 65° F and expected to rise. Early-medium maturing hybrids can be planted following small grain harvest.
 - **Harvesting:**
 - Grain: Harvest grain with combine when seed is mature and shells easily from the head.
 - Silage: Chop for silage when the grain is in the dough stage.
-

Sorghum, sweet Sweet sorghum (*Sorghum bicolor* var *saccharum*) is similar in appearance to forage sorghum and is used for syrup.

- **Fertilization:** 30-50 lbs N/A. Apply P and K according to soil test recommendations. Sidedress N to provide a total of no more than 70 lbs N/A when plants are 25-35 days old.
 - **Soil pH Range:** 5.8-6.2
 - **Approximate Planting Date:** 2-4 weeks after corn at 3-5 lbs in rows 30-36 inches apart. Plant 1 to 1 ½ inches deep.
 - **Harvesting:** When seeds are in hard-dough stage.
 - **Approximate Harvest Date:** September 1-October 1.
-

Soybean Soybean (*Glycine max*) is an annual legume that is used for seed, hay, and silage. Soybean should be rotated with non-legume crops.

- **Fertilization:** Apply no N. Apply P and K according to soil test recommendations. Little or no yield response to added P can be expected from soybeans grown on soils testing high in P. If soil tests show a low, or sometimes a medium P level, P application will usually increase yields. Yield response to added K when soil test levels are medium or above is rare so direct K application may not always be needed. Potassium application may be split on coarse-textured soils to improve efficiency.
- **Nutrients of Special Interest:** Soybeans need 20 to 25 lbs/A of S for top

yields. Some S is present in organic matter and a sizeable quantity (1 to 15 lbs/A) is supplied through rainfall. Soil testing or plant analysis should be used to determine whether supplemental S additions are needed.

- **Soil pH Range:** 5.8-6.5
 - **Approximate Planting Date:** Up to two weeks after corn planting time for the area for full-season beans, or generally after June 15 if double-cropped with small grain. Requires soybean inoculum where soybeans are not grown regularly. Yield declines rapidly if planted later due to lack of time to develop adequate growth.
 - **Harvesting:**
 - Hay and silage: Harvest when lower leaves begin to turn yellow and pods are about half-filled.
 - Seed: Harvest when leaves have fallen, pods are brown and dry, and seed moisture is 10-15%.
 - **Approximate Harvest Dates:** Hay: August-October; Seed: September-December 1.
-

Sugar beet

Sugar beets (*Beta vulgaris*) are a biennial crop used for sugar production and livestock feed.

- **Fertilization:** 40 lbs N/A. Apply P and K according to soil test recommendations. An additional 40 lbs N/A will be needed 4-6 weeks later. Use a borated fertilizer.
 - **Soil pH Range:** 6.0-6.5
 - **Approximate Planting Date:** Late winter or early spring.
 - **Approximate Harvest Dates:** October-December.
-

Sunflower

Sunflower (*Helianthus annuus*) is a tall annual used for oil crop, bird feed, and snack food.

- **Fertilization:** 100 lbs of N/A. Apply P and K according to soil test recommendations.
- **Soil pH Range:** 5.8-6.0
- **Approximate Planting Date:** Tolerates freezing temperatures better than most crops. Can plant 2-3 weeks prior to last killing frost. Because of early

maturity, planting can continue until August 1 in southeastern Piedmont and southern Coastal Plain.

- **Approximate Harvest Date:** 110-120 days are required from planting to harvest. The seeds are mature when the backs of flower heads turn yellow.
-

Tobacco, burley

Burley tobacco (*Nicotiana tabacum*) is grown from transplants that are usually produced in greenhouses. It is used primarily for cigarette blends, with a small amount used in pipe and chewing tobacco products.

- **Fertilization:** 175-200 lbs of N/A. Apply P and K according to soil test recommendations.
 - **Soil pH Range:** When checked in the spring, a pH of 5.8-6.2 is preferred. If the pH drops to 4.9 during the season, there is a danger of manganese toxicity.
 - **Approximate Planting Date:** Transplant mid-May to early June.
 - **Approximate Harvest Date:** Mid-August to October 1.
-

Tobacco, dark-fired

Dark fired tobacco (*Nicotiana tabacum*) is primarily exported for the manufacture of smoking tobacco, chewing tobacco, and cigars. Domestically, it is used for dry snuff.

- **Fertilization:** 135 lbs N/A. Apply P and K according to soil test recommendations.
 - **Soil pH Range:** 5.6-6.0
 - **Approximate Planting Date:** May 1-June 1.
 - **Approximate Harvest Date:** August 15-September 1.
-

Tobacco, flue-cured

Flue-cured tobacco (*Nicotiana tabacum*) is an annual grown from transplants, which are usually produced in greenhouses. It is primarily used in cigarettes.

- **Fertilization:** 50-80 lbs N/A. If necessary to topdress, use nitrate source of N. Apply P and K according to soil test recommendations. Use materials low in chlorine (less than 2%). Preplant fertilizer rates should not exceed 40 lbs of N and 120 lbs K₂O per acre. Additional N and K₂O can be applied as a side application to obtain the total amount of nutrients desired.

- **Soil pH Range:** 5.5-6.0
 - **Approximate Planting Date:** Transplant from April 25-May 20.
 - **Approximate Harvest Date:** Typically three harvests or primings as leaves ripen. Harvest period may last 8-12 weeks, beginning as early as mid-July and ending as late as October.
-

Tobacco, sun-cured

Sun-cured tobacco (*Nicotiana tabacum*) has smaller plants than flue cured and is primarily exported for making smoking and chewing tobacco. A small portion is used domestically for plug chewing tobacco.

- **Fertilization:** 125 lbs N/A. Apply P and K according to soil test recommendations.
 - **Soil pH Range:** 5.6-6.0
 - **Approximate Planting Date:** May 1 - June 1
 - **Approximate Harvest Date:** August to early September.
-

Wheat, winter

Winter wheat (*Triticum aestivum*) is an annual used for grain, grazing, and cover crops.

- **Fertilization:** For N, see “Nitrogen uptake and fertilization for corn and small grains” section. Apply P and K in fall according to soil test recommendations. These applications should be large enough to supply nutrients to the succeeding crop if the small grain will be double cropped. Split applications of K are recommended on soils with high leaching potential.
- **Nutrients of Special Interest:** Sulfur deficiencies can occur on coarse-textured soils with low organic matter content. Apply 10 to 15 lbs S/A to S deficient soils with the first N application in late winter/early spring. Determine S tissue content at Zadoks’ growth stage 30, and if the N: S ratio is greater than 15:1; apply the recommended amount of S with the growth stage 30 N application.
- **Soil pH Range:** 5.8-6.2
- **Approximate Planting Date:** After the Hessian fly-free date (or approximately one week before to one week after the first killing frost).
- **Approximate Harvest Dates:** Mid-June to July

Nitrogen uptake and fertilization for corn and small grains

Corn

- **N Uptake:** Efficient fertility management of corn is critical to water quality because corn has among the highest N requirements of all crops (125-150 lbs/A). During the first 25 days after emergence, corn will utilize only 10% of its total N requirements (Figure 5.1). If the entire portion of N is applied at planting, the portion that is not utilized immediately can be lost through leaching, surface runoff, soil erosion, and denitrification.
- **N Application:** By applying approximately 30 lb/A of N at planting, and delaying the larger application until the corn is 12 to 18 inches tall, a greater portion of the applied N will be used by the crop and less will be lost to surface water and groundwater. On fine textured soils, applying the sidedress N shortly after the 12 inch stage is suggested so that rainfall will position the N in the corn rooting area in time for the maximum crop N demand. Thus, on a farm with contrasting soil textures, one should begin sidedressing soils with the most clay, followed by sandier soils. By efficiently applying N in split applications, corn can generally be grown on approximately 1 lb of N per bushel of expected yield.

For most efficient use, N applied at planting time should be banded 2 inches beside and 2 inches below the row at the rate of 20-40 lbs/A. Alternatively, if N must be broadcast at planting due to the lack of a starter fertilizer attachment, 50-70 lbs, or no more than 50% of the total crop needs, should be applied at planting. This is particularly important on environmentally sensitive sites such as soils with a high leaching index. The use of low N, high P banded fertilizers should be avoided since not enough N will be concentrated near the young corn plant for optimum growth. Banded fertilizer grades that achieve application rates of 30-0-0, 30-15-0, or 30-30-0 lbs/A N-P₂O₅-K₂O are recommended depending on the P soil test results.

Figure 5.1. Nitrogen uptake by corn.

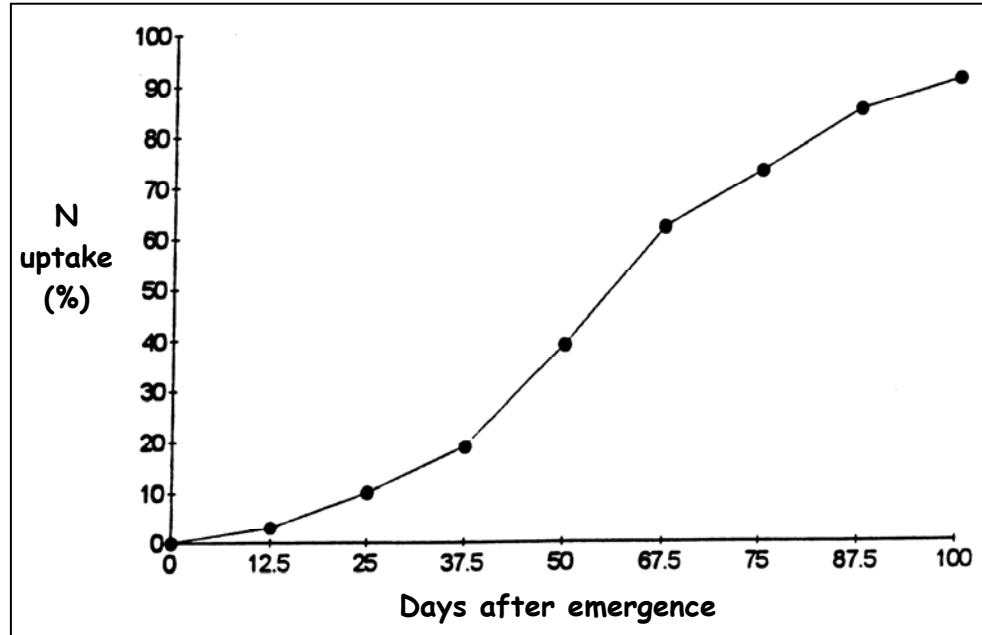

Small grains

- **N Uptake:** Small grain crops (wheat, barley, and rye) use relatively small amounts of N in the fall. Most uptake begins in late winter at the time of jointing (Figure 5.2).

- **N Application:**

- At-Planting Application: When using conventional tillage, broadcast and incorporate up to 30 lbs N/A during land preparation for planting. If no-till is used, broadcast up to 30 lbs N/A shortly after planting.
- Midwinter Application: In the southern portion of the Chesapeake Bay Region (i.e., Virginia) and on very sandy soils, a midwinter (December-January) N application may be needed if the crop is developing slowly.

Three conditions should be met before this application is made. These are:

- There have been two or more rainfall events of 2 inches or more each during the October-December period.
- There are less than three *tillers* (a tiller is a shoot with three leaves/collars visible) per plant and the crop has a pale green color.
- The long range weather outlook indicates there may be several days during December and January in which maximum temperature will exceed 50° F.

If these conditions are met, apply 30 lbs N/A.

- Late Winter Applications: (February - Early March): Research on N management in small grain production continues to show advantages to dividing this application between Zadoks' growth stage 25 and at Zadoks' growth stage 30 (Figure 5.3). Topdress with 30-50 lbs of N in February if the stand is thin or shows obvious nitrogen deficiency. Additional nitrogen should be applied in late March (40-80 lbs).

Figure 5.2. Nitrogen uptake by winter wheat

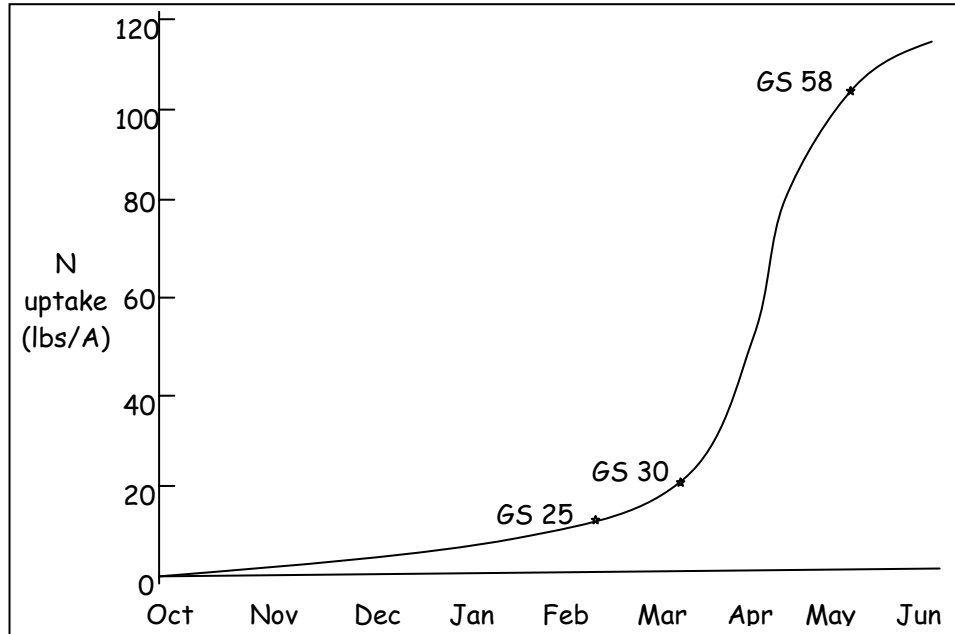
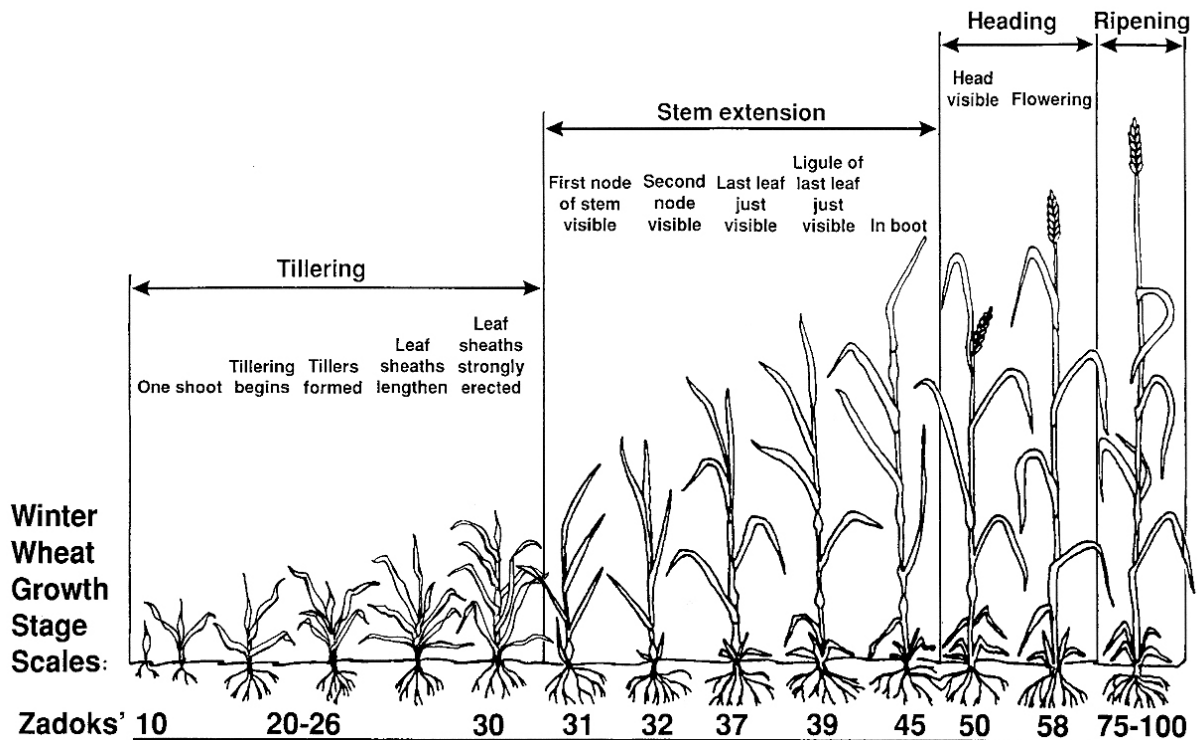

Figure 5.3. Zadoks' growth stages of winter wheat (adapted from Alley et al, 1993).



Forage, hay, and cover crops

Alfalfa

Alfalfa (*Medicago sativa*) is a perennial used for hay, pasture, and silage. Inoculation is essential. The inoculant is a live bacterial spore and should be handled to ensure that it remains live. Alfalfa cross-inoculates with sweet and bur clover. Lime-coated preinoculated seed can be used but be certain that the seed is not more than 9 to 12 months old at the time of planting, and that it has been stored correctly.

- **Fertilization:** At seeding, use 20-30 lbs N/A. Apply P and K according to soil test recommendations. Fertilizer should be split-applied, with about half applied after the first or second cutting and the second half applied after the August or early September cutting. Fertilizing during the late-summer or early fall helps plants survive the winter and make a vigorous early start next spring. Lower levels of fertilizer are required for pasture.
- **Nutrients of Special Interest:** Use borate fertilizers at a rate of 2 lbs B/A in split applications with P and K. Alfalfa may respond to S application in some instances.

- **Soil pH Range:** 6.8-7.0. If the pH is 6.0 or below, apply lime at least 6 months before the alfalfa is seeded and retest the soil prior to actually seeding the crop so additional lime can be added if the soil pH has not risen adequately.
- **Approximate Planting Dates:** 30-60 days before first killing frost in fall or 30 days before last killing frost in spring.
- **Harvesting:**
 - Hay or silage: Harvest at late bud to 1/4 bloom, except first cutting. First cutting should be made in bud stage or when orchardgrass begins to head. Alfalfa may be cut 3-5 times/year at 30-40 day intervals, depending upon location and average rainfall. Make last cutting 3-4 weeks before average date of first killing frost in fall or in time to allow 6-8 inches of regrowth. Allow at least one harvest to reach 1/10 bloom to help persistence.
 - Pasture: Use grazing-tolerant varieties under continuous stocking. Hay-type varieties should be rotationally stocked with 1-7 day grazing periods and 25-40 day rest periods. Avoid bloat by seeding with grass, turning cattle into new paddock only after forage is dry (no dew), and not allowing cattle to get too hungry prior to turn in.

Alsike clover

Alsike clover (*Trifolium hybridum*) is a perennial used for hay and pasture but it does not sufficiently recover after the first cutting for a second hay crop. Inoculation of alsike clover is important for establishment. It cross-inoculates with red, crimson, ladino, and white clover. Alsike is more tolerant of a high water table and/or acid soils than some clovers. Avoid using for grazing horses since the crop can cause photosensitivity in some horses.

- **Fertilization:** Apply no N. Apply P and K according to soil test recommendations.
- **Soil pH Range:** 5.8-6.5
- **Approximate Planting Date:** 30-60 days before last killing frost in spring, or 30-45 days before first killing frost in fall.
- **Approximate Harvest Dates:** June, at 1/2 to full bloom, or when about 3/4 of the heads are ripe. Handle as other clover.

Austrian winter pea and field pea

Austrian winter pea and field peas (*Pisum sativum*) are winter annuals used for forage or cover crops. They cross-inoculate with garden peas and vetch.

- **Fertilizer:** Apply no N. Apply P and K according to soil test recommendations.

- **Soil pH Range:** 6.0-6.5
 - **Approximate Planting Dates:** Fall: September to mid-October; Spring: March-April.
 - **Harvesting:**
 - Silage: When barley or other small grain is in soft dough.
 - Hay: When in full bloom. Difficult to cure for hay.
 - Seed: When pods begin to turn brown.
-

Bermudagrass Bermudagrass (*Cynodon dactylon*) is a perennial warm-season grass used for pasture, hay, silage, and turf. Bermudagrass produces most of its biomass during June, July, and August and achieves the greatest forage potential in the southern Piedmont and southern Coastal Plain. It is propagated by sprigs (rhizome and stolon pieces) and seed.

- **Fertilization:** Apply 70 lbs N/A at planting. Apply 175-300 lbs N/A for hay and lower N rates when used as pasture. Apply P and K according to soil test recommendations.
 - **Approximate Planting Dates:** April-June.
 - **Harvesting:**
 - Hay: Cut when 8-12 inches tall before heading, or every 35-45 days.
 - Pasture: Can be continuously stocked if grazed no shorter than 2-3 inches. Rotational stocking is preferred; turn in at 6-8 inches; move cattle at 2-3 inches. Minimize seed production to maintain quality and growth rate. Do not graze during establishment year; cut for hay instead.
-

Birdsfoot trefoil Birdsfoot trefoil (*Lotus cornicalatus*) is a fine-stemmed perennial legume adapted to higher elevations in Virginia and western Maryland and to northern areas of the Mid-Atlantic region. Birdsfoot trefoil is a short-lived perennial that can reseed and is used for hay or pasture. Inoculation is essential since trefoil does not cross-inoculate with other legumes.

- **Fertilization:** Apply no N. Apply P and K according to soil test recommendations.
- **Soil pH Range:** 5.8-6.5
- **Approximate Planting Dates:** March-April or August-September. Should be sown with a grass such as orchardgrass or Kentucky bluegrass.

- **Harvesting:** Harvest for hay when in bloom. Avoid clipping close if extremely dry.
-

**Bluegrass,
Kentucky**

Kentucky bluegrass (*Poa pratensis*) is a low-growing, sod-forming, perennial grass that spreads by underground rhizomes. It is used for permanent pasture and lawns and requires several years to become well established. Kentucky bluegrass provides good early grazing, goes dormant in summer, and revives in fall to again furnish good grazing.

- **Fertilization:** If seeded with white clover, 20 lbs N/A at seeding. Apply P and K according to soil test recommendations.
 - **Soil pH Range:** 6.0-6.5
 - **Approximate Planting Dates:** Late summer or early spring.
-

**Bromegrass,
smooth**

Smooth bromegrass (*Bromus inermis*) is a sod-forming, perennial grass that spreads by underground rhizomes. It is drought-tolerant, and is used for hay and pasture. Historically, smooth bromegrass is not well adapted to some areas of the Mid-Atlantic because of diseases, although newer varieties may be more disease-resistant.

- **Fertilization:** 100-200 lbs N/A. Lower N rates are required when used as pasture in split applications. Apply P and K according to soil test recommendations.
 - **Soil pH Range:** 5.8–6.7
 - **Approximate Planting Dates:** Early spring, or in fall. Companion crops are still used but recent research indicates that they can set back stand establishment. If planted early, fall-seeded bromegrass should not need a small grain companion crop to establish as fall weed competition should be minimal.
 - **Approximate Harvest Dates:** Early bloom stage. Do not graze or cut during stem elongation.
-

**Caucasian
bluestem**

Caucasian bluestem (*Bothriochloa caucasica*) is a warm-season, long-lived, perennial bunch grass that is used primarily for pasture, although it can be used for hay. Caucasian bluestem does not do well on extremely sandy soils or wet soils.

- **Fertilization:** Apply 60-120 lbs N/A in split applications. Apply P and K

according to soil test recommendations.

- **Soil pH Range:** 5.5-6.2
 - **Approximate Planting Date:** After soil temperature reaches 65° F in late May or early June.
 - **Harvesting:**
 - Hay: Harvest in boot stage.
 - Pasture: Maintain in vegetative stage. Loses palatability after seedhead emergence. Tolerates close grazing. Rotational stocking best.
-

**Comfrey,
Quaker
(Russian
comfrey)**

Quaker comfrey (*Symphytum peregrinum*), also called Russian comfrey, is a perennial used for green manure or as forage.

- **Fertilization:** 60 lbs N/A. Apply P and K according to soil test recommendations.
 - **Soil pH Range:** 6.0-6.5
 - **Approximate Planting Date:** Fall or early spring. Root cuttings in rows 3 feet apart in prepared seedbed.
 - **Harvesting:** Cut to a 2 inch stubble when leaves reach a length of 18-24 inches.
-

Crimson clover

Crimson clover (*Trifolium incarnatum*) is an annual legume used for green manure, hay, cover crop, and pasture crop. Inoculation is important. Crimson clover will cross-inoculate with red, alsike, ladino, and white clovers. It is best suited to the southern Coastal Plain and southeastern Piedmont. When seed is allowed to mature and the crop is cut for horse feed, or when horses are allowed to graze the mature crop, the seed capsules enclosing each seed can act as an irritant to the eyes and nasal passages of horses.

- **Fertilization:** Apply no N. Apply P and K according to soil test recommendations.
- **Soil pH Range:** 5.8-6.5
- **Approximate Planting Date:** In the fall, 30-60 days before frost. Plant 20-30 lbs hulled seed alone; 15 lbs in mixtures.
- **Harvesting:** Cut for hay when most advanced heads are beginning to show faded flowers at base.

- **Approximate Harvest Dates:** Hay: May 15-June 1; Seed: June 15-July 1.
For green manure, spray or till 20-30 days before planting succeeding crop.
-

Crownvetch

Crownvetch (*Coronilla varia*) is a perennial with creeping underground roots that is used primarily for erosion control, and stabilization. It has limited potential for pasture and hay use because of limited regrowth after defoliation. Inoculation is important and a specific inoculum is required.

- **Fertilization:** Apply no N. Apply P and K according to soil test recommendations.
 - **Soil pH Range:** 5.5-6.5
 - **Approximate Planting Date:** Late winter or early spring at 5-10 lbs scarified seed.
-

Eastern gamagrass

Eastern gamagrass (*Tripsacum dactyloides*) is a warm season perennial bunch grass that is used primarily for grazing, but is also used for hay, silage, erosion control, and wildlife. It grows in fertile bottomland, swamps, and along stream banks. Seed dormancy is high, so special treatment is needed before planting.

- **Fertilization:** Apply 100-150 lbs N/A/Yr in split applications. Apply P and K according to soil test recommendations.
 - **Soil pH Range:** 5.8-6.5
 - **Approximate Planting Date:** Plant wet, chilled seed after the soil temperature reaches 60 to 65° F. Alternatively, dormant seed can be sown in November-December.
 - **Harvesting:**
 - Hay and silage: Harvest 2-3 times per year in vegetative to early head stages. Can harvest to 5 inches stubble.
 - Pasture: Use rotational stocking; turn in at 18-24 inches, graze to 8 inches residual.
-

Fescue, sheep's

Sheep's fescue (*Festuca ovina*) is a long-lived bunch grass which forms dense turf. It is used in pastures but is seldom seeded. (Commercial seed comes from Europe.) Sheep's fescue does better than most grasses on sandy soils.

- **Fertilization:** 40-60 lbs N/A. Apply P and K according to soil test

recommendations.

- **Soil pH Range:** 5.0-6.2.
 - **Approximate Planting Dates:** August or early fall is best, but may be sown in spring.
-

Fescue, tall

Tall fescue [*Festuca arundinacea* (syn *Lolium arundinaceum*)] is a long-lived, tufted, deep-rooted perennial grass which produces most of its biomass in early spring and late fall. Tall fescue is used for pasture, hay, and turf, and is also widely used for winter grazing. Most existing tall fescue stands are *endophyte-infected*, which means they are contaminated with a fungal endophyte that improves the heat and drought tolerance of the plant, but induces fescue toxicosis in cattle. *Endophyte-free* varieties are less hardy than endophyte-infected tall fescue and require more careful management. *Endophyte-enhanced* varieties are infected with a special endophyte fungus that does not produce the toxin that causes animal problems but still improves heat and drought tolerance.

- **Fertilization:**
 - Establishment: 40 lbs N/A.
 - Pasture topdressing: For winter grazing, apply 60-75 lbs N/A in mid-August.
 - Hay topdressing: 120-200 lbs N/A.
 - Apply P and K according to soil test recommendations.
 - **Soil pH Range:** 5.6-6.2
 - **Approximate Planting Dates:** Early fall or spring.
 - **Harvesting:**
 - Hay: First cut when heads begin to emerge. Stems and seedheads of endophyte-infected fescue are highly toxic, especially to pregnant mares, and can significantly reduce animal gains during the heat and droughts in summer. To prevent endophyte-free fields or endophyte-enhanced fields from becoming infected, mow fields and surrounding areas to prevent seed formation in any endophyte-infected fescue plants that may be present.
 - Seed: When field takes on yellowish-brown cast and heads droop.
 - Pasture: Tolerant of continuous stocking. With rotational stocking, turn in at 8 inches; remove cattle at 2-3 inches. Keep vegetative to reduce potential problems with endophyte.
-

**Lespedeza
bicolor**

Lespedeza bicolor (*Lespedeza bicolor*) is a bushy perennial shrub that is used primarily as food for game birds and for erosion control. It is not adapted to high altitudes because the seed will not ripen in short season areas, and it is not adapted to wet areas.

- **Fertilization:** Apply no N. Apply P and K according to soil test recommendations.
 - **Soil pH Range:** 5.5-6.2.
 - **Approximate Planting Date:** In spring after frost.
-

**Lespedeza,
Korean and
Kobe**

Korean (*Lespedeza stipulacea* Maxim) and Kobe (*Lespedeza striata* var Kobe) lespedezas are warm-season reseeding annual legumes used for hay, pasture, and wildlife cover that are tolerant of acidity and low soil P. They are killed by frost and furnish poor winter cover. Seed in mixtures with grasses or other legumes; or, if seeded alone, use winter cover crop. They may not reseed above 2,500' elevation. Korean is adapted to all areas of Mid-Atlantic, and Kobe is adapted to southeastern sections of Virginia. They cross-inoculate with perennial lespedezas, peanuts, and cowpeas.

- **Fertilization:** At seeding, apply no N. Apply P and K according to soil test recommendations.
 - **Soil pH Range:** 5.5-6.2
 - **Approximate Planting Date:** February and March.
 - **Harvesting:**
 - Hay: Early bloom stage
 - Seed: Combine in fall when ripe
 - **Approximate Harvest Dates:** Hay: August 1-September 1; Seed: September 15-November 1
-

**Lespedeza,
Sericea**

Sericea lespedeza (*Lespedeza cuneata*) is a warm-season, drought tolerant perennial with a growth habit similar to alfalfa. It is used for erosion control, hay, pasture, and cover for wildlife, and is very tolerant of acid soil and low fertility. Sericea cross-inoculates with annual lespedezas, cowpeas, and peanuts.

- **Fertilization:** Apply no N. Apply P and K according to soil test recommendations.

- **Soil pH Range:** 5.0-6.2.
 - **Approximate Planting Date:**
 - Unhulled seed: Late fall or early spring.
 - Scarified seed: March or April.
 - **Harvesting:**
 - Hay: When plants are about 15-24 inches tall. High tannin levels drop when harvested for hay, improving palatability and digestibility.
 - Seed: Direct combined. Second growth produces seed more uniformly and is easier to thresh than first crop, but the yield of the first crop is usually higher.
 - Pasture: Begin grazing at 8-10 inches. Do not graze lower than 4 inches.
 - **Approximate Harvest Dates:** Hay: June - July; Seed: August – September.
-

Matua prairiegrass

Matua prairie grass (*Bromus willdenowii*) is a cool-season, short-lived perennial grass used for hay, greenchop, or silage. It can be used for dairy or beef pastures under rotational stocking management, but is not suited for continuous grazing.

- **Fertilization:** Apply 40 lbs N/A at seeding. For high level of production, apply 50-60 lbs N/A following mechanical harvest or 30-40 lbs N/A following each grazing. Apply P and K according to soil test recommendations.
 - **Soil pH Range:** 6.0-7.0.
 - **Approximate Planting Date:** May be seeded in the fall or spring when the soil temperatures are at least 55° F. No-till or conventional planting methods may be used.
 - **Harvesting:** Mechanical harvest for hay or grazing should begin at the boot stage for best quality, yield, and longevity. A regrowth/rest period of 30-42 days depending on the season is essential. One regrowth per year must be allowed to set seed to maintain the stand.
-

Millet, foxtail

Foxtail millet (*Setaria italica*) is an annual that is used for supplemental pasture and hay crop, for a nurse crop for late spring and for early summer forage seedings. It is necessary to smother the crop prior to late summer no-till forage seedings. Foxtail millet has lower yield and regrowth than pearl millet.

- **Fertilization:** Apply 60-80 lbs N/A. Apply P and K according to soil test

recommendations.

- **Soil pH Range:** 5.8-6.2
 - **Approximate Planting Date:** May 1-July 1.
 - **Harvesting:** Cut for hay at seedhead emergence. Do not feed to horses.
-

Millet, pearl

Pearl millet (*Pennisetum glaucum*) is an annual that is used for supplemental pasture, hay crop, and green chop. It regrows after cutting and grazing.

- **Fertilization:** Apply 60-80 lbs N/A. Apply P and K according to soil test recommendations at seeding. Apply 40-60 lbs N/A after each cutting.
 - **Soil pH Range:** 5.5-6.5
 - **Approximate Planting Date:** May 1-July 1.
 - **Harvesting:**
 - Hay: Cut when heads begin to emerge from boot or at 30-40 inches.
 - Pasture: Requires high stocking rate, preferably with rotational stocking.
 - **Approximate First Harvest Date:** Early to mid-July.
-

Orchardgrass

Orchardgrass (*Dactylis glomerata*) is a long-lived, deep-rooted perennial bunch grass used for pasture, hay, and silage.

- **Fertilization:**
 - Establishment: When seeded alone: 40-50 lbs N/A.
 - Maintenance (hay): 120-200 lbs N/A split 50:50 between early spring and after first cutting.
 - When seeded with clover: Reduce N rate to 20 lbs/A. No N is needed for maintenance where there is more than 35% clover.
 - Apply P and K according to soil test recommendations.
- **Soil pH Range:** 5.8-6.2
- **Approximate Planting Date:** In the Coastal Plain, seed after the first good rain in September up to October 15, or during February or early March. In the Piedmont, Ridge and Valley, and Appalachian Plateau, seed after the first good rain in August up to September 15, or from March to mid-April.

- **Harvesting:**
 - Hay and silage: Cut in boot to early head stage.
 - Pasture: Do not graze below 3 inches. Rotational stocking with 1-4 day grazing periods is best.
 - **Approximate First Harvest Dates:** Hay: May - June; Seed: June - July.
-

Red clover

Red clover (*Trifolium pratense*) is a short-lived perennial that often behaves as a biennial. Used for hay, pasture, silage, and commercial seed production. Inoculation is important. Red clover cross-inoculates with alsike, crimson, ladino, and white clovers.

- **Fertilization:** Apply no N. Apply P and K according to soil test recommendations. Lower amounts needed when used as pasture.
 - **Soil pH Range:** 5.8-6.5
 - **Approximate Planting Date:** 45 days before last killing frost in spring, or 30 days before first killing frost in fall.
 - **Harvesting:**
 - Hay: 1/4-1/3-bloom stage. Early harvesting for hay favors good seed yield by second crop.
 - Seed: Cut with combine when heads have turned brown, flowers and stalks are deep yellow, and seeds have begun to show a distinct violet color. Will shatter badly if cut later.
 - **Approximate First Harvest Dates:** Hay: June; Seed: August-September.
-

Redtop

Redtop (*Agrostis alba*), also known as creeping bentgrass or redtop bent, is a perennial that produces numerous stems from a well-developed base. Used primarily for erosion control and soil stabilization.

- **Fertilization:** Apply 40-60 lbs N/A/Yr. Apply P and K according to soil test recommendations.
 - **Soil pH Range:** 5.8-6.2
 - **Approximate Planting Date:** August and September. May be seeded in spring.
 - **Harvesting:** For hay, shortly before full bloom.
-

**Reed
canarygrass**

Reed canarygrass (*Phalaris arundinacea*) is a tall, coarse, sod-forming perennial cool-season grass which is used for hay, pasture, silage, and conservation cover in wet areas and in areas irrigated for disposal of liquid wastes. It tolerates wet soils, yet is more drought-tolerant than many other cool-season plants.

- **Fertilization:**
 - Establishment: 50 lbs N/A.
 - Maintenance (pasture): 0-60 lbs N/A.
 - Maintenance (hay): 20-200 lbs N split 50:50 between early spring and after first cutting.
 - When seeded with clover: N rate should be reduced to 20 lbs or less. For maintenance where there is more than 35% clover, no nitrogen is needed. If the stand becomes non-competitive with weeds or other species, increase the N rate to strengthen the grass's competitiveness.
 - Apply P and K according to soil test recommendations.
 - **Soil pH Range:** 5.8-6.2
 - **Approximate Planting Date:** Early fall (requires a full six weeks before first frost) or spring. Often slow to establish.
 - **Harvesting:** First cut when heads begin to emerge.
 - **Approximate Harvest Dates:** Hay: May - June.
-

**Ryegrass,
annual and
perennial**

Annual (or Italian) ryegrass (*Lolium multiflorum*) is a bunchgrass that is used for hay and pasture, especially as a supplementary pasture mixed with crimson clover and/or small grain. It tolerates close, continuous stocking. It is also used for a green manure, winter turf, and over-seeding bermudagrass. Perennial (or English) ryegrass (*Lolium perenne*) is similar to annual ryegrass in use and adaptability. Special varieties are adapted for turf purposes. Perennial ryegrass is also used for pasture, where it is high yielding during the first year, but has decreased yields in subsequent years due to poor persistence.

- **Fertilization:** For pasture, 20 lbs N/A and 50-70 lbs N topdressed in spring. Apply P and K according to soil test recommendations.
- **Soil pH Range:** 5.8-6.2
- **Approximate Planting Date:** August 15 to November 15. Use the earlier seeding date for Northern Piedmont and west of the Blue Ridge, including WV and PA.

**Sorghum,
forage**

Forage sorghum (*Sorghum bicolor*) is an annual very similar to corn in the vegetative stage that is used for silage, hay, grazing.

- **Fertilization:** Apply 60-80 lbs N/A. Apply P and K according to soil test recommendations.
 - **Approximate Planting Date:** 1-2 weeks after corn. Soil needs to be warm (at least 60° F).
 - **Harvesting:**
 - For hay or wilted silage: Cut no later than early head emergence.
 - For direct ensiling: Cut in dough stage.
-

**Sudangrass and
sorghum-
sudangrass
hybrid**

Sudangrass (*Sorghum sudanense*) and sorghum-sudangrass hybrid are annuals that are used for hay, silage, and supplemental pasture.

- **Fertilization:** Apply 60-80 lbs N/A plus 40-60 lbs N after each cutting. Apply P and K according to soil test recommendations.
- **Soil pH Range:** 5.8-6.2
- **Approximate Planting Date:** Two weeks after corn.
- **Harvesting:**
 - Hay: Cut just as heads emerge.
 - Silage: Cut when grain is in dough stage, or as heads emerge and wilt.
 - Do not graze or harvest for green chop until plants are 24 to 30 inches tall to reduce danger of prussic acid poisoning.
- **Approximate Harvest Dates:** July (both hay and silage).

Note: Johnsongrass (*Sorghum halepense*) is a coarse, tall-growing perennial grass of the sorghum group that spreads by seed and strong underground stems. It was used as hay and pasture in some of the southern states, but is considered a serious pest in crop fields in most of the eastern U.S. Johnsongrass is considered a **noxious weed** in many states and is prohibited as a seed contaminant. It is also against the law to seed this plant. It spreads easily from seed when abandoned or when roadside stands are allowed to mature.

Sweet clover

Sweet clover [*Melilotus alba* (white flowered); *Melilotus officinalis* (yellow flowered)] is an erect biennial that is used for pasture, hay, and green manure. Inoculation is important, and the sweet clovers cross-inoculate with alfalfa and bur clover.

- **Fertilization:** Apply no N. Apply P and K according to soil test

recommendations.

- **Soil pH Range:** 6.5-7.0
 - **Approximate Planting Date:** February, using unhulled seed. Use scarified seed in late March or April. Plant in grain with drill in February or March, or sow on frozen ground.
 - **Harvesting:** For hay, cut in bud stage before any bloom appears.
 - **Approximate Harvest Dates:** Hay, May 10-June 1
-

Switchgrass

Switchgrass (*Panicum virgatum*) is a native, warm-season, sod-forming, perennial tall grass that is used for summer pasture or hay. Switchgrass will not persist under close or frequent grazing.

- **Fertilization:** Generally has a low fertility requirement. At establishment, apply P and K according to soil test recommendations. Apply 40-60 lbs N/A annually if legumes are not present.
 - **Soil pH Range:** 5.5-6.5
 - **Approximate Planting Date:** May 15-July 15 using 6-8 lbs pure live seed.
 - **Harvesting:**
 - Hay: Cut prior to seed head emergence.
 - Pasture: Begin grazing when 18 to 24 inches tall. Do not graze below 8 inches.
 - **Approximate First Harvest Dates:** July 15- August 1.
-

Tall meadow oatgrass

Tall meadow oatgrass (*Arrhenatherum elatius*) is a perennial bunchgrass that is used for hay and pasture. Tall meadow oatgrass makes early spring growth but very little aftermath growth.

- **Fertilization:** Apply 40-60 lbs N/A. Apply P and K according to soil test recommendations.
- **Soil pH Range:** 5.8-6.2
- **Approximate Planting Date:** Late summer or fall using 15-20 lbs alone or 10-12 lbs in mixtures.
- **Harvesting:** For hay, cut at early heading stage.

- **Approximate Harvest Dates:** Hay, May 15 – June 1
-

Timothy

Timothy (*Phleum pratense*) is a perennial, cool-season, semi-bunch grass. It is primarily used for hay, and is best adapted to the northern United States, but does fairly well in northern Piedmont, Ridge and Valley, and the Appalachian Plateau. Timothy makes very little regrowth after spring cutting when compared to orchardgrass or tall fescue. It is usually seeded in mixtures with clovers or alfalfa.

- **Fertilization:** Apply 40-60 lbs N/A. Apply P and K according to soil test recommendations.
 - **Soil pH Range:** 5.8-6.2
 - **Approximate Planting Date:** Spring or fall.
 - **Approximate Harvest Dates:** Hay: June 1-July 1
-

Vetch, hairy

Hairy vetch (*Vicia villosa*; sometimes called winter vetch) is an annual semi-vining legume with 3-5' long stem. Used for hay, pasture and winter cover. Because of the hardness of the seed and its size, it often becomes a weed in small grain crops that follow. Inoculation is important. Vetch cross-inoculates with garden peas and field peas.

- **Fertilization:** Apply no N. Apply P and K according to soil test recommendations.
 - **Soil pH Range:** 6.0-6.5
 - **Approximate Planting Date:** August 1 - November 1.
 - **Harvesting:**
 - Hay: When seeds in lower half of the plants are half developed.
 - Seed: Cut when first pods are well developed.
 - **Approximate Harvest Dates:** Hay: May 1-June 1.
-

White clover, common

Common white clover (*Trifolium repens*) is a low growing, short-lived, perennial legume that is used for pastures and tolerates close, continuous grazing. White clover cross-inoculates with alsike, crimson, ladino, and red clover.

- **Fertilization:** With bluegrass or other cool-season grasses at seeding, apply 0-20 lbs N/A. Apply P and K according to soil test recommendations.
 - **Soil pH Range:** 5.8-6.5
 - **Approximate Planting Date:** 45 days before last killing frost in spring or 30 days before first killing frost in fall.
-

**White clover,
ladino**

Ladino white clover (*Trifolium repens latum*) is a giant variety of white clover resembling white clover in every respect except size. It is used primarily for pasture with tall growing grasses such as orchardgrass. It is less persistent and grazing-tolerant than white clover. Inoculation is important. Ladino cross-inoculates with alsike, crimson, ladino, and red clover

- **Fertilization:** Alone at seeding or topdressing, apply no N. Apply P and K according to soil test recommendations.
 - **Soil pH Range:** 6.0-6.5.
 - **Approximate Planting Date:** 30-60 days before the average date of the first killing frost in fall or 30-45 days before the average date of the last killing frost in spring. Fall seedings are preferred.
-

Links to information on turfgrass, fruit, and vegetable production

Information on **turfgrass** production can be found in:

- The Virginia Tech Agronomy Handbook, Part III, available at <http://www.ext.vt.edu/pubs/agronomy/part3.pdf>

Information on **vegetable** and **fruit** production can be found in:

- Nutrient Management for Tree Fruits and Small Fruits, available at <http://www.agnr.umd.edu/users/agron/nutrient/Pubs/NM-5.pdf>
 - The Maryland Commercial Vegetable Production Recommendations, available at: <http://www.agnr.umd.edu/MCE/Publications/Publication.cfm?ID=674&cat=C>
 - The Pennsylvania Tree Fruit Production Guide, available at: <http://tfpg.cas.psu.edu/default.htm>
-

References cited

Alley, M.M., D.E. Brann, E.L. Stromberg, E.S. Hagood, A. Herbert, E.C. Jones, and W.K. Griffith. 1993. Intensive soft red winter wheat production: a management guide. Virginia Tech Cooperative Extension Publication 424-803.

Brann, D.E., A.O. Abaye, and P.R. Peterson. Crop Description, Part 1. *In* Brann, D.E., D.L. Holshouser, and G.L. Mullins. Virginia Tech Agronomy Handbook. Virginia Tech Cooperative Extension Publication 424-100. Available on-line at: <http://www.ext.vt.edu/pubs/agronomy/>

References for additional information

Barnes, R.F., C.R. Nelson, M. Collins, and K.J. Moore (eds). 2003. Forages, an introduction to grassland agriculture, 6th Edition. Blackwell Publishing, Ames, IA.

Hoelt, R.G., Nafziger, E. D., Johnson, R.R., and Aldrich, S.R. 2000. Modern corn and soybean production, 1st edition. MCSP Publications. Champaign, IL.

Maynard, D.N., and G. J. Hochmuth. 1997. Knott's handbook for vegetable growers, 4th edition. John Wiley and Sons.

Westwood, M.N. 1993. Temperate zone pomology, 3rd edition. Timber Press, Portland, OR.

Chapter 6. Soil Management

Sjoerd Willem Duiker

Department of Crop and Soil Sciences, Penn State University

Table of Contents

Introduction.....	128
The importance of soil management.....	128
Soil quality.....	128
Defining soil quality.....	128
Soil quality indicators.....	128
Soil erosion.....	129
Effects of erosion.....	129
Water erosion.....	130
The Revised Universal Soil Loss Equation.....	131
Rainfall erosivity.....	131
Soil erodibility.....	132
Tillage erosion.....	132
Tolerable soil loss levels.....	133
Controlling soil erosion.....	134
Controlling erosion with cropping and management practices.....	134
Controlling erosion by changing slope length and steepness.....	135
Erosion control practices that help protect water quality.....	135
Soil compaction.....	136
Yield loss.....	136
Other effects of compaction.....	137
Causes of compaction.....	137
Surface compaction.....	138
Subsoil compaction.....	139
Plow pans.....	140
Natural compaction.....	140
Controlling compaction.....	140
Avoiding soil compaction.....	140
Choosing equipment for remediating compaction.....	141
Using cover crops to ameliorate compaction.....	142
Residue management and conservation tillage.....	144
Crop residue management.....	144
Conservation tillage.....	144
Tillage system definitions.....	145
Tillage systems in the Mid-Atlantic.....	146
No-tillage.....	147
Cover crops.....	148
References cited.....	150

Introduction

The importance of soil management

The quality of many soils in the Mid-Atlantic region can be improved with good management. Some practices that are part of nutrient management plans may have unintended consequences that degrade instead of improve soil quality. For example, it is often recommended that manure be incorporated with tillage. However, tillage exposes the soil to erosion, reduces organic matter content and can increase runoff. Facilities that store large amounts of manure may require heavy manure spreading equipment, and often have a smaller time window for spreading, both of which increase the risk of soil compaction. If nutrient management specialists can design plans that meet soil conservation and soil quality considerations as well as nutrient management requirements, they will do a great service to agricultural producers, other citizens, and the quality of natural resources in the Mid-Atlantic.

Soil quality

Defining soil quality

Soil quality is defined as “*the capacity of a soil to function within ecosystem boundaries to sustain biological productivity, maintain environmental health, and promote plant and animal health*” (Doran and Parkin, 1994). Soil quality became a widely accepted concept after a symposium was held by the Soil Science Society of America and the American Society of Agronomy in 1992 (Doran et al, 1994). There is widespread concern among soil scientists that the quality of many soils in the U.S. has declined significantly since the beginning of cultivation.

Soil quality indicators

Soil scientists are working to develop quantitative indicators of soil quality, similar to those used to measure air and water quality. The following minimum dataset has been proposed by Doran and Parkin (1996) for soil quality measurement:

- texture
- depth of soil
- infiltration
- bulk density
- water holding capacity
- soil organic matter
- pH
- electrical conductivity

- microbial biomass C and N
- potentially mineralizable N
- soil respiration

Collecting such data requires a substantial investment in time and resources, especially because some of the soil quality parameters change over time and with management. Therefore, a less scientific, but nonetheless valuable, approach has been to use readily observable, but subjective, ratings of soil quality. For example, the Pennsylvania Soil Quality Assessment scorecard (available at <http://pubs.cas.psu.edu/FreePubs/pdfs/uc170.pdf>) has been developed as a tool to rate soil quality quickly in the field. This scorecard gives guidance to judge soil structure, compaction, water movement, erosion, and different biological indicators. It can be used to evaluate and compare fields and then suggest changes to improve or maintain soil quality.

Soil erosion

Effects of erosion

In the Mid-Atlantic region, soil erosion is one of the major contributors to degradation of water quality. It is closely linked to phosphorus pollution because most phosphorus transported into the Chesapeake Bay is attached to soil particles. In practice, this means that soil erosion control practices will also decrease phosphorus movement in the landscape. Soil erosion also causes increased turbidity and sedimentation in the Bay. Other effects of soil erosion on the Chesapeake Bay and associated waterways are:

- Increased need for channel dredging.
- Adverse impacts on the recovery of underwater grass beds because the sediment reduces the amount of light reaching plants.
- Benthic (bottom-dwelling) organisms suffer increased mortality and reduced reproduction.
- Fish may be affected as increased sediment affects their feeding, clogs gill tissues, and smothers eggs.
- Siltation can alter the habitat of aquatic organisms.
- Increased turbidity may change the abundance of plankton, a prey which is important for larval and juvenile fish.
- Phosphorus is carried with the sediment, contributing to eutrophication.

Soil erosion also seriously reduces soil quality. The loss of productive topsoil by erosion exposes the subsoil, which usually is less productive, and has undesirable physical characteristics for field work and plant growth. Degraded soils are visible throughout the undulating parts of the Mid-Atlantic region in higher spots in fields where clay knobs or stone outcrops come to the surface. Crop establishment is poor on these knobs because of coarse

seedbeds and poor seed-to-soil contact. Drought stress because of reduced water-holding capacity is also common on these knobs and outcrops.

Water erosion

Soil erosion can be caused by wind, water, or tillage. Water and tillage erosion are of most concern in the Mid-Atlantic region.

There are four types of water erosion:

- *Inter-rill erosion*: the movement of soil by rain splash and its transport by thin surface flow. The erosive capacity of inter-rill surface flow is increased by turbulence generated by raindrop impact.
- *Rill erosion*: erosion by concentrated flow in small rivulets.
- *Gully erosion*: erosion by runoff scouring large channels (deeper than 1 foot).
- *Streambank erosion*: erosion by rivers or streams cutting into banks.

The term *sheet erosion* is still frequently used, but omits the concept of rainsplash (Figure 6.1), and conveys the erroneous concept that runoff commonly occurs as a uniform sheet.

Figure 6.1. Raindrop impact on bare soil initiates the erosion process. (Photo courtesy of USDA-NRCS)

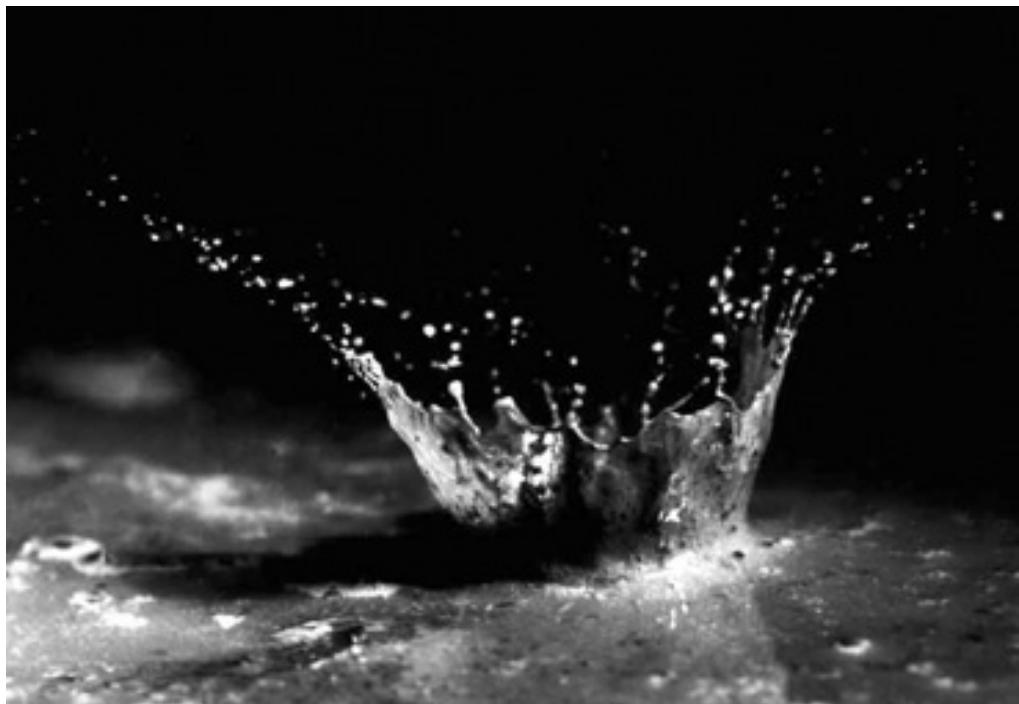

**The Revised
Universal Soil
Loss Equation**

The Natural Resources Conservation Service (NRCS) uses the *Revised Universal Soil Loss Equation* (RUSLE) to calculate soil loss by erosion as a function of 5 factors:

$$A = R \times K \times LS \times C \times P$$

Where:

A = annual soil loss (tons/A/yr)

R = erosivity of rainfall

K = erodibility of the soil

LS = slope length/steepness

C = cropping and management factors

P = erosion control practices

**Rainfall
erosivity**

The impact of raindrops on the soil surface is the beginning, and most important part, of the erosion process. The extent of erosion caused by rainfall (*erosivity*) depends on the size and velocity of raindrops and the amount of precipitation. Gentle, drizzly rain is not very erosive, whereas fierce thunderstorms and hurricanes are very erosive. High-intensity storms produce larger drops that fall faster than those of low-intensity storms and therefore have greater potential to destroy aggregates and dislodge particles from the soil matrix. Although the same total amount of rain may fall, a short, high-intensity rainfall event causes much more erosion than a long, low-intensity storm.

The erosivity of annual precipitation is calculated from the intensity of rainfall and the total energy of storms. Erosivity increases from the north to the south in the Mid-Atlantic region because convectional storms (usually taking place as thunderstorms in summer) are more common in the southern U.S. Most erosive precipitation events usually occur in the late summer and early fall (Figure 6.2). Soils that are bare during this period are under extreme risk of soil erosion. Bare soil (especially if planted to wide-spaced crops such as corn) is also extremely vulnerable to erosion before canopy closure in the spring.

Figure 6.2. An example of rainfall erosivity in the eastern part of the Chesapeake Bay watershed (calculated from Renard et al., 1997). Erosive storms are most frequent in the late summer/early fall.

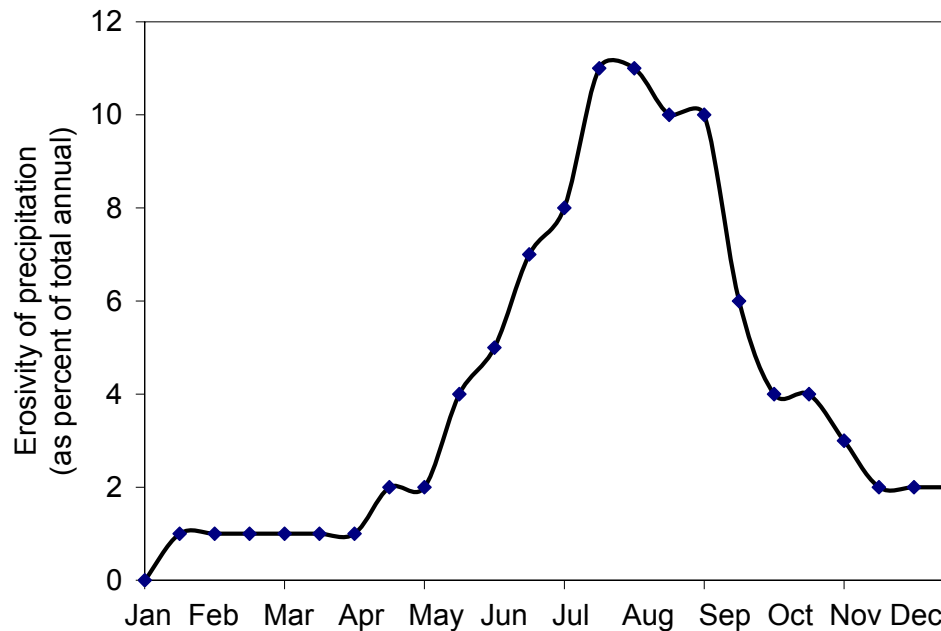

Soil erodibility Soils differ in their susceptibility to erosion (*erodibility*) depending on natural and human factors. Erodibility is influenced by many factors, some of which vary during the year and/or vary with soil management:

- The erodibility of a soil increases with a decrease in aggregate stability. Clay and organic matter help improve aggregate stability and reduce erodibility.
- Living or dead roots also increase aggregate stability and decrease erodibility.
- Erodibility decreases with an increase of large sand grains and rock fragments because these large particles are not easily moved with water.

Soil conservation personnel use standard erodibility values published for each soil series in a particular county.

Tillage erosion Tillage erosion is a form of erosion that is receiving increased attention. Tillage erosion is limited to movement of soil within a field. It causes topsoil to be removed from the high points of fields and exposes subsoil. Research suggests that the total amount of soil that is moved with tillage erosion exceeds that of water erosion. Tillage erosion is probably the main cause of increased yield variability due to in-field soil movement.

Tilling up-and-down the slope causes more soil to move downslope than upslope (Figure 6.3). Tillage along the contour also moves soil downslope. More soil is moved if a moldboard throws soil downslope, which is usually preferred because better inversion is obtained this way.

Figure 6.3. Three causes of erosion resulting from tilling soils on slopes. Reprinted from Magdoff and van Es, 2000, with permission from the Sustainable Agriculture Network (SAN). (For more information about sustainable agriculture, see www.sare.org.)

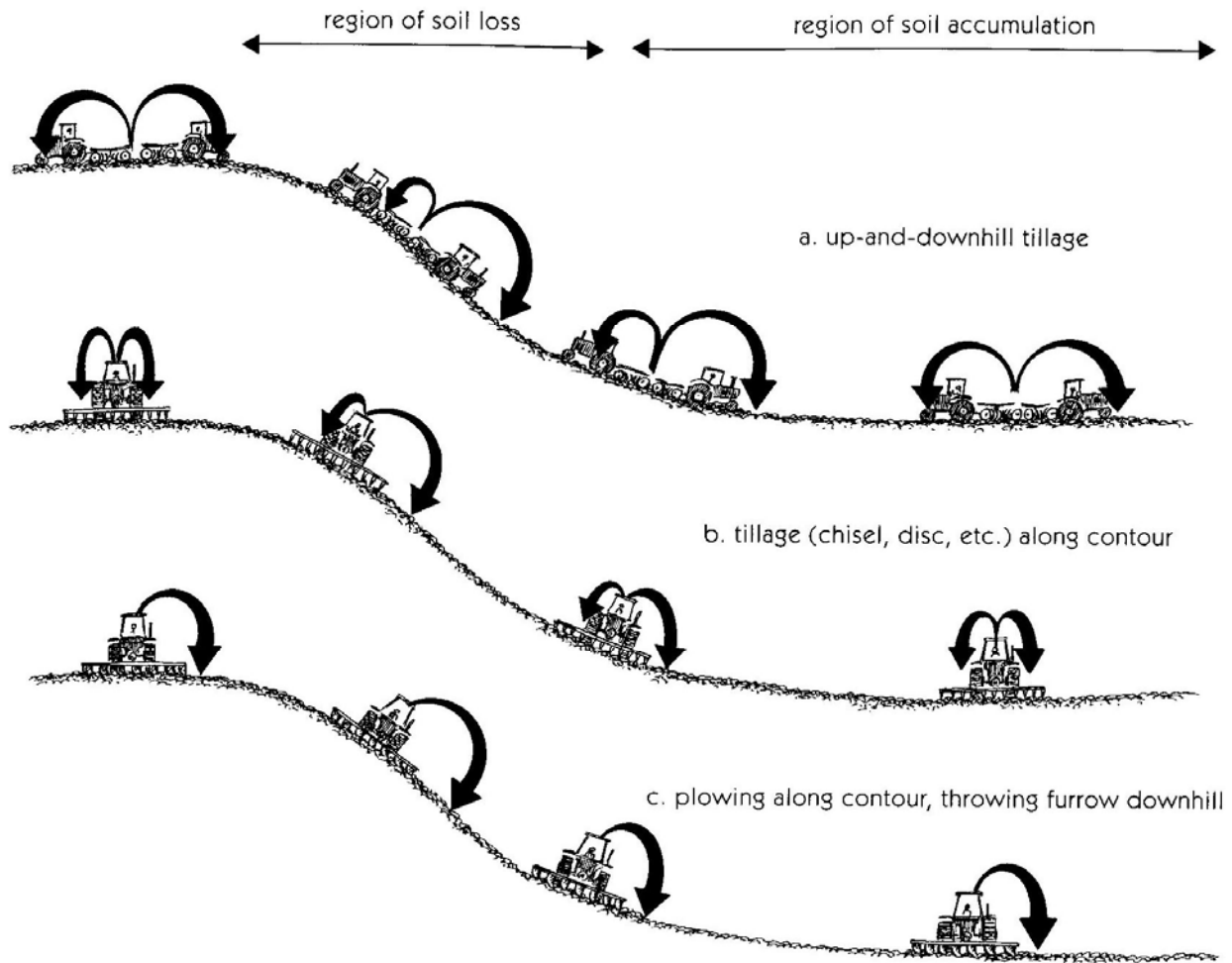

Tolerable soil loss levels

Since soils are continuously formed from parent material, it is commonly accepted that a low level of erosion will not compromise soil productivity. NRCS personnel use tolerable soil loss levels (T), which vary per soil type, to indicate the maximum rate of soil erosion that can be allowed while still permitting crop productivity to be sustained indefinitely. Levels of T are a function of root development, gully prevention, on-field sediment problems, seeding losses, reduction of soil organic matter, and loss of plant nutrients. The level of T varies from 3 to 5 tons/acre/year for most soils in the Mid-

Atlantic region. Deep soils with subsoil characteristics favorable for plant growth have greater T levels than soils with shallow root zones or high percentages of shale at the surface.

Controlling soil erosion

Controlling erosion with cropping and management practices

The two types of water erosion that can be controlled by soil management practices are inter-rill and rill erosion. Engineering structures such as grassed waterways and streambank reinforcement are usually needed to limit other types of water erosion.

Cropping and management practices to control erosion include previous management and cropping, the protection offered the soil surface by vegetative canopy, and surface cover and surface roughness. Generally, the most important crop management practices that will help decrease erosion are:

- maintaining crop residue cover above 30% until crop canopy closure
- alternating summer crops with winter crops and perennial crops
- using cover crops during periods when the soil would have insufficient residue

Additional erosion protection is provided by contour farming and contour strip cropping:

- **Contour farming** implies that crops are planted nearly on the contour. The benefit of this practice is greatest on moderate slopes (2-6%) when crops are planted in tilled soil where ridge height is 2-3 inches. However, even with no-till, contour farming can reduce erosion if residue cover is marginal and ridge height is 2 inches or more.
- **Contour strip-cropping** involves alternating strips with high-residue cover or perennial crops with strips with low residue cover. The strips should be laid out close to the contour, something that is not always possible in rolling landscapes. Strip width is usually between 75 and 120 feet. The soil that erodes from the bare or low residue strips is deposited in the strips with high residue or dense vegetation because runoff velocity is decreased. This practice is most useful if the soil is tilled or if the soil is left bare during part of the year in no-till. In today's cropping systems, the difference in cover between strips is frequently minimal, which reduces the effectiveness of this practice.

If high residue cover (greater than 30% at all times) is maintained in no-till

systems, contour farming and contour strip-cropping are usually not necessary.

Controlling erosion by changing slope length and steepness

As slope length and steepness increase, runoff and soil loss also increase. Slope steepness can be changed by the construction of level terraces as is common in Southeast Asia. However, in the United States it is relatively uncommon to change slope steepness with management practices.

Slope length can be changed by installing *terraces* and *diversions* that divert runoff:

- **Terraces** are cross-slope channels that control erosion on cropland and are built so that crops can be grown on the terrace.
 - *Storage terraces* store water until it can be absorbed by the soil or released to stable outlet channels or through underground outlets. Storage terraces are usually designed to drain completely in 48 hours to avoid waterlogging within the terrace.
 - *Gradient terraces* are channels designed almost perpendicular to the natural field slope that collect runoff water and carry it to a stable outlet like a waterway.
 - **Diversions** are similar to terraces, except that they are permanently vegetated with grass. They are used on steeper slopes where a terrace would be too expensive or difficult to build, maintain, or farm. They can also be used to protect barnyards or farmsteads from runoff.
-

Erosion control practices that help protect water quality

There are other erosion control practices that help maintain water quality but are not immediately relevant to maintain soil productivity on working cropland. The following practices are very helpful in reducing sediment and nutrient load in surface waters even though they do not directly improve soil quality:

- **Contour buffer strips:** permanently vegetated strips located between larger crop strips on sloping land.
- **Field borders:** bands or strips of permanent vegetation at the edge of a field.
- **Filter strips:** strips or areas of permanent vegetation used to reduce sediment, organic materials, nutrients, pesticides, and other contaminants from runoff.

- **Riparian forest buffers:** areas of trees and/or shrubs along streams, lakes, ponds, or wetlands.
 - **Vegetative barriers:** narrow permanent strips of stiff-stemmed, tall, dense perennial vegetation established in parallel rows perpendicular to the dominant field slope.
 - **Grassed waterways:** natural or constructed swales where water usually concentrates as it runs off a field.
 - **Streambank protection:** structures such as fences and stable crossings to keep livestock out of the streams as well as streambank stabilization with rocks, grass, trees, shrubs, riprap, or gabions.
-

Soil compaction

Yield loss

Soil compaction is the reduction of soil volume due to external factors. The risk of soil compaction is greater today than in the past due to an increase in the size of farm equipment.

Soil compaction reduces soil productivity. Research in tilled soils showed average first-year yield losses due to compaction of approximately 15% (Figure 6.4). Yield loss in the first year after compaction is mostly due to residual effects of surface compaction. In this summary of many studies in different countries, yield losses decreased to approximately 3% by 10 years after the compaction event (in the absence of re-compaction). The final yield loss was assumed to be due to subsoil compaction and can be considered permanent.

Figure 6.4. Relative crop yield on compacted soil compared to non-compacted soil with moldboard plowing. The fields were wheeled four times with 10-ton axle load, 40 psi (pounds per square inch) inflated tires. The letters a, b, and c indicate yield losses due to compaction of the topsoil, upper part of the subsoil, and lower subsoil (Hakansson and Reeder, 1994).

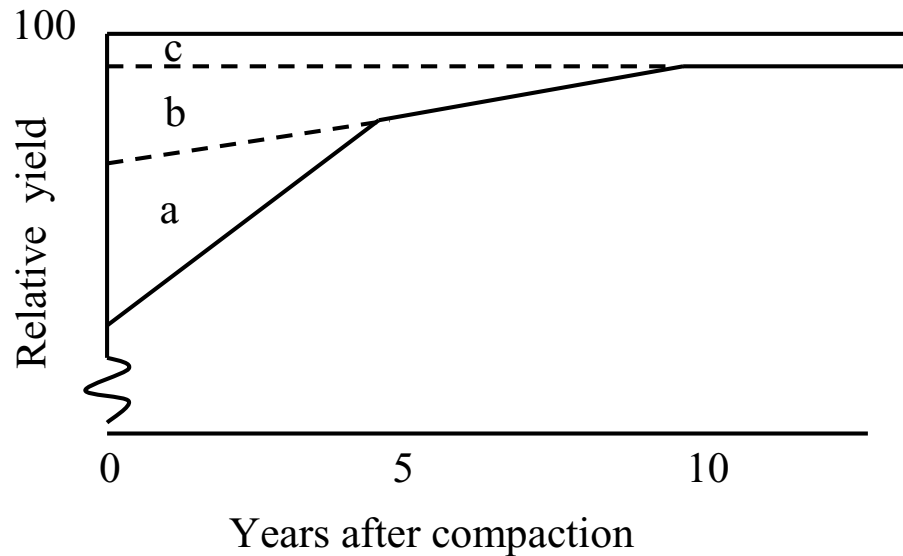

Other effects of compaction

Soil compaction also reduces both soil quality and environmental quality:

- Compacted soil is dense and has low porosity. Compaction preferentially compresses large pores, which are very important for water and air movement in the soil. Infiltration is then reduced and erosion is increased.
- Compaction causes the penetration resistance of the soil to increase. There is little root penetration in soil above 300 psi, except if there are cracks and macropores in the soil that can be followed by plant roots. More energy is expended when tilling compacted soil.
- Compacted soil is a harsher environment for soil organisms (especially earthworms) to live in.
- Compaction affects nutrient uptake. Denitrification rates can increase in compacted soil due to limited aeration. Manure ammonia volatilization losses have been found to increase when liquid manure is surface applied to compacted soils because of reduced infiltration. Phosphorus and potassium uptake can be reduced if root growth is inhibited.

Causes of compaction

Compaction is caused by wheel or foot traffic on the soil and by soil tillage. Soil is most compactable at a moisture content approximating field capacity

(for example, 24 hours after a soaking rain). If the soil is saturated, it is difficult to compact because water fills pores. Rutting and slipping during trafficking of saturated soil, however, can also destroy soil structure.

Surface compaction

Surface compaction (Figure 6.5) is caused by contact pressure (expressed in psi). A pick-up truck tire can cause as much surface compaction as a manure spreader at the same contact pressure. Contact pressure is approximately similar to tire pressure in flexible tires.

Figure 6.5. Surface compaction is caused by high contact pressures. Using flotation tires instead of narrow tires reduces surface contact pressure, but does not reduce subsoil compaction.

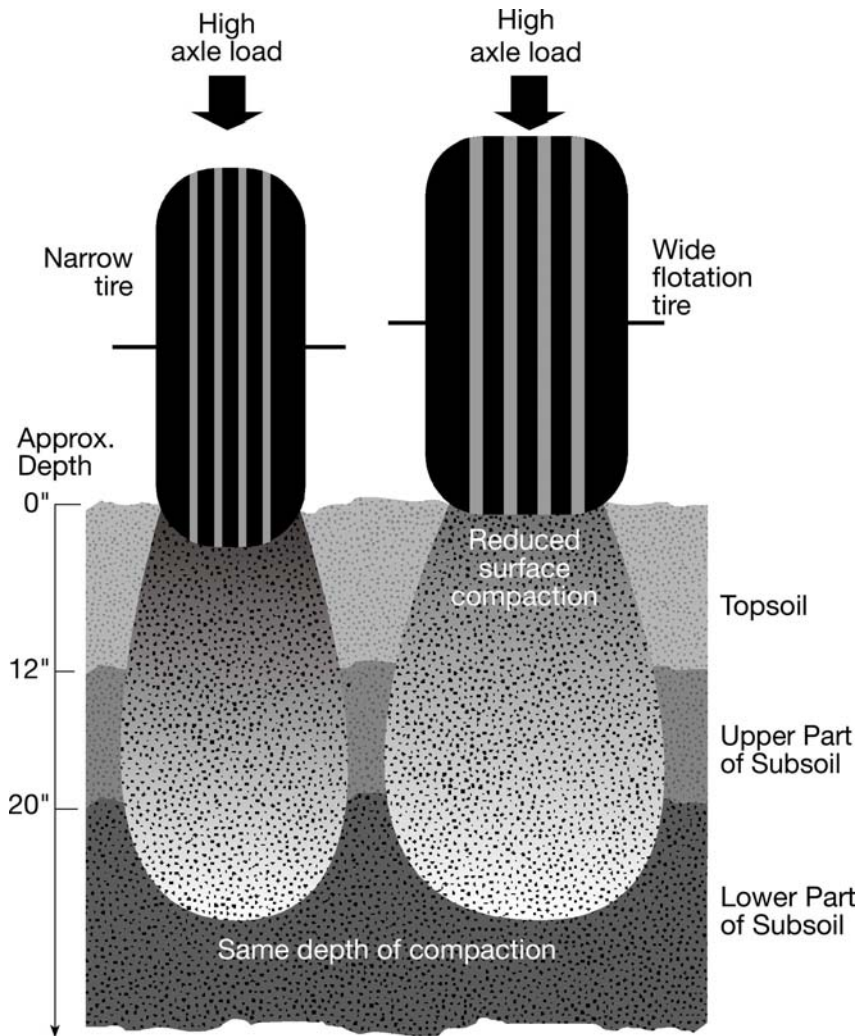

Subsoil compaction

Subsoil compaction (Figure 6.6) is caused by axle load (expressed in tons). The higher the axle (or wheel) load, the deeper the stress will be transmitted into the soil.

Figure 6.6. Axle load determines subsoil compaction. Reduction of axle load reduces subsoil compaction.

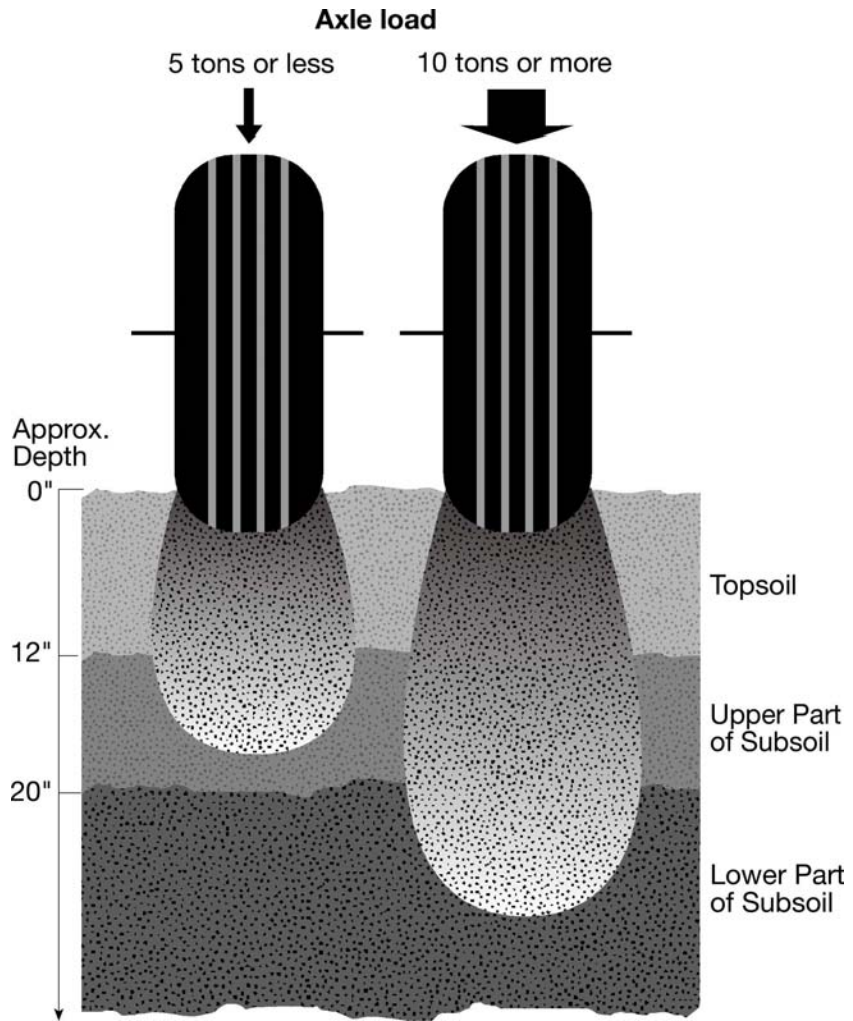

Plow pans

Plow pans are caused just below the tillage tool, if that layer of the soil has a moisture content conducive to compaction at the time of tillage. The moldboard plow (Figure 6.7) is renowned for causing a plow pan, but the disk plow and harrow have also been found to cause plow pans.

Figure 6.7. The moldboard plow is infamous for causing a plow pan just below the depth of plowing.



Natural compaction

Not all compaction is caused by humans. Some glaciated soils have been compacted by glaciers in the past and are still compacted at depth. Other soils have fragipans, which are naturally compacted subsoils high in silt content. Finally, some sandy coastal plain soils have such poor structure in the subsoil that root growth is negatively affected.

Controlling compaction

Avoiding soil compaction

An understanding of the causes of soil compaction makes it possible to develop management strategies that either **avoid** or **remediate** its effects. It is easier to avoid compaction because remediation strategies can be costly and will likely not correct the problem entirely.

The aim of compaction management should be to avoid subsoil compaction altogether and to limit surface compaction as much as possible. Soil compaction is not likely to cause much damage if traffic is limited to dry soil conditions. If soil is moist, however, the following is important:

- To avoid subsoil compaction, reduce axle load at least below 10 tons by:
 - reducing load
 - increasing number of axles

- To avoid surface compaction, reduce contact pressure (should be no higher than 35 psi), by:
 - reducing tire pressures to minimal allowable pressures
 - using flotation tires
 - using tracks or duals to replace singles
 - using radial-ply instead of bias-ply tires
 - installing larger diameter tires to increase length of footprint
 - properly ballasting tractor for each field operation

It is also advisable to reduce the number of passes over the field and to limit the area of the field that is impacted by traffic. This can be done by increasing swath width of spreading and spraying equipment and reducing width of tracks.

- To avoid plow pans:
 - do not drive a tractor wheel in the furrow
 - use no-tillage
 - use a chisel instead of moldboard plow
 - use a field cultivator instead of disk harrow

A producer can make the soil more resistant to compaction by increasing its organic matter content and by building a soil ecosystem that has a permanent macro-pore system. There is now much interest in using cover crops with root systems that serve to reduce or remediate the effects of soil compaction.

Choosing equipment for remediating compaction

If the diagnosis has determined that tillage is justified, it becomes necessary to select the best tillage tool to remediate compaction. Leaving 30% residue cover after planting is recommended to reduce erosion and increase soil quality, so the tillage tool selected should not reduce residue cover below this level.

The moldboard plow is not recommended for remediation of soil compaction because it buries most residue and can actually lead to the formation of a plow pan. Chisel plows are better suited than moldboard plows for alleviating compaction if they can penetrate the compacted soil, but the tension springs on the chisel plows are not often heavy enough to penetrate the compacted

layer. In this situation, subsoilers are often used.

Traditional subsoiler shanks are heavy, wide, and have curved shanks and large points. These subsoilers were designed to cause maximum fracturing and disturbance of the soil. At the same time, however, they bury much residue and leave a rough surface that necessitates secondary tillage. Clearly, residue conservation and reduction of secondary tillage were not considerations at the time these subsoilers were designed.

Modern subsoilers are designed differently. They usually have narrow shanks, have coulters to cut through residue in front of the shank, and have some type of attachment to leave the soil in a condition that is ready to be planted. These subsoilers leave most residues at the soil surface and do not create much surface disturbance. They vary in subsoil disturbance according to their design. Two examples of these modern subsoilers are shown in Figure 6.8.

Using cover crops to ameliorate compaction

Cover crops are increasingly used to correct compaction. These cover crops are planted in the fall and grow when soil moisture contents are high and soil is easy to penetrate. Some cover crops have a taproot that can create channels into the subsoil. Other cover crops have a massive, fine root system that intermeshes with soil particles, stabilizing aggregation and creating many small channels. Roots of summer crops can take advantage of the channels created by the cover crop roots at a time when soil moisture content is typically lower than in the winter. More research is needed to further substantiate the benefits of cover crops for soil compaction alleviation and to enable better recommendations for cover crop selection and management for this purpose.

Figure 6.8. Two types of modern subsoilers that break through subsoil compaction while conserving surface residue cover.



Residue management and conservation tillage

Crop residue management

Crop Residue Management (CRM) is a year-round process that begins with the selection of crops that produce sufficient quantities of residue and may also include the use of cover crops after low residue producing crops. CRM will influence all field operations that affect residue amounts, orientation, and distribution throughout the period requiring protection. Residue cover amounts are usually expressed in percentage but may also be expressed in pounds. CRM is an “umbrella” term encompassing several tillage systems including no-till, ridge-till, mulch-till, and reduced-till.

Conservation tillage

Conservation tillage is a generic term that includes many varied tillage systems that leave more than 30% crop residue cover after planting. Conservation tillage can include no-till, minimum tillage systems, zone tillage, strip tillage, and ridge tillage, as long as these systems leave more than the required residue cover after planting. The residue limit of 30% was established as a result of the relationship between residue cover and inter-rill erosion (Figure 6.9), because an increase from 0 to 30% residue cover results in a 70% reduction of inter-rill soil loss.

Figure 6.9. The 30% residue cover limit that defines conservation tillage is based on the relationship between residue cover and inter-rill erosion.

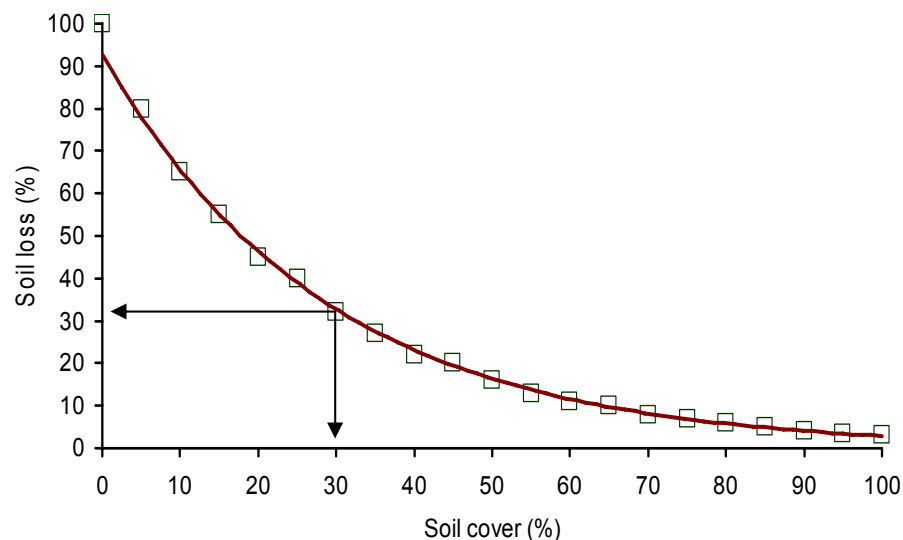

Tillage system definitions

The following definitions were adapted from those given by the Conservation Technology Information Center (2005):

- *No-till/strip-till* (>30% residue):
 - Soil is left undisturbed from harvest to planting except for strips up to 1/3 of the row width. These strips may involve only residue disturbance or may include soil disturbance.
 - Planting or drilling is accomplished using disc openers, coulters, row cleaners, in-row chisels or roto-tillers.
 - Weed control is accomplished primarily with herbicides. Cultivation may be used for emergency weed control.
 - Other common terms used to describe no-till include direct seeding, slot planting, zero-till, row-till, and slot-till.
- *Ridge-till* (>30% residue):
 - The soil is left undisturbed from harvest to planting except for strips up to 1/3 of the row width.
 - Planting is completed on the ridge with sweeps, disk openers, coulters, or row cleaners, and usually involves the removal of the top of the ridge.
 - Residue is left on the surface between ridges.
 - Weed control is accomplished with herbicides (frequently banded) or cultivation.
 - Ridges are rebuilt during row cultivation.
- *Mulch-till* (>30% residue):
 - Full-width tillage involving one or more tillage trips which disturb the entire soil surface. Tillage tools such as chisels, field cultivators, disks, sweeps, or blades are used.
 - Done prior to and/or during planting.
 - Weed control is accomplished with herbicides or cultivation.
- *Reduced-till* (15-30% residue):
 - Full-width tillage involving one or more tillage trips which disturb the entire soil surface.
 - Done prior to planting. There is 15-30% residue cover after planting or 500 to 1,000 pounds per acre of small grain residue equivalent throughout the critical wind erosion period.
 - Weed control is accomplished with herbicides or row cultivation.
- *Conventional-till or intensive-till* (<30% residue):
 - Full width tillage which disturbs the entire soil surface and is performed prior to and/or during planting. There is less than 15% residue cover after planting, or less than 500 pounds per acre of small grain residue equivalent throughout the critical wind erosion period.
 - Generally involves plowing or intensive (numerous) tillage trips.

- Weed control is accomplished with herbicides or row cultivation.
 - *Stale seedbed*:
 - Not an official tillage category.
 - Fields are tilled full-width soon after harvest. The seedbed “settles” until planting is performed in the undisturbed (settled) seedbed or in re-formed beds (minimum disturbance).
 - Weeds and/or cover crops are controlled with herbicides or row cultivation.
-

**Tillage systems
in the Mid-
Atlantic**

The adoption of conservation tillage virtually stagnated in the Mid-Atlantic and Northeast U.S. between 1990 and 2004 (Figure 6.10). This does not mean that no changes in tillage practices have taken place, but, rather, it means that, in many cases, the residue cover requirements for conservation tillage are not met.

Over the past two decades there has been a gradual shift by farmers away from the moldboard plow to the chisel plow as the primary tillage tool. Because of low residue cover left by the preceding crop or because of secondary tillage operations, however, the level of residue cover left after chisel plowing and secondary tillage operations is usually less than 30% residue cover. The only two common field crops that leave enough residue to enable chisel plowing and still maintain 30% residue cover after planting are high-yielding corn or small grains harvested for grain.

Another change in tillage practices has been within the conservation tillage class. There has been a steady increase in no-tillage, but this increase has been at the expense of other conservation tillage practices such as chisel plowing and disking.

Figure 6.10. Tillage systems in the Northeast, including Mid-Atlantic states (Conservation Technology Information Center, 2005).

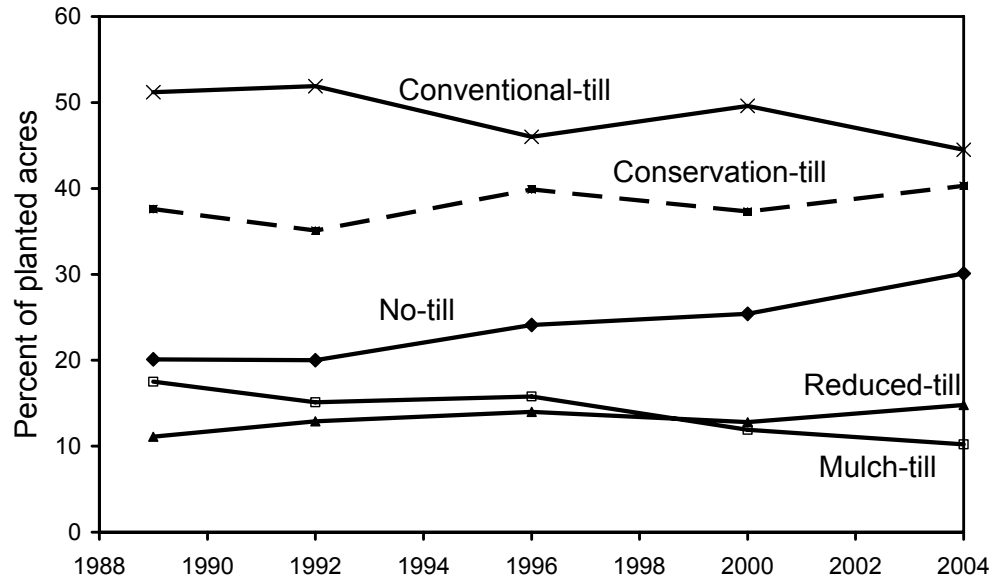

Notes:

1) "Northeast" includes: Connecticut, Delaware, Maine, Maryland, Massachusetts, New Hampshire, New Jersey, New York, Pennsylvania, Rhode Island, Vermont, Virginia, and West Virginia.

2) Conservation-till is the sum of no-till and mulch-till.

No-tillage

In recent years there has been an increasing realization of the negative aspects of soil tillage:

- takes time
- costs money (fuel, equipment, maintenance)
- increases erosion
- reduces organic matter content
- destroys soil tilth
- promotes soil crusting
- increases runoff
- increases evaporation losses
- reduces biological activity (e.g. earthworms)
- brings rocks to surface

These negative attributes of tillage explain the increased adoption of no-tillage. However, a major concern of producers that may have slowed the adoption of no-till is whether they can produce the same yields as with tillage. No-tillage is most challenging on poorly drained soils. In addition, the northern sections of the Mid-Atlantic region have a short growing season for corn, so slower warming of no-till soils may sometimes reduce corn yields there. On most soils in the region, however, no-till yields should be similar to

yields obtained with tillage, and no-till should out-yield tilled crops in areas where drought stress is a problem, due to the water conserved by the mulch cover.

As the adoption of no-till increases, we continue to learn more about it. There is now an increasing realization that:

- No-till without or with little mulch is not a sustainable practice. Almost all environmental benefits of no-tillage are due to the mulch cover at the soil surface.
 - Soil improvement with no-till takes years. Continuous no-till is recommended because rotating tillage and no-till destroys the soil-building benefits of no-till.
 - No-till affects many other aspects of crop production (nutrient, weed and pest dynamics; residue distribution) that need to be integrated into a systems approach. Crop rotations and cover crops are central to this systems approach.
-

Cover crops

Cover crops can provide many benefits, including:

- erosion control
- organic matter increase
- soil structure improvement
- atmospheric nitrogen fixation
- nitrate recapture
- soil water management
- weed control

The reason for using a cover crop will determine which cover crop should be used and how it should be managed. A cover crop should provide quick cover, have an extensive root system, and preferably survive the winter. If the cover crops are killed without tillage and the main crop established with no-till methods, additional erosion protection will be provided by the resulting mulch.

Small grains such as rye, wheat, and oats are excellent cover crops that protect soil from erosion, improve its organic matter content and structure and capture nitrates after summer crop harvest. Erosion protection is especially critical after low residue crops such as corn silage, soybeans, and vegetables. Small grain cover crops are also preferred to increase organic matter content because of their large biomass production and high C:N ratio after boot stage. Their fine and extensive root system helps improve soil structure and take up nitrate, thus preventing this mobile nutrient from leaching to groundwater.

Rye is the most winter hardy of the winter cereal cover crops. It produces a heavy cover in the spring. Rye takes up much moisture once its stem extension begins. This can help dry up wet soils, providing earlier field access. Some rye varieties have *allelopathic* properties, which means they can suppress weeds.

Wheat is also winter hardy in most of the region. It does not grow as fast as rye in the spring and is, therefore, easier to manage.

Spring oats winter-kill in December in most of the Mid-Atlantic region and should be established early to allow enough biomass accumulation. Although oats are easy to manage, they provide fewer benefits than rye and wheat because of their early winter-kill in many areas.

Leguminous cover crops such as hairy vetch, crimson clover, red clover, white clover, and winter pea are used to fix nitrogen (see Chapter 4 for N-supplying capacity of legume cover crops). To achieve successful results with these cover crops, they need to be established in a timely manner and allowed to accumulate enough biomass.

Brassica cover crops such as radish and mustards are receiving increased attention because of their taproots, which can create large pore spaces in the subsoil. These pores can later be occupied by summer crop roots. *Brassica* species also have allelopathic properties that can help with weed control.

References cited

Conservation Technology Information Center. 2005. Web page available on-line at: <http://www.ctic.purdue.edu/CTIC/CRM.html>.

Doran, J.W., D.C. Coleman, D.F. Bezdicek, and B.A. Stewart (eds.) 1994. Defining soil quality for a sustainable environment. SSSA Special Publication number 35. Soil Science Society of America, Madison, WI.

Doran, J.W. and T.B. Parkin. 1994. Defining and assessing soil quality. p. 3-21. *In* Doran, J.W. et al. (eds.) Defining soil quality for a sustainable environment. SSSA Special Publication number 35. Soil Science Society of America, Madison, WI.

Doran, J.W. and T.B. Parkin. 1996. Quantitative indicators of soil quality: A minimum data set. p. 25-37. *In* Doran, J.W. and A.J. Jones (eds.) Methods for assessing soil quality. Soil Science Society of America, Madison, WI.

Hakansson, I., and R.C. Reeder. 1994. Subsoil compaction by vehicles with high axle load - extent, persistence and crop response. *Soil Tillage Research* 29:277-304.

Magdoff, F. and H. van Es. 2000. Building soils for better crops. 2nd edition. Sustainable Agriculture Publications, Burlington, VT.

Renard, K.G., D.K. McCool, K.R. Cooley, G.R. Foster, J.D. Istok and C.K. Mutchler. 1997. Rainfall-runoff erosivity factor (R). p 9-64. *In* Renard, K.G. et al. (eds.) Predicting soil erosion by water: A guide to conservation planning with the Revised Universal Soil Loss Equation (RUSLE). Agriculture Handbook Number 703. USDA-ARS, Washington DC.

Chapter 7. Nutrient Testing, Analysis, and Assessment

Douglas Beegle

Department of Crop and Soil Sciences, Penn State University

Table of Contents

Soil testing	153
Components of a soil testing program	153
Soil sampling	153
Understanding soil variability	153
Nutrient variability under conventional tillage	154
Nutrient variability under no-tillage and reduced tillage	155
Variability in pH under no-tillage	155
Collecting a representative soil sample	157
Sampling depths	157
Sampling patterns: random	158
Sampling patterns: grid sampling	158
Soil fertility maps	159
Sampling on the basis of known or suspected variability	160
Soil laboratory analysis	161
Understanding soil test extractants	161
Using soil test procedures recommended for your region	162
Soil test interpretation	164
The soil test-yield response relationship	164
Soil testing interpretation categories	165
Defining the terms used for interpretation categories	165
Predicting potential environmental impact from nutrients	167
Soil test recommendations	168
Developing fertilizer recommen-dations	168
Fertilizing the soil vs. fertilizing the crop	169
Assessing soil acidity	171
Soil pH and lime requirement	171
Assessing soil N levels	172
Introduction	172
The Pre-sidedress Soil Nitrate test	173
Test-based recommen-dations for N	174
Chlorophyll meter N test	175
Late Season Stalk Nitrate Test	176
Assessing soil P levels for environmental management	177
The critical source area approach	177
The Phosphorus Index	178
Using the P Index in nutrient management planning	180

Plant analysis	180
Purpose of plant analysis	180
Elements analyzed	180
Sampling plant tissue for elemental analysis	181
Sampling in different situations	181
When and what to sample	181
Multiple sampling for diagnosing nutritional problems	182
Interpreting plant analysis data	183
Introduction.....	183
Critical levels and sufficiency ranges	183
Using plant analysis data to determine timing of nutrient addition, and nutrient use efficiency.....	184
Using plant analysis data with soil test results.....	184
References cited.....	186

Soil testing

Components of a soil testing program

A soil testing program can be divided into four main components: sample collection, laboratory analysis, interpretation of results, and the recommendations for nutrient application. This chapter describes these four components. It is important to understand all these components to maximize the effectiveness of soil testing.

Two types of soil tests are run routinely. Soil tests for properties such as pH and CEC are direct measures or estimates of soil properties that affect the fertility of the soil. Other soil tests (for example, those for P, K, Ca, Mg, and micronutrients) use extractants to assess the amount of each nutrient that is related to the plant-availability of that nutrient.

Soil testing is also being used in environmental management to reduce non-point source pollution from agriculture. Use of P soil tests in the Phosphorus Index is an example of this and is discussed in this chapter.

Soil sampling

Understanding soil variability

The largest source of error in soil testing usually results from not obtaining representative samples. Frequently, these sampling errors are due to the inherent variability of soils. This variability can be either natural or man-made.

- *Natural variability* in nutrient levels is due to ongoing soil forming processes and is characterized by soil properties such as soil texture, mineralogy, depth, drainage, slope, aspect, and landscape location. For example, there are often major differences in nutrient concentrations with depth due to horizonation of the soil profile. Sandy-textured soils have a lower cation exchange capacity (CEC) and will hold fewer cations such as calcium (Ca), magnesium (Mg), and potassium (K). Low nitrogen (N) concentrations, due to denitrification, may be found in low lying, wet soils.
- *Man-made variability* in nutrient levels is usually due to farming practices. The most obvious source of man-made variation in soil nutrients is the uneven application of nutrients as fertilizers or manures. Uneven application may be intentional, such as when fertilizer is banded or manure is injected. It may also be caused unintentionally by improper adjustment or operation of application equipment.

Tillage is a very important factor in man-made nutrient variation in the soil. The following sections describe how different tillage systems affect soil nutrient and pH content.

Nutrient variability under conventional tillage

The repeated mixing of the surface layer of soil by conventional tillage reduces the effects of man-made variation due to nutrient application.

Conventional tillage can also increase the variability of soil test levels over time if tillage is not performed consistently. For example, the depth of plowing can alter soil nutrient concentrations. Occasionally, deep plowing may mix low fertility subsoil material with the plow layer and thus, lower the soil test levels for nutrients in this soil layer.

Cultural practices performed after tillage (e.g., banding a starter fertilizer), however, can result in variation for the rest of the growing season. The spike in Figure 7.1 is an example of the effect of the starter fertilizer band from the previous year. This variability will persist until the fall or early spring and must be taken into account when soil testing is performed for the next year's fertilizer recommendations. Consequently, for example, most labs recommend sampling in the middle of the row to avoid the effects of banded fertilizer from the previous year.

Figure 7.1. Variation in P across the row and with depth in a long term conventional till corn field.

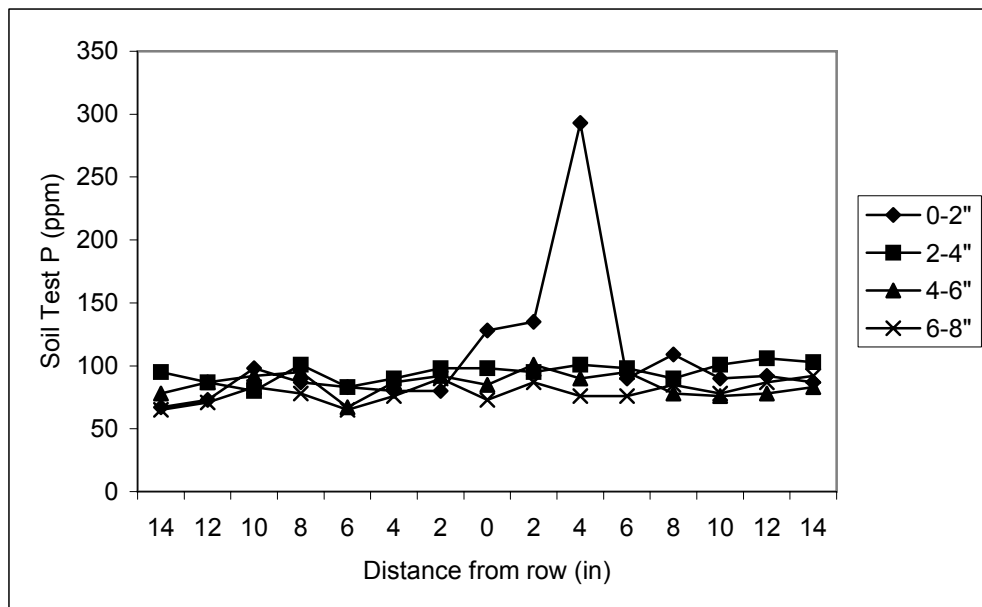

Nutrient variability under no-tillage and reduced tillage

In no-tillage and reduced tillage systems, there is increased emphasis on residue management, which results in even more soil nutrient variation. There is no mechanical mixing of the soil in no-tillage systems, so natural or man-made variation in soil nutrient levels tends to become amplified over time. Application of immobile nutrients such as P in fertilizer or manure will result in higher soil test nutrient levels near the surface and declining soil test levels with distance down through the plow layer (Figure 7.2). Nutrients and organic matter released from crop residues also accumulate at the soil surface.

Figure 7.2. Variation in P across the row and with depth in a corn field in long-term conservation tillage.

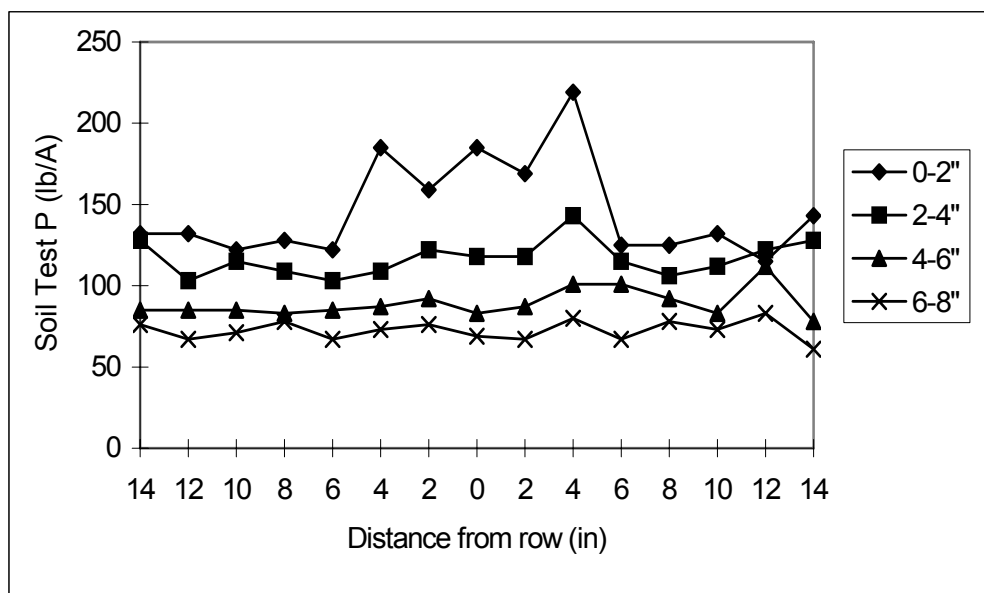

Variability in pH under no-tillage

Variation in soil pH with depth often results from no-tillage systems. Nitrification of surface-applied fertilizer and manure N causes lower soil pH at the surface of no-till fields (Figure 7.3).

The effects of surface-applied limestone will be greatest at the surface of the soil because limestone is immobile in the soil. Thus, limestone application will usually result in a higher pH near to the soil surface. Figure 7.4 shows that when the lime is applied to the soil surface of a continuous no-till field, there is little pH effect below the surface 2 inches even after 7 years.

Figure 7.3. Variation in pH across the row and with depth in a long term no-till corn field.

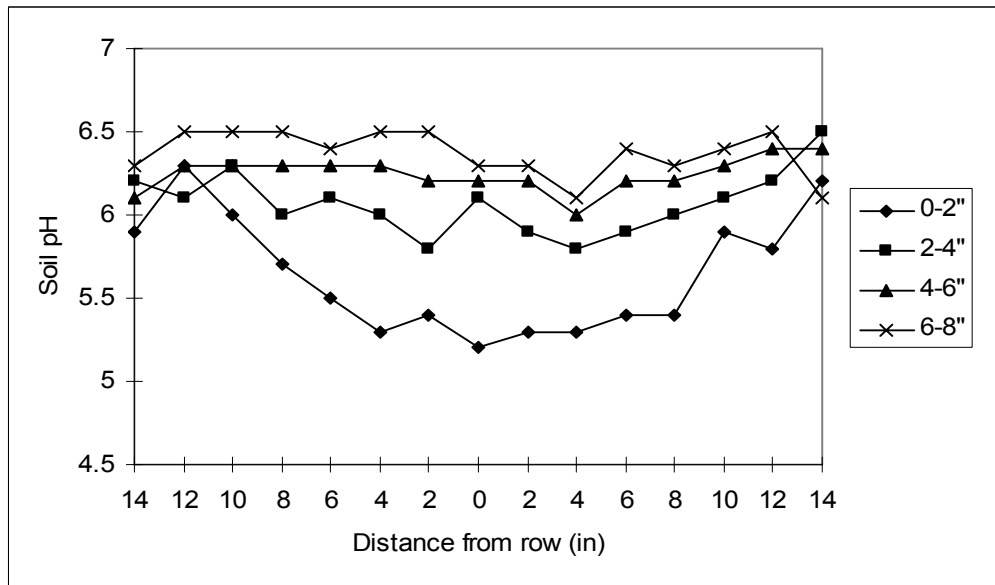
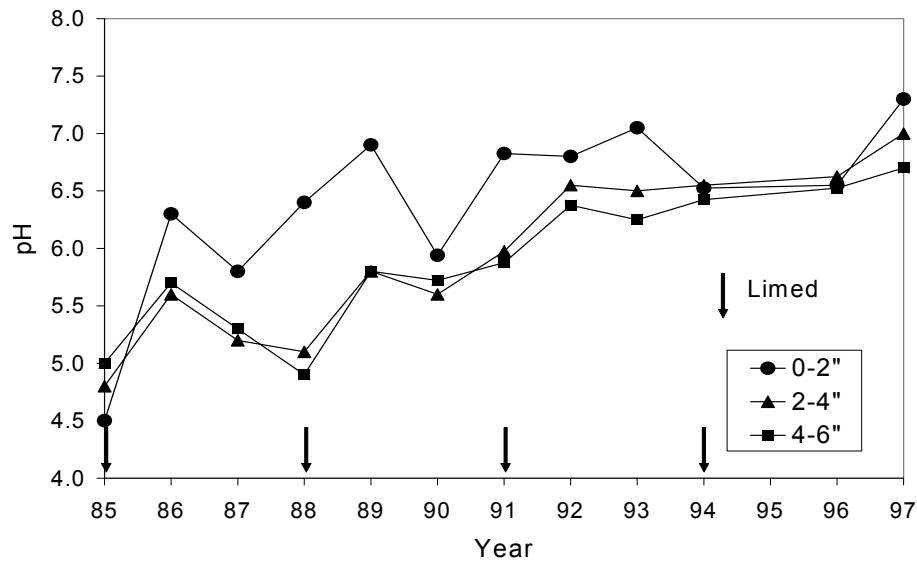

Figure 7.4. Soil pH vs. time for a no-till soil limed at 6000 lb/A every third year.



Collecting a representative soil sample

With all of this variation in field soils, it is easy to see why collecting a representative soil sample is a major potential source of error in soil testing. In a 10-acre field there are approximately 20 million pounds of soil in the plow layer. Out of this, a sample of 1/4 pound is collected that will ideally represent all of the soil in the field. A handful of soil grabbed from the surface along the road at the edge of the field is not likely to be representative of the rest of the field. Thus, a rigorous procedure for obtaining a representative soil sample must be followed.

The two main questions that must be considered when developing the sampling plan for a field are:

- How deep should the samples be taken?
 - What pattern should be followed when selecting sampling locations?
-

Sampling depths

Depth is an important factor that must be considered in developing a sampling plan for a field. Traditionally, it has been recommended to sample the plow layer (6-8 inches) for P, K, Ca, Mg, micronutrients, pH, and lime testing.

Under **conventional tillage**, nutrients and pH in the plow layer of soil are most affected by nutrient additions and have the greatest impact on crop nutrition. For these reasons, this is still the sampling depth recommended by most labs for conventional tillage systems. In addition, shallower sampling usually will not affect fertilization recommendations because the plow layer is uniform throughout under conventional tillage.

In **reduced and no-tillage** systems, the correct sampling depth is less clearly defined, yet the depth sampled has a much greater impact on the soil test result than in conventional tillage systems because nutrients concentrate near the surface. Root systems and nutrient uptake zones are also concentrated near the surface in conservation tillage systems, so shallower sampling than 6-8 inches may be more appropriate. Some soil testing labs now recommend that minimum and no-till fields be sampled to “plow depth,” and that an additional shallower sample of 1 to 2 inches be taken, primarily for measurement of soil pH. It is usually recommended that soil be sampled to a depth of 2 to 4 inches for routine soil tests under permanent sod crops.

The recommended sampling depth for **nitrogen** is deeper than for other soil tests because of the greater mobility of nitrogen. The most common soil test for nitrogen in the humid region of the United States is the pre-sidedress soil nitrate test (PSNT) for corn. The recommended sampling depth for this test is 12 inches.

The above are general guidelines for sampling depth, but because soil test interpretations and recommendations are based on a specific sampling

procedure, it is critical that the exact instructions from the soil testing lab be followed.

Sampling patterns: random

There are two general patterns for sampling a field: *random sampling* and *grid sampling* (or systematic sampling).

The best approach for a uniform field is to collect a *random* composite sample by randomly selecting locations in the field from which to take soil cores, which are then thoroughly mixed and subsampled for lab analysis. The result is an average soil test level for the field. Usually, 15 to 20 cores are taken at random locations to make up the composite sample. In practice, the locations for taking cores are not usually chosen completely at random, but are selected by walking a zigzag pattern that covers the whole field and approximates a random sample and collecting a core at regular intervals (Figure 7.5).

Figure 7.5. Example of a random sampling pattern in a field.

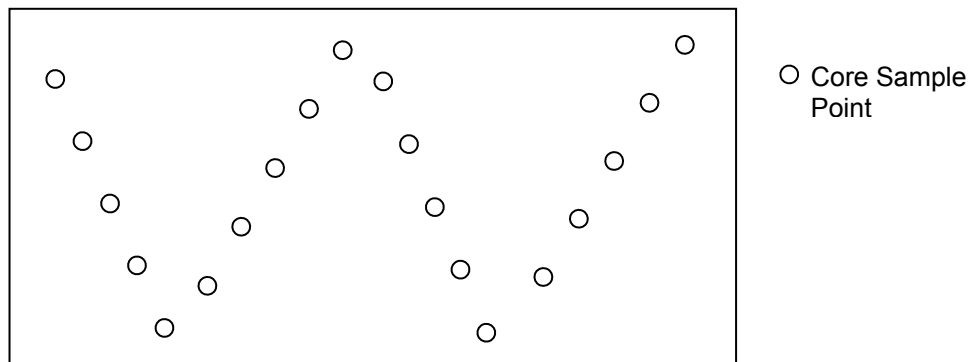

Sampling patterns: grid sampling

A soil test value from a composite sample may not be very useful for a non-uniform field. In this situation, the field is comprised of several distinctly different soil test levels because of natural or man-made variation caused by different soil types, topographic locations, previous management, old field layouts, and so forth. Thus, the soil test value resulting from a randomly collected composite sample may not actually exist anywhere in the field.

Ideally, the variability in a non-uniform field should be determined and mapped to permit the various areas of the field to be managed differently. The usefulness of characterizing the variability in a field will depend on the ability to change management based on this variability. A *grid sampling* (or *systematic sampling*) approach is often used to map the variability of a field.

To accomplish this, a grid is superimposed on the field. A common grid size is 2 acres or approximately 300 feet on a side. At each intersection of grid

lines, 5 to 10 soil cores are taken within a 10 foot circle and composited to make up the sample for that point (Figure 7.6). This systematic sampling approach is best suited for large, regularly-shaped fields.

Figure 7.6. Example of a systematic or grid sampling pattern in a field.

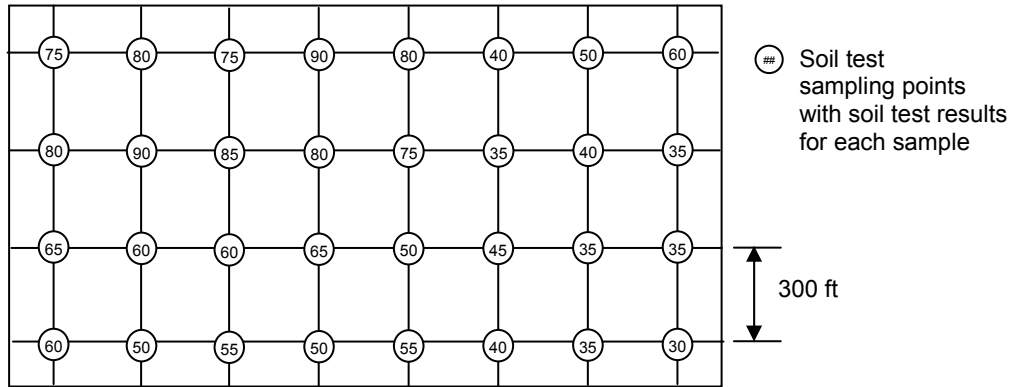

Soil fertility maps

Analysis of the composite samples from each of these grid points is used to make a *soil fertility map* showing the variation across the field. A simple example of such a map is shown in Figure 7.7. Notice the generally high levels along the northwest side of the field. The southeast end of the field has very low soil test levels with some medium and low areas in between. Ideally, nutrient application rates will be adjusted accordingly when fertilizer or manure is applied to this field.

Figure 7.7. Example of a soil fertility map. This is a map of soil test levels based on the analyses of the samples taken from the grid layout.

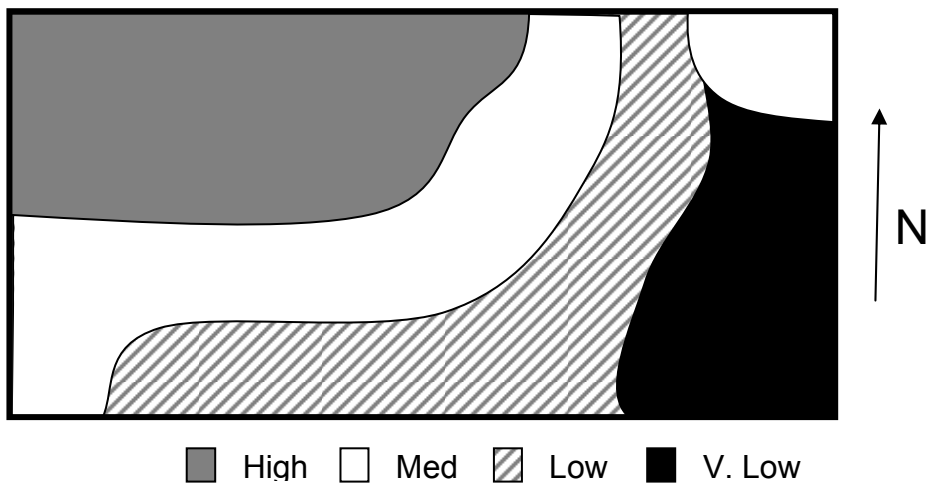

Sampling on the basis of known or suspected variability

Small and irregularly shaped fields make grid sampling and variable management very difficult. One common compromise is to systematically sample on the basis of known or suspected variability in the field. Examples of known or suspected variability might include: historical manure or fertilizer spreading patterns, soil drainage, soil type, slope, etc. This type of sampling is illustrated in Figure 7.8. In this field, three areas that could be sampled and managed separately include an old barnyard area that has historically had heavy manure applications and is expected to contain high organic matter and nutrient concentrations; a small area of wet soil that is not productive and has not received much manure; and a well-drained unmanured area.

Figure 7.8. Example of systematically dividing a field for soil sampling on the basis of known or suspected variability. An individual composite sample would be taken and analyzed from each different area in the field.

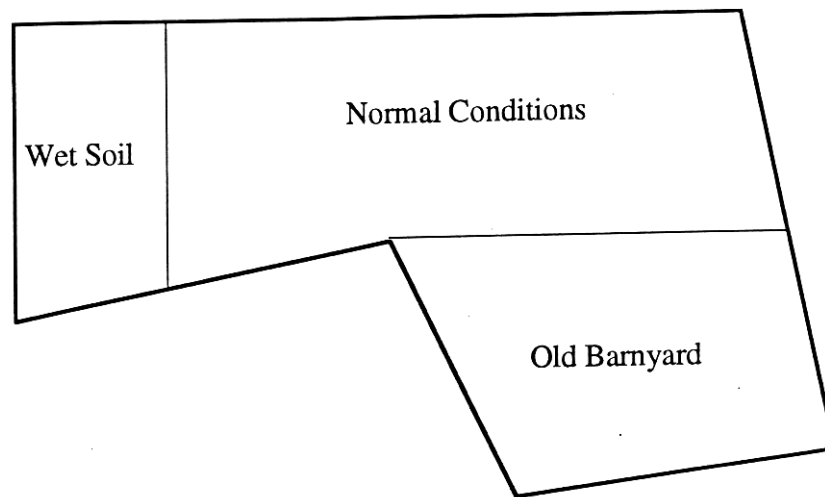

One should not attempt to take a random composite sample that represents the whole field depicted in Figure 7.8. The result of the soil tests on that composite sample will be useless in most cases. If the field can not be divided, sampled, and managed separately, it is probably best to sample the largest and/or most productive section of the field and ignore the odd areas.

Soil laboratory analysis

Understanding soil test extractants

Laboratory analysis of a properly sampled soil provides the basis for assessing soil nutrient status. With few exceptions, such as the measurement of NO_3^- -N, most soil test extractants do not directly measure the total amount of available nutrients in the soil because there is usually not a clear cut distinction between available and unavailable nutrients.

Part A of Figure 7.9 illustrates the commonly held misconception about available nutrients in the soil. The availability of nutrients ranges from completely insoluble (unavailable) to completely soluble (readily available). Availability is a relative term covering this entire range. Soil tests generally extract a fraction of the nutrient from the soil that is correlated to the plant-available portion of that nutrient.

Different extraction methods can extract different amounts of nutrients and provide different soil test results. Research is conducted to determine which soil test extractant works best for predicting the ability of a soil to supply available nutrients for crop uptake under conditions where the test will be used.

An example of how three extractants might extract different fractions from the same soil, resulting in three differing soil test levels, is illustrated in part B of Figure 7.9. All three of these extracted fractions may be correlated with plant availability, or one of these tests may perform better under certain conditions. It is important to use a test that has been verified to work under conditions similar to the ones in your area.

Figure 7.9. Illustration of how different soil test extractants might extract different fractions of the nutrient in the soil. A is the common **incorrect** view of nutrient availability and soil test extraction. B is nutrient availability as a continuum, showing how different soil tests ($ST_{A,B,C}$) extract different fractions of this continuum. (In this example, the numbers would be representative of ppm P by ST_A = Mehlich 3, ST_B =Bray P1, ST_C = Modified Morgan.)

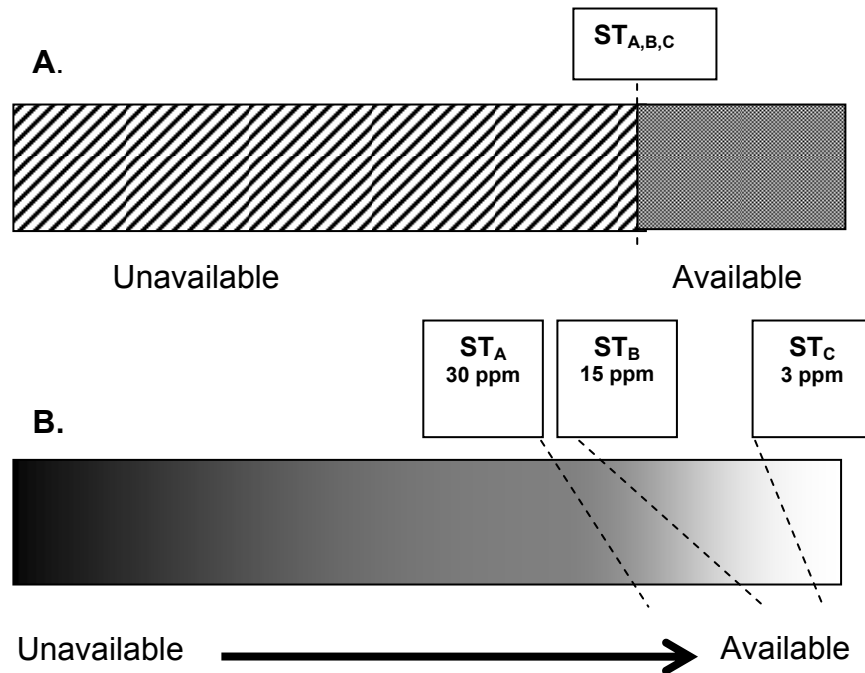

Using soil test procedures recommended for your region

Generally, the soil test user need not be concerned with the details of the soil test methods. The most important consideration for the user is that the testing lab is using **standard procedures that are recommended for the region** where the samples were collected. If not, the results and/or interpretations may be misleading. Be careful if you consider sending samples to a lab in another part of the country. The lab may have an excellent reputation, but the procedures that they use may be totally inappropriate for Mid-Atlantic soil conditions.

It is also important to know which analytical methods are used when comparing results from different labs. You should only compare results from laboratories that use the same methods. If test results from two different labs are being compared and both are valid for the area where the sample was taken, the interpretation of the results should be the same even though the numerical analytical results from the two tests might differ.

In the Mid-Atlantic region, the most common analytical method used is the *Mehlich 3* soil test. Other methods that have been used (and that are still used

occasionally) in the region are the Mehlich 1, Bray P1, and 1N Ammonium Acetate. Each of these methods will extract a different amount of the nutrient but, if properly calibrated, they can all provide valid results for our region. Some states have developed conversions between the different methods. -Use conversion factors with caution. It is always better to use the recommended test rather than using an alternative test and converting the results.

The **units employed to express soil test results** sometimes cause confusion. The most common system is based on an actual or assumed weight for the soil. Results in this system are usually presented as parts per million (ppm) or pounds per acre (lb/A). As a further complication, some labs present results as pure elements (i.e., P, K), while others use the fertilizer oxide form (i.e., P₂O₅, K₂O). Results for cations like Ca²⁺, Mg²⁺, and K⁺ are sometimes presented as milliequivalents per 100g (meq/100g). All these units can be converted mathematically to each other. Some common conversion factors are given in Table 7.1.

Table 7.1. Common conversions for soil test units

ppm x 2* = lb/A	lb/A ÷ 2* = ppm
P x 2.3 = P ₂ O ₅	P ₂ O ₅ ÷ 2.3 = P
K x 1.2 = K ₂ O	K ₂ O ÷ 1.2 = K
NO ₃ ⁻ -N x 4.4 = NO ₃ ⁻	NO ₃ ⁻ ÷ 4.4 = NO ₃ -N
meq K/100g x 780 = lb K/A	meq K/100g x 390 = ppm K
meq Mg/100g x 240 = lb Mg/A	meq Mg/100g x 120 = ppm Mg
meq Ca/100g x 400 = lb Ca/A	meq Ca/100g x 200 = ppm Ca

* This factor only applies to furrow slice depth, approximately 7 inches, which is assumed to weigh 2,000,000 lb/A.

Soil test interpretation

The soil test-yield response relationship

The analytical results from a soil test are relatively meaningless by themselves. Soil nutrient levels must be interpreted in terms of the soil's ability to supply the nutrients to crops. To make this interpretation, the soil test level must be calibrated against crop response to the nutrient. This is accomplished by conducting fertilizer response experiments at different soil test levels covering the range of interest for use of the soil test. These experiments must be conducted for all crops and under all the conditions where the test might be used.

An example of the relationship between yield and soil test levels is illustrated in Figure 7.10. In Figure 7.10, the value presented as % yield is the yield in the unfertilized soil divided by the yield in a soil where the nutrient is non-limiting. For example, 70% yield means that the crop yield with the unfertilized soil is 70% of the yield at optimum concentration of the nutrient. This *soil test-yield response relationship* shows that at low soil test levels yields are low relative to the optimum. As soil test levels increase, yield increases until that nutrient is no longer limiting and then the response curve levels off. This point where the relationship levels off is called the *critical level* and indicates the soil test level above which you would not expect a yield increase from adding more of the nutrient.

Soil test critical levels will vary among soils, crops, climatic regions, and extractants. For example, the critical level for soil test phosphorus for the Mehlich 3 soil test is around 30 ppm for Mid-Atlantic soils. If the test is below 30 ppm we would expect a profitable increase if we add P. However, if the soil test is above 30 ppm, no yield response is expected. For soils in the Midwest, this critical level is closer to 20 ppm. Ideally, we would like to maintain the soil test level at the critical level for optimum economic production.

Figure 7.10. Example relationship between yield and soil test level. Each point in the graph would be the relative yield for an individual field experiment.

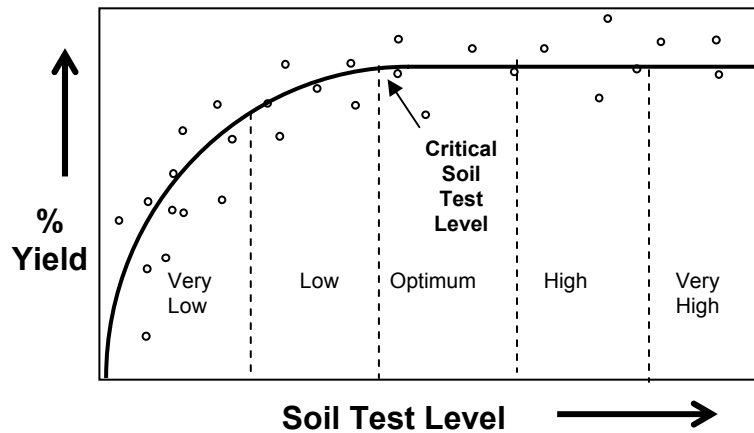

Soil testing interpretation categories

It is important to use a laboratory where the soil test results have been calibrated for your region so that an accurate interpretation of values can be determined. Most soil test laboratories use the response curve from the calibrations to develop *interpretation categories*. The dotted lines and names in Figure 7.10 illustrate how the data might be used to develop soil test interpretation categories.

Defining the terms used for interpretation categories

The qualitative terms used for the interpretation categories are related to quantities of nutrients extracted but may have different absolute meanings depending on the laboratory using them. It is important to understand exactly what these terms mean for any laboratory that you use. For example, Pennsylvania once termed the category that is designated as “Optimum” in Figure 7.10 as “Medium” while Maryland termed that same category as “High”. Today that category is called “Optimum” in both states, which has eliminated the previous confusion between state testing lab results.

Soil test labs may report these interpretations in different ways. Some labs use words such as “Low,” “Optimum,” or “High” while some use abbreviations such as “L,” “O,” or “H.” Often the results are presented in graphical form. An example of an interpretation in the form of a chart from the Penn State Soil Testing Program report is shown in Figure 7.11.

Figure 7.11. Example of a bar chart for displaying the soil test interpretation on a soil test report (from Penn State Soil Testing Program).

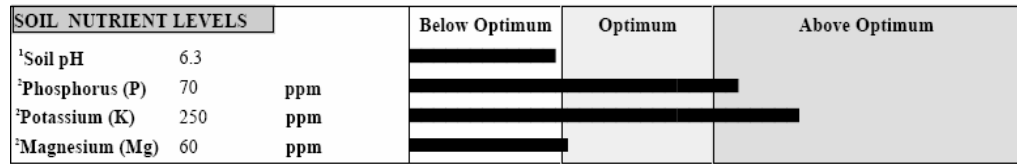

Finally, some labs report their results in the form of an index number. A common index system would assign an index of 100 to the optimum level. With this system, index numbers below 100 would indicate the fraction of nutrient sufficiency, and numbers above 100 would indicate an excess of nutrient over the optimum for the crop.

Regardless of the system used to indicate the interpretation on a soil test report, the lab should provide you with clear definitions of the terms used so that you know exactly what the results mean. For example, the Penn State Soil Testing Program provides the definitions in Table 7.2 on all soil test reports.

Table 7.2. Example of definitions for soil test interpretation categories from the Penn State Soil Testing Program.

Category	Definition and Interpretation
Below Optimum	<ul style="list-style-type: none"> • Indicates that the nutrient is probably deficient and that the deficiency will likely limit crop growth. • High probability of a profitable return from correcting a low level. • Recommendations for a soil testing “below optimum” are designed to gradually build up the nutrient level to optimum and to maintain it at that level.
Optimum	<ul style="list-style-type: none"> • Indicates that the nutrient is probably adequate and will likely not limit crop growth in a typical growing season. • There is a low probability of a profitable return from increasing the soil test level above optimum. • Recommendations for a soil testing “optimum” are designed to offset crop removal in order to maintain the nutrient in the optimum range. • If you are soil testing on an annual basis, no maintenance fertilizer is needed when the soil tests in the optimum range.

Category	Definition and Interpretation
Above Optimum	<ul style="list-style-type: none"> • Indicates that the nutrient is more than adequate and will not limit crop growth. • Very low probability of a profitable return from applying additional nutrients to a soil testing “above optimum.” • No fertilizer is recommended on these soils. Too much of a plant nutrient may cause a nutrient imbalance in the soil and, as a result, in the plant, which may adversely affect plant growth and environmental quality.

Predicting potential environmental impact from nutrients

Soil test results are most commonly interpreted on the basis of the probability of an economic response to adding additional nutrients. Because of the concern about the potential impact of nutrients on the environment, soil tests are increasingly being considered in terms of predicting potential environmental impact from nutrients. However, it is not possible to directly use conventional soil test interpretations for crop response to make an environmental interpretation. If a soil test is above or below optimum for crop response to a particular nutrient, this tells us nothing about whether that level of the nutrient represents an environmental threat. Calibrations that relate soil test level to nutrient loss are required in order to determine this information.

An example of such a relationship between soil test and phosphorus loss is shown in Figure 7.12. One challenge is that there is often not a clear critical level in this type of calibration data. A value judgment is usually needed, and the soil test level should be interpreted in the context of the characteristics of the soil and the site.

One instance of this approach is the *Phosphorus Index*. The Phosphorus Index provides a site vulnerability index for potential P loss based both on the soil test level and on other site characteristics such as soil erosion, irrigation erosion, runoff class, P fertilizer application rate, method of P fertilizer application, organic P (manure, sludge, compost, etc.) application rate, and organic P application method.

Figure 7.12. Example of soil test calibration for P based on environmental impact (adapted from Sharpley et al, 2001).

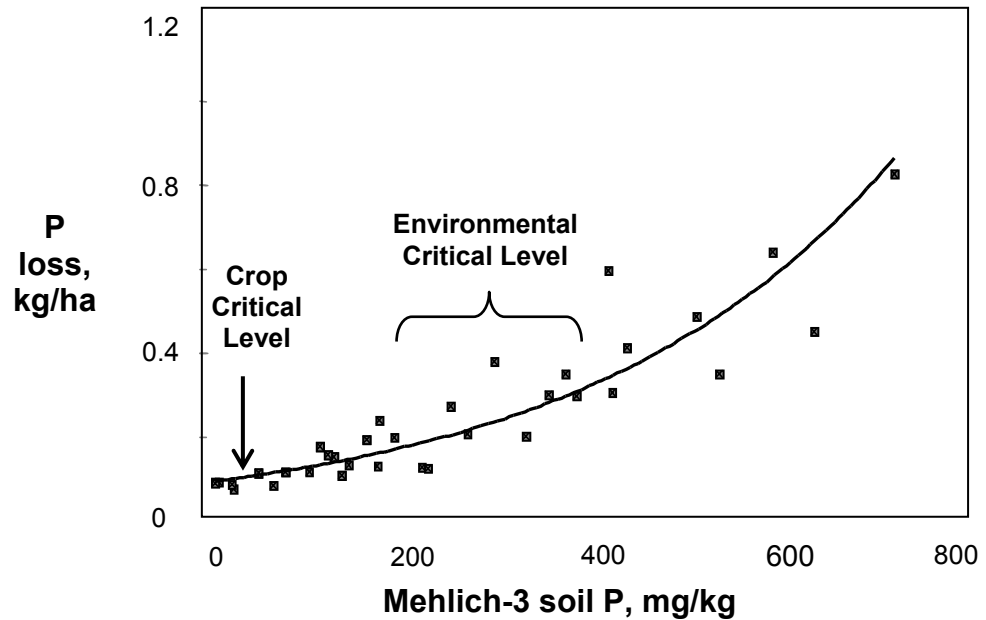

Soil test recommendations

Developing fertilizer recommendations

The final step in the soil testing process is making a recommendation. Soil test calibration studies similar to the one shown in Figure 7.10 can provide the data on whether or not additional nutrients are needed. However, additional information is required in order to determine the appropriate amount to apply.

To determine how much of a nutrient is needed at a given soil test level, experiments with multiple rates of the nutrient are conducted on soils with a range of test levels. For example, in Figure 7.13, rate experiments were conducted on soils with a soil test level of 5 and 15 ppm where 0, 40, 80, and 120 lb/A of the nutrient were applied at each site. At the end of the growing season, yield was plotted versus the fertilizer added for each experiment. From these results we can see that at a 5 ppm soil test, approximately 50 pounds of fertilizer were required for maximum yield. Conversely, at a soil test of 15 ppm, only 20 pounds of fertilizer were required. This type of experiment is then repeated on many sites with different soil test levels below the critical level to develop the relationship between soil test level and nutrient requirement (Figure 7.14).

Figure 7.13. Illustration of how fertilizer recommendations are developed.

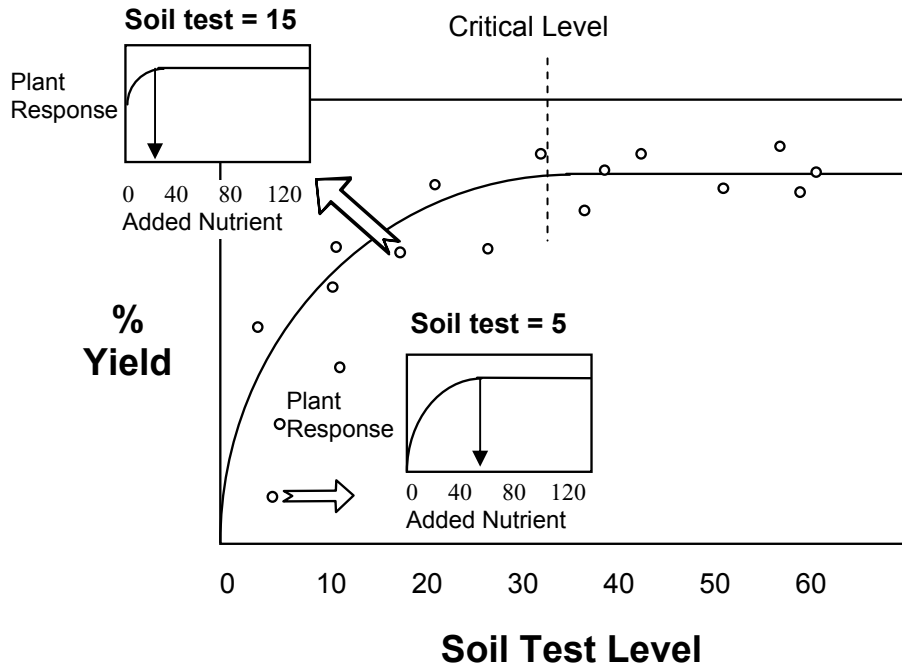
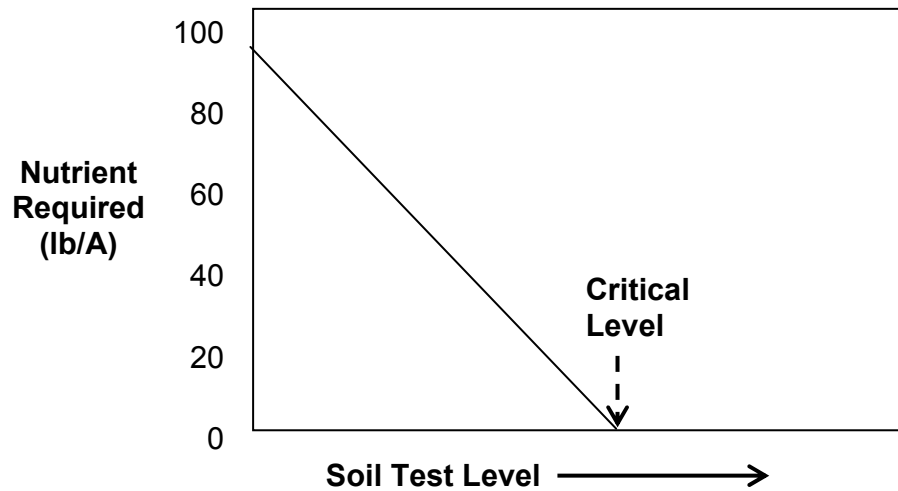

Figure 7.14. Illustration of the relationship between soil test level and nutrient recommendations.



Fertilizing the soil vs. fertilizing the crop

A factor that sometimes results in different recommendations is the philosophy of fertilization recommendations. Fertilizer recommendations are usually based on one of two general approaches: **fertilizing the soil** or **fertilizing the crop**.

Fertilizer recommendations based on **fertilizing the soil** are intended to:

- (1) Build the soil test values to a level determined by field calibrations to be sufficient for optimum crop production (“*buildup*”).
- (2) Maintain that optimum value over time by replacing nutrients removed by the crop.

The “fertilize the soil” approach is most appropriate for longer-term management where a return from the investment in building soil test nutrient values into the optimum range will be achieved. Soil testing every 3 years is recommended with this approach.

Recommendations based on this approach differ in advocating how quickly nutrient levels in the soil should be built up. Some soil testing programs recommend that the soil be built up within the first year of application. This approach can lead to some very large, economically questionable recommendations. Most labs follow a slower approach to buildup, either by dividing the estimated buildup requirement over a certain number of years, or by simply including a small, fixed, “buildup” component to the recommendations for soils with low levels of a particular nutrient.

The maintenance component of the “fertilize the soil” approach is based on the crop nutrient removal, which is estimated from the expected yield of the crop. Long-term average yields and standard crop removal levels for those yields will usually keep soil test levels within the optimum range. If the yield and crop removal estimates are in error, regular soil testing will allow for periodic corrections before soil nutrient levels become too high or too low.

Fertilizer recommendations using the **fertilize the crop** (or *sufficiency level*) approach are based on applying just enough nutrients to achieve optimum response of the crop at a given soil test level. It can be easily argued that this approach has a sounder agronomic and economic basis than the “fertilize the soil” approach. The “fertilize the crop” approach is especially appropriate when short-term economics and short-term land tenure are critical management factors. Numerous public soil testing labs use this method, but it has not been as widely adopted as the “fertilize the soil” approach. Rigorous application of this method requires annual soil testing to determine the nutrient requirement for the current crop, and very few farmers will soil test annually.

Soil test recommendations are increasingly becoming a hybrid of these two strategies. The soil test goal for buildup in the “fertilize the soil” approach is often very close to the critical level for sufficiency in the “fertilize the crop” approach. It is often difficult to clearly distinguish whether the critical level is a sufficiency level for crop fertilization or an optimum level for soil fertilization because of the inherent variability in soil test calibration data and

the high level of uncertainty in determining either the actual sufficiency level for a crop or the optimum value for a soil. This then becomes a question of philosophical perspective and, in some cases, simply semantics. Many labs that use the “fertilize the crop” approach to make recommendations also recognize the periodic nature of soil testing by farmers and include a maintenance component in their recommendations to account for the impact of crop removal on the soil test level between soil testings. In the long run, with periodic soil testing, either approach should result in similar annual recommendations.

Assessing soil acidity

Soil pH and lime requirement

Two soil tests are normally run to provide information to manage soil acidity:

- soil pH
- lime requirement (or buffer pH)

Results from these tests may be the most important parts of a soil assessment, since soil acidity affects many critical processes in the soil-plant system, such as root growth, nutrient solubility, microbial activity, pesticide activity, and others. It is also important that the soil pH be in the optimum range to assure maximum response from other inputs and management.

The soil pH provides a measure of the current acidity level in the soil. The optimum pH for most crops and soils in the Mid-Atlantic region is 6 to 7. The exact optimum varies with the crop and soil conditions. If a soil’s pH is below optimum, it is not possible to determine how much limestone is required from the pH measurement alone. A lime requirement test is run to determine how much limestone will be needed to raise the pH into the optimum range.

Limestone recommendations are made as amount of neutralizing agent to apply, and are usually given as pounds of *calcium carbonate equivalent* (CCE) per acre. The major quality factors that determine the effectiveness of a limestone are CCE, fineness, and Mg content. Limestone recommendations either assume that a certain quality of limestone will be used or provide instructions for adjusting the recommended amount of limestone to account for the quality of the limestone to be used.

Assessing soil N levels

Introduction

Soil testing has been used effectively for years to determine the availability of P and K in agricultural soils and to determine fertilizer recommendations for these nutrients. Due to the complex behavior of nitrogen in the soil, however, development of a reliable soil test for availability of N in humid regions of the country has been more difficult.

In humid regions, a soil test taken before the growing season would not accurately reflect the availability of N later when it is most important to the crop. This is shown in Figure 7.15, which illustrates the considerable increase in soil NO_3^- -N levels from early in the season to the time when the major demand for N by a corn crop occurs. In this example, if the early season soil NO_3^- -N levels were used to predict availability, all of the fields would have the same soil test level and thus, the same recommendation. However, later in the season when the crop takes up most of the nitrogen, nitrogen availability is very different among the fields. Thus, an at-planting NO_3^- -N test would have been misleading and, because of this, attempts to develop a reliable soil test for N as part of a traditional pre-season soil testing program have not been successful. Since corn has the greatest need for N several weeks after emergence, a successful soil test for N should reflect N availability at that time.

Figure 7.15. Relative levels of nitrate-N vs. corn N uptake soil in corn fields with different management systems (R.H. Fox, Penn State University, unpublished data).

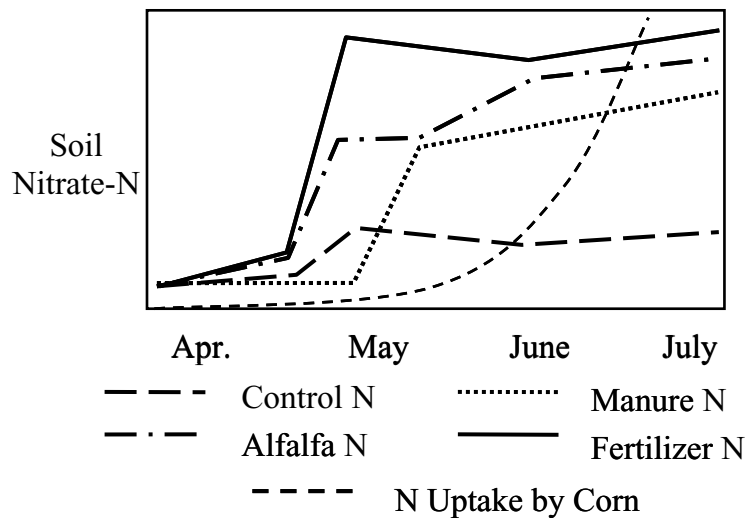

The Pre-sidedress Soil Nitrate test

An approach to N soil testing called the *Pre-sidedress Soil Nitrate Test* (PSNT), which involves soil sampling during the growing season, has been successfully implemented in the Mid-Atlantic region. The PSNT involves taking 12 inch deep soil samples just before sidedressing (after the spring wet period but before the period of major N demand by corn) and determining the amount of NO_3^- -N in this soil sample. At this point in the season, the NO_3^- -N level in the soil is the result of the integration of many factors that influence the soil N transformation from organic forms to NH_4^+ to NO_3^- and has been found to be related to the soil's nitrogen supplying capability over the growing season. The results of the test provide an index of N availability for corn production and are used to make sidedress N recommendations.

Calibration research with the PSNT has resulted in a remarkable consistency in critical levels used to interpret this test. Most critical levels from Vermont to Iowa have fallen between 20 and 25 ppm NO_3^- -N. Data from field research experiments conducted in Pennsylvania, Maryland, and Delaware with the PSNT (Figure 7.16) indicated that the NO_3^- -N level from this test was very good for identifying soils where there would be no yield increase from fertilizing with N (a relative yield near 1 in Figure 7.16).

The vertical line in Figure 7.16 at 21 ppm soil NO_3^- -N is the **critical level** for the PSNT that separates the sites where additional N is needed for maximum yield from those where there is no yield increase when N is added. Almost all the sites with soil NO_3^- -N levels above this critical level did not respond to added N.

Figure 7.16. Pre-sidedress Soil Nitrate Test calibration data from Pennsylvania, Maryland, and Delaware combined (Fox et al., 1992).

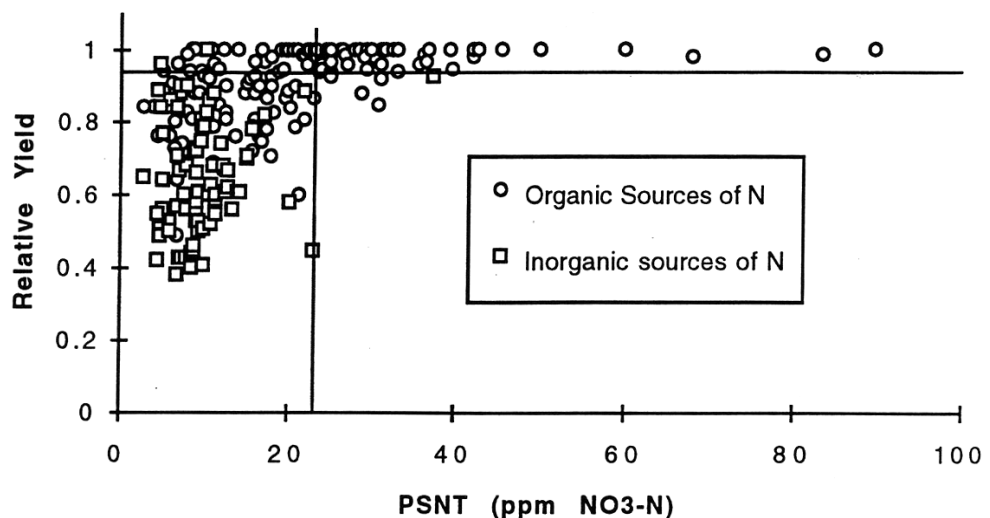

In most states, the PSNT is primarily recommended for use on fields where there are significant organic N contributions such as a history of manure, biosolids applications, or forage legumes in rotation (these are represented by open circles in Figure 7.16). In the past, these fields have been the most difficult sites for which to determine a sound N recommendation. The PSNT is of limited value on most fields without organic N contributions (represented by squares in figure 7.16), because these sites generally have low N levels where the standard recommendations are usually adequate.

The **best use of the PSNT** is to confirm the adequacy of N to meet the needs of a corn crop on sites where it is expected that applied and residual manure nitrogen should be adequate. If the estimate of N available from the manure is found to be inadequate, there is still time to make a sidedress application of N fertilizer. Thus, this test can reduce some of the uncertainty associated with utilizing manure N to meet the needs of a corn crop and also reduce the use of unnecessary fertilization.

Be sure to follow the specific PSNT procedure for your state. References for procedures for several Mid-Atlantic states are listed below.

- **Maryland:**

Making Decisions for N Fertilization of Corn Using the Pre-Sidedress Soil Nitrate Test (PSNT) (Coale et al., 1996):

<http://www.agnr.umd.edu/users/agron/nutrient/Pubs/SFM-2.pdf>

- **Pennsylvania:** Pre-Sidedress Soil Nitrate Test for Corn (Beegle et al, 1999):

<http://cropsoil.psu.edu/Extension/Facts/agfact17.pdf>

- **Virginia:**

Nitrogen Soil Testing for Corn in Virginia (Evanylo et al., 1998):

<http://www.ext.vt.edu/pubs/rowcrop/418-016/418-016.html>

**Test-based
recommen-
dations for N**

Below the critical level, the PSNT can give some guidance for adjusting N recommendations. However, there is considerable scatter in the data below the critical level (Figure 7.16). It is generally agreed that no sidedress N should be recommended when the soil test value is above the critical level. When the test level is below the critical level, there are several general approaches to making recommendations:

- In the first approach, if the test value is below the critical level, the full rate of N is recommended.
- A second approach is to fall back on traditional methods of adjusting N recommendations based on field history, manure applications, previous

legumes, etc. to make an adjusted recommendation when the test value is below the critical level.

- The third approach is to use the test value as a guide for adjusting recommendations when the test is below the critical level.
- A final approach is a combination approach which uses the test value in combination with some of the traditional factors to come up with a recommendation.

Again, it is important to follow the recommendation procedure developed for your state.

Chlorophyll meter N test

An alternative to the PSNT soil test used in some states is the chlorophyll meter test. Instead of taking a soil sample, a chlorophyll meter (Minolta Spad Meter) is used to estimate the N status of the corn plants. The basic principle of this test is the same as the PSNT in that this is an in-season assessment of N status that can be used to estimate corn response to N and help improve sidedress N recommendations. Research in Pennsylvania has shown that the accuracy of the chlorophyll meter test is similar to the PSNT for predicting response to N.

This test has not been adopted in all states in the Mid-Atlantic region. Check with your local cooperative extension service to see if this test has been adopted in your state and for the specific procedures to be followed.

Figure 7.20. Chlorophyll meter nitrogen test.



The chlorophyll meter readings are taken by placing the sensor of the chlorophyll meter on the fifth leaf of the plant about 3/4 of the way towards the outside of the leaf and midway between the edge and the midrib, when the corn is at the 6 leaf stage of growth. The meter will take the reading, display the results, and keep a running average of the results. Usually, readings are

taken on 20-30 plants randomly selected across a field. After the readings are taken, the results can be averaged, and this average used to make a recommendation. The advantage of this procedure is that the results are instantaneous and there are no samples to process or analyze. The meter is relatively expensive (~\$1,500) but, when compared to the labor and analysis costs for the PSNT, it can be very cost effective.

The chlorophyll meter measures the “greenness” of the corn leaf, which is correlated to the N status of the plant. One problem with this method is that other factors can affect the “greenness” of the plant, such as hybrid differences and weather. Several approaches have been developed to compensate for this problem.

The most common approach is to establish a small high N reference area early in the season in fields to be tested with the chlorophyll meter. When it is time to run the test (6 leaf stage), readings are taken in both the high N reference area and the rest of the field. Interpretations are made by comparing the results of these two readings. This method normalizes many of the non-N-related influences.

An alternative procedure for the high N reference area approach involves taking multiple readings in a field with time. In this procedure, readings are taken at the 6 leaf stage. Based on this reading, recommendations can be made for fields that test very high or very low. Fields that do not test very high or very low are then tested again in 4-7 days. This second reading is used to make recommendations for this second group of fields. This method seems to be more practical for consultants to use than the high N reference area method.

**Late Season
Stalk Nitrate
Test**

A final N testing procedure used in the Mid-Atlantic region is the *Late Season Stalk Nitrate Test*. The Late Season Corn Stalk Nitrate Test has been shown to be a reliable end of season indicator of crop N status. It provides a good assessment of whether the crop had the right amount of N, too much N, or not enough N. This information, combined with records of N management, can be very useful for making future management decisions. Testing a few representative fields will probably be adequate to provide a good assessment of your N program.

The stalk nitrate test is performed anytime between ¼ milkline, which is just before silage harvest, to about 3 weeks after black layer formation. To collect a sample, cut 8-inch long sections of corn stalk (subsequently cut into two inch long segments) starting 6 inches above the ground. If possible, dry the samples immediately or send them to the lab as soon as possible after collection. If more than a day will pass between sampling and sending, refrigerate (don't freeze) the samples until you can send them to the lab. Keep

the samples in paper (not plastic) bags. The results of the nitrate analysis on these samples will indicate if the crop had adequate, deficient, or excess N. This information can be used to adjust future N management.

Assessing soil P levels for environmental management

The critical source area approach

As noted earlier in the chapter, soil testing for environmental protection is becoming more important. While it has been shown that soil test levels for P are related to P loss, many other factors also play important roles in determining P loss from a given field.

The most common approach to managing P in order to minimize environmental impact is the *critical source area approach* (Figure 7.17). This approach is based on integrating site specific information on sources of P (soil, fertilizer, manure, etc.) and on transport mechanisms (erosion, runoff, leaching, distance to water, etc.) to delineate areas on a landscape that have a high risk for P loss. These critical source areas are areas where a high source of P and a high potential for transport overlap. Once these areas are identified, management can be focused where it will have the greatest impact on protecting water quality.

This targeting provides maximum management flexibility for the whole farm because only a small proportion of most farms will be designated as critical source areas. For example, research in an agricultural watershed in Pennsylvania showed that 90% of the P that was getting into the water came from just 10% of the watershed. This 10% of the watershed was the critical source area. The other 90% of the watershed did not require special P management.

Figure 7.17. Critical source areas are locations where a high source of P coincides with high potential for transport of the P.

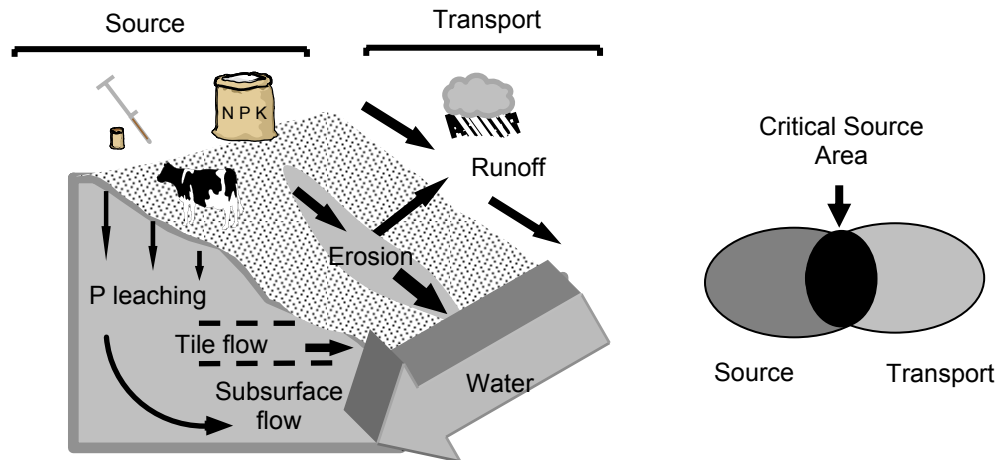

The Phosphorus Index

The Phosphorus Index (or P Index) is a tool that can be used on a farm to estimate the relative risk of P loss based on site characteristics and management. A P Index value is established by evaluating source and transport factors to determine the risk of P loss to the environment. The Pennsylvania P Index shown in Figure 7.18 is an example. The P Index evaluations used by other states in the region are very similar (Coale, 2005; Mullins et al., 2005; Sims and Leyten, 2002).

If a site has a “Low” P Index value, no specific management modifications beyond standard best management practices are required to address P. If the P Index is “High,” however, the amount of P that can be applied is limited, usually to the amount of P that will be removed by crops. If the P Index is “Very High,” no P can be applied.

One of the strengths of the P Index is that it provides options for managing P to protect the environment. If the P Index is “High,” one option is to restrict P application, but an analysis of the P Index to determine what factors gave the high result may suggest other management practices that could protect the environment without restricting P applications. For example, if erosion is high, then adopting improved erosion control practices may reduce the risk of P loss and thus, allow P applications.

Figure 7.18. The Pennsylvania Phosphorus Index (Beagle et al., 2003).

PART A: Screening Tool

User's Note: If a field has a soil test level greater than 200 ppm Mehlich-3 P or is within 150 feet of a water body, then continue with Part B.

Field ID	
Soil Test Mehlich-3 P	Greater than 200 ppm P
Contributing Distance	Less than 150 ft.

PART B: Source Factors

Soil Test	Soil Test P (ppm Mehlich-3 P)				
Soil Test Rating = 0.20 x Soil Test P (ppm Mehlich-3 P)					
Fertilizer Rate	Fertilizer P (lb P ₂ O ₅ /acre)				
Fertilizer Application Method	0.2 Placed or injected 2" or more deep	0.4 Incorporated in less than 1 week	0.6 Incorporated after 1 week or not incorporated April to October	0.8 Incorporated after 1 week or not incorporated November to March	1.0 Surface applied during frozen or snow-covered conditions
Fertilizer Rating = Fertilizer Rate x Fertilizer Application Method					
Manure Rate	Manure P (lb P ₂ O ₅ /acre)				
Manure Application Method	0.2 Placed or injected 2" or more deep	0.4 Incorporated in less than 1 week	0.6 Incorporated after 1 week or not incorporated April to October	0.8 Incorporated after 1 week or not incorporated November to March	1.0 Surface applied during frozen or snow-covered conditions
Manure P Availability	Refer to Table 1: Organic Phosphorus Source Availability Coefficients				
Manure Rating = Manure Rate x Manure Application Method x Manure P Availability					
Source Factor = Soil Test Rating + Fertilizer Rating + Manure Rating					

PART B: Transport Factors

Erosion	Soil Loss (ton/acre/year)				
Runoff Potential	0 Very Low	2 Low	4 Medium	6 High	8 Very High
Subsurface Drainage	0 None		1 Random		2** Patterned
Contributing Distance	0 > 500 ft.	2 500 to 350 ft.	4 350 to 250 ft.	6 150 to 250 ft.	8 < 150 ft.
Transport Sum = Erosion + Runoff Potential + Subsurface Drainage + Contributing Distance					
Modified Connectivity	0.7 Riparian Buffer Applies to distances < 150 ft.		1.0 Grassed Waterway OR None		1.1 Direct Connection Applies to distances > 150 ft.
Transport Factor = Transport Sum x Modified Connectivity / 22					

Phosphorus Index Value = 2 x Source Factor x Transport Factor

**Or a rapidly permeable soil near a stream

Using the P Index in nutrient management planning

The P Index is important in the nutrient management planning process. Most nutrient management plans are based initially on balancing the crop N requirements with manure N. As the plan is developed these N- based rates and management must be evaluated with the P Index.

If the P Index for the N based plan is “Low,” no additional P- based management is required. However, if the P Index is “High” or “Very High,” the N- based plan will have to be modified to address this risk of P loss either by restricting or eliminating P applications or by changing management to reduce the potential for P loss.

Plant analysis

Purpose of plant analysis

Plant analysis is the laboratory determination of elemental composition of a sample of plant tissue. This technique is most commonly used to diagnose nutritional problems related to soil fertility or to monitor the effectiveness of fertilizer practices on growing crops. Plant analysis is not a substitute for soil testing and is most effective when used in conjunction with a regular soil testing program.

Elements analyzed

The number of elements measured will depend on the laboratory analyzing the samples. The most common elements analyzed in plant tissue samples are:

- Nitrogen (N)
- Phosphorus (P)
- Potassium (K)
- Calcium (Ca)
- Magnesium (Mg)
- Iron (Fe)
- Manganese (Mn)
- Boron (B)
- Copper (Cu)
- Zinc (Zn)
- Aluminum (Al)

Other elements that may be measured either routinely or upon request include:

- Sulfur (S)

- Sodium (Na)
- Molybdenum (Mo)
- Cobalt (Co)
- Silicon (Si)
- Cadmium (Cd)
- Nickel (Ni)
- Lead (Pb)
- Chromium (Cr)
- Arsenic (As)
- Selenium (Se)

Although some of these elements are not essential for plant growth, the results may be used to identify elemental toxicities.

Sampling plant tissue for elemental analysis

Sampling in different situations

In order for plant analysis to be effective, considerable care must be given to collecting, preparing, and sending plant tissue to the laboratory for analysis. The sampling procedure will vary depending on the situation.

- For **routine monitoring of crop nutritional status**, very specific plant sampling instructions must be followed so that the results can be properly interpreted. The exact instructions for sampling will depend on the published values that will be used for interpretation.
 - For **diagnosing nutritional problems**, sampling is usually guided by the plant symptoms. Two samples should be collected: one from plants showing the symptoms and one from nearby non-symptomatic plants growing under the same conditions as the symptomatic plant.
-

When and what to sample

Proper sampling for a particular crop requires that a specific plant part be taken, such as a particular leaf, group of leaves, or portion of the plant. Instructions will also include the number of individual parts to sample, as well as the number of plants. This procedure will ensure that a sufficient quantity of plant tissue is submitted for analysis and that the collected sample is statistically representative of the area sampled.

Plant nutrient concentrations vary with position within the plant. For mobile nutrients like N, P, and K, concentrations will usually be lower in the bottom of the plant as the plant approaches deficiency. For immobile nutrients, concentrations will be lowest in the new growth as the plant approaches

deficiency. Follow the sampling instructions from the lab or person that will be interpreting the results of the analysis as closely as possible.

When no specific sampling instructions are given for a particular crop, the general rule of thumb is to sample the uppermost recently mature leaves. Young emerging leaves, older mature leaves, or seed are not usually suitable plant tissues for analysis because they do not reflect the general nutrient status of the whole plant.

For many plants, the recommended time to sample is just prior to the beginning of the reproductive stage. However, sampling earlier or even later than that may be recommended for specific plants or circumstances. Plant nutrient concentrations change throughout the life of the plant. For example, the P concentration in a healthy seedling corn plant is approximately twice the concentration found in the same plant at the reproductive stage. Thus, it is critical to follow the recommendations for time of sampling.

When sampling, do not include diseased or dead plant material in a sample. Do not sample plants or leaf tissue that has been damaged by insects, mechanically injured, or stressed extensively by cold, heat, or moisture deficiency/excess. Remove the roots from whole plant samples. Examine the roots. The presence of nematodes, insect damage, or disease damage could preclude the need to sample.

**Multiple
sampling for
diagnosing
nutritional
problems**

When a nutrient deficiency is suspected at a time other than a time recommended for routine sampling, collect two sets of samples: one from plants showing symptoms and one from normal plants growing in the immediate or adjacent areas. Take care to ensure that the two sets of plants are at approximately the same stage of growth and have been grown under the same conditions. Comparative analyses are questionable when the two sets of plants are not at the same stage of growth, have not received the same treatment, or are not the same variety or hybrid.

The best **time** to sample plants that are showing a suspected nutrient deficiency symptom is when, or shortly after, the visual symptoms appear. The best **plant part** to sample is the uppermost recently mature leaves. Be sure to take the same plant part in both samples. The plant showing the deficiency may be of different size, or at a different growth stage, than the non-affected plant, so it may be necessary to count leaves or nodes to ensure that the sample is collected from the same position on the both plants.

Interpreting plant analysis data

Introduction

Plant analysis is an effective management strategy for a sustainable soil fertility program because it provides a direct measure of nutrient concentrations and of nutrient balance within the plant. Principles and procedures used for plant analyses have evolved over many years as knowledge has increased about each essential element. The use of plant analyses has become an integral part of most agronomic research and is used as a tool for crop consultants and fertilizer dealers to monitor production fields.

Plant analysis data can be interpreted using several techniques, which include:

- *critical levels or sufficiency ranges*
 - *total nutrient accumulation*
 - *nutrient use efficiencies*
-

Critical levels and sufficiency ranges

The most common approach is to interpret plant analysis based on *critical levels* (also called *critical values* or *standard values*). This concept is the same as the critical level in soil testing. The critical level is determined by research plot calibration in the same way as for soil testing.

A critical level is that concentration below which deficiency occurs (Figure 7.19). A *sufficiency range*, which is similar to the optimum soil test range, is also designated. A plant analysis value in the sufficiency range indicates that the nutrient level is neither limiting nor too high. The effects of sampling time, variety, or hybrid, and environmental factors, such as soil moisture, temperature, and light quality and intensity may significantly affect the relationship between nutrient concentration and plant response. Thus, a defined sufficiency range may not apply to all situations or environments.

An additional category in tissue analysis is the “*Hidden Hunger*” category. This occurs where the plant is suffering from a deficiency of a nutrient that is causing reduced yield and/or quality but is not severe enough to cause clear deficiency symptoms. Plant analysis is very useful for finding hidden hunger in crops. In some situations, the levels of an element in a plant can be so high that they are toxic, so the interpretation may include a “*Toxic*” category.

Figure 7.19. Relationship between plant response (yield) and plant analysis level. This relationship is used to establish interpretation the categories for plant analysis.

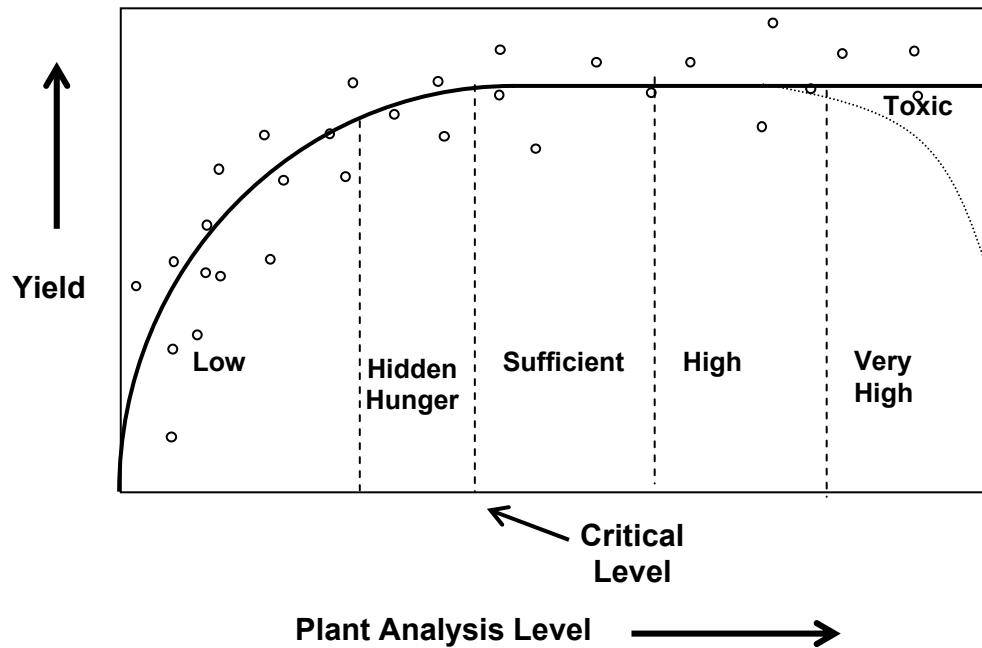

Using plant analysis data to determine timing of nutrient addition, and nutrient use efficiency

Plant analysis is useful in optimizing the timing and rates of nutrient addition. Information gained through plant analysis can be used to anticipate times when high plant nutrient concentrations must be maintained for rapid uptake and assimilation, or times when nutrients may be more vulnerable to loss. This approach identifies periods of intra-seasonal variation in plant nutrient accumulation which can be used to schedule efficient, sustainable, fertilizer applications.

Plant analysis data is used to determine relative *nutrient use efficiency* (NUE) for crop and soil management practices. If total dry matter and plant nutrient concentrations are measured, nutrient use efficiency values can be determined by dividing these values by the amount of fertilizer applied or the amount of nutrient available in the soil. These efficiency values may be used to determine the recovery of applied fertilizer and the uptake of residual nutrients.

Using plant analysis data with soil test results

Whenever possible, plant analyses should be interpreted in conjunction with a soil test from the same area to determine the actual cause of a deficiency. For example, if the plant analysis is low in K and the soil test is low in K, the interpretation is simple. The soil is deficient in K and the addition of K is necessary to correct this deficiency. In this case, either test would have

provided the information needed to make an appropriate management decision.

However, if the plant analysis is low in K but the soil is optimum or high in K, the problem is due to the inability of the plant to take up soil K, rather than a deficiency in soil K. Thus, adding more K will not likely solve the problem. Possible causes may be restricted root growth from compaction or acidity, root diseases, or root injury from herbicides or fertilizer. Either a soil test or plant analysis alone would not provide this information.

References cited

- Beegle, D., W. Gburek, P. Kleinman, A. Sharpley, and J. Weld. 2003. The Pennsylvania phosphorus index. Penn State Agricultural Research and Cooperative Extension. Available on-line at:
http://panutrientmgmt.cas.psu.edu/pdf/phosphorus_index_factsheet.pdf
- Beegle, D., R. Fox, G. Roth, and W. Piekielek. 1999. Pre-sidedress soil nitrate test for corn. Penn State Cooperative Extension. Agronomy Facts 17. Available on-line at: <http://cropsoil.psu.edu/Extension/Facts/agfact17.pdf>
- Coale, F.J. 2005. The Maryland phosphorus site index: an overview. Maryland Cooperative Extension SFM-6. Available on-line at: www.agnr.umd.edu/MCE/Publications/PDFs/SFM6.pdf
- Coale, F.J., J.J. Meisinger, P.M. Steinhilber, and P. Shipley. 1996. Making decisions for N fertilization of corn using the pre-sidedress soil nitrate test (PSNT). Maryland Cooperative Extension SFM-2. Available on-line at: <http://www.agnr.umd.edu/users/agron/nutrient/Resources/Pubs/SFM-2.pdf>
- Evanylo, G.K., and M.M. Alley. 1998. Nitrogen soil testing for corn in Virginia. Virginia Tech Cooperative Extension. Available on-line at: <http://www.ext.vt.edu/pubs/rowcrop/418-016/418-016.html>.
- Fox R.H., J.J. Meisinger, J.T. Sims, and W.P. Piekielek. 1992. Predicting N fertilizer needs for corn in humid regions: Advances in the Mid-Atlantic states. *In* B.R. Bock (ed.) Predicting N fertilizer needs for corn in humid regions. Natl. Fert. Environ. Res. Ctr., TVA, Muscle Shoals, AL.
- Mullins, G., M.L. Wolfe, J. Pease, L. Zelazny, W.L. Daniels, M. Beck, M. Brosius, A. Vincent, and D. Johns. 2005. Virginia phosphorus index, version 1.3. Virginia Polytechnic Institute and State University. Available on-line at: <http://p-index.agecon.vt.edu/>
- Sharpley, A. N., R.W. McDowell, J.L. Weld, and P.J.A. Kleinman. 2001. Assessing site vulnerability to phosphorus loss in an agricultural watershed. *J. Environ. Qual.* 30:2026-2036.
- Sims, J.T., and A.B. Leyten. 2002. The phosphorus index: a phosphorus management strategy for Delaware's agricultural soils. Delaware Cooperative Extension Service Fact Sheet ST-05.
-

Chapter 8. Commercial Fertilizers

Gregory D. Binford

Department of Plant and Soil Sciences, University of Delaware

Table of Contents

Introduction.....	189
Nitrogen fertilizers.....	189
Introduction.....	189
Urea.....	189
Ammonium nitrate.....	190
Ammonium sulfate.....	190
Non-pressure nitrogen solutions.....	190
Aqua ammonia.....	191
Anhydrous ammonia.....	191
Ammonium thiosulfate.....	191
Sulfur-coated urea.....	191
Urea-formaldehydes.....	191
IBDU.....	192
Polymer-coated urea.....	192
Phosphorus fertilizers.....	192
Introduction.....	192
Diammonium phosphate.....	192
Mono-ammonium phosphate.....	193
Ammonium polyphosphate.....	193
Concentrated superphosphate.....	193
Potassium fertilizers.....	193
Potassium chloride.....	193
Potassium sulfate.....	193
Potassium-magnesium sulfate.....	193
Potassium nitrate.....	194
Sulfur, calcium, and magnesium fertilizers.....	194
Sulfur fertilizers.....	194
Calcium fertilizers.....	194
Magnesium fertilizers.....	194
Micronutrient fertilizers.....	195
Using micronutrient fertilizers.....	195
Applying fertilizers.....	197
Solubility of fertilizers: liquid vs. dry.....	197
Fertilizer placement and application methods.....	198
Timing of application.....	199
Calculating fertilizer rates.....	200
Calculating fertilizer costs.....	201

Liming materials	202
Introduction.....	202
Calcitic and dolomitic lime.....	203
Calcium oxide or burned lime.....	203
Hydrated lime.....	204
Marl.....	204
Slags.....	204
Ground oyster shells	204
Particle size of liming materials.....	204
References for additional information	206

Introduction

Plants require optimal amounts of available nutrients for normal growth. These nutrients can come from several sources, including soil organic matter, native soil minerals, organic materials that are added to the soil (e.g., animal manures), air (e.g., legumes), and commercial fertilizers. When a soil is not capable of supplying enough nutrients to meet crop/plant requirements, commercial fertilizers can be added to supply the needed nutrients. There are numerous types of fertilizers that can be used to supply primary, secondary, or micronutrients. This chapter will provide an overview of the key issues related to commercial fertilizers.

Before using any fertilizers, it is important to understand how to read a fertilizer label. All fertilizers are labeled as %N - %P₂O₅ - %K₂O. For example, a fertilizer labeled as a 15-5-10 means that the product contains 15 percent N, 5 percent P₂O₅, and 10 percent K₂O by weight.

Nitrogen fertilizers

Introduction

Inorganic N fertilizers are produced by fixing N from the atmosphere. Natural gas is used as the energy source and is a major component of the cost of N fertilizers. The following section lists the primary N materials used by the fertilizer industry and describes some of the key characteristics of each product.

Urea

Urea [CO(NH₂)₂]:

- Fertilizer grade: 46-0-0.
- Soluble, readily available source of N.
- Dry fertilizer product.
- Produced by reacting ammonia (NH₃) with carbon dioxide under pressure at an elevated temperature.
- Contains the highest percentage of N of all dry fertilizers.
- Applying too much near germinating seeds can kill seedlings due to NH₃ release.
- Rapid hydrolysis to ammonium carbonate can cause significant N losses as NH₃ gas through volatilization when urea is applied to the surface of soil and is not incorporated:

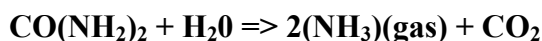

- Incorporation or injection into the soil is important to avoid volatilization losses as NH_3 gas.
 - Rainfall or irrigation (0.5 inches or more) will prevent NH_3 volatilization.
-

Ammonium nitrate

Ammonium nitrate (NH_4NO_3):

- Fertilizer grade: 34-0-0.
 - Soluble, readily available source of N.
 - Dry fertilizer product.
 - 50% of the N is present as ammonium (NH_4^+).
 - 50% of the N is present as nitrate (NO_3^-), which is the form susceptible to leaching and denitrification losses.
 - NH_3 volatilization is **not** an issue unless applied to high pH soils (i.e., >7.5).
 - Strong oxidizer that can react violently with other incompatible materials.
 - Should be stored properly to prevent risk of explosion.
 - Natural affinity to absorb moisture limits bulk storage during summer.
-

Ammonium sulfate

Ammonium sulfate [$(\text{NH}_4)_2\text{SO}_4$]:

- Fertilizer grade: 21-0-0-24S.
 - Contains 24% sulfur.
 - Soluble, readily available source of N and S.
 - 21-0-0 is dry fertilizer product.
 - NH_3 volatilization is **not** an issue unless applied to high pH soils (i.e., >7.5).
 - Also marketed in a liquid form as 8-0-0-9S.
 - Density of 8-0-0-9 is 10.14 lbs/gal @60°F; salting out temperature is 15°F.
-

Non-pressure nitrogen solutions

Non-pressure nitrogen solutions:

- Fertilizer grade: ranges from 28-0-0 to 32-0-0.
 - Soluble, readily available source of N.
 - Liquid fertilizer product that does not require pressure for storage.
 - Usually referred to as UAN (urea and ammonium nitrate).
 - Works well as herbicide carrier.
 - Prepared by dissolving urea and ammonium nitrate in water.
 - NH_3 volatilization is an issue for the urea portion of this fertilizer.
 - Density and salting out:
 - density of 28-0-0 is 10.65 lbs/gal @60°F; salting out temperature is 1°F.
 - density of 30-0-0 is 10.84 lbs/gal @60°F; salting out temperature is 14°F.
 - density of 32-0-0 is 11.06 lbs/gal @60°F; salting out temperature is 28°F.
-

Aqua ammonia	<p>Aqua ammonia (NH_4OH):</p> <ul style="list-style-type: none"> • Fertilizer grade: 20-0-0 (most common). • Density of 20-0-0 is 7.60 lbs/gal at 60°F. • Produced by dissolving NH_3 gas in water. • Liquid product that must be kept under pressure to prevent free NH_3 losses. • Must be injected into the soil to prevent NH_3 losses.
Anhydrous ammonia	<p>Anhydrous ammonia (NH_3):</p> <ul style="list-style-type: none"> • Fertilizer grade: 82-0-0. • Fertilizer with the highest analysis of N. • Stored as a liquid under pressure. • Injected into soil as a gas. • Density of 82-0-0 is 5.15 lbs/gal at 60°F. • Losses during application can occur if not applied properly. Losses are more prevalent when soils are too dry or too wet during application. • Use extreme caution during handling. Accidents can cause severe burning of skin, lungs, and eyes.
Ammonium thiosulfate	<p>Ammonium thiosulfate [$(\text{NH}_4)_2\text{S}_2\text{O}_3$]:</p> <ul style="list-style-type: none"> • Fertilizer grade: 12-0-0-26S. • Density of 12-0-0-26S is 11.1 lbs/gal at 60°F; salting out temperature is 23°F. • Readily available source of N and S. • Liquid fertilizer that does not require pressure for storage. • Can inhibit germination if placed too close to germinating seeds.
Sulfur-coated urea	<p>Sulfur-coated urea:</p> <ul style="list-style-type: none"> • Nitrogen content usually ranges from 30 to 40%. • Slow release form of N. • Urea fertilizer granule is coated with elemental S. • N release is dependent on breakdown of S coating.
Urea-formaldehydes	<p>Urea-formaldehydes (ureaforms and methylene ureas):</p> <ul style="list-style-type: none"> • Nitrogen content usually about 35 to 40%. • Slow release form of N. • Products are a mixture of urea and formaldehyde. • N release is primarily driven by microbial decomposition. • Environmental conditions influence N release by impacting microbial activity. • Ureaforms usually contain more than 60% of N as insoluble, because they contain relatively long chained molecules, while methylene ureas usually

contain 25 to 60% of N as insoluble, and contain relatively medium-chained-length molecules.

- IBDU** Isobutylidene diurea (IBDU):
- Nitrogen content usually at least 30%.
 - Slow release form of N.
 - Products are a mixture of urea and isobutyraldehyde.
 - Nitrogen release is primarily driven by hydrolysis, which is accelerated by low soil pH and high temperatures.
-

- Polymer-coated urea** Polymer-coated urea:
- Nitrogen content varies with the product.
 - Slow release form of N.
 - Release rate of N depends on the product and is influenced mainly by temperature controlled breakdown of the polymer coating.
 - Release rate of N is more precise than most slow-release products.
 - Often more expensive than other forms of N.
-

Phosphorus fertilizers

Introduction The basic ingredient for producing phosphorus (P) fertilizers is rock phosphate. Most rock phosphate comes from the mineral apatite, a calcium phosphate mineral that is mined out of the ground. The primary areas in the United States where rock phosphate is mined are in Florida, North Carolina, and several western states.

Most conventional P fertilizers are made by reacting rock phosphate with sulfuric acid to produce phosphoric acid. The phosphoric acid is then further processed to create many of the more common P fertilizers. The following section lists common P fertilizers and describes some of the key characteristics of each product.

- Diammonium phosphate** Diammonium phosphate $[(\text{NH}_4)_2\text{HPO}_4]$:
- Fertilizer grade: 18-46-0.
 - Soluble, readily available source of P and N.
 - Dry fertilizer product.
 - Initial soil reaction can produce free NH_3 , which can cause seedling injury if too much fertilizer is placed near the seed.
 - Acid-forming fertilizer.

Mono-ammonium phosphate

Monoammonium phosphate ($\text{NH}_4\text{H}_2\text{PO}_4$):

- Fertilizer grade: 11-52-0.
 - Soluble, readily available source of P and N.
 - Dry fertilizer product.
 - Acid-forming fertilizer.
-

Ammonium polyphosphate

Ammonium polyphosphate [$(\text{NH}_4)_{n+2}\text{P}_n\text{O}_{3n+1}$]:

- Fertilizer grade: 10-34-0 or 11-37-0.
 - Soluble, readily available source of P and N.
 - Liquid fertilizer product.
 - Popular source for starter fertilizers.
 - Good fertilizer source for mixing and applying with micronutrients.
 - Density of 10-34-0 is 11.65 lbs/gal at 60°F.
 - Density of 11-37-0 is 11.9 lbs/gal at 60°F.
-

Concentrated superphosphate

Concentrated superphosphate [$\text{Ca}(\text{H}_2\text{PO}_4)_2 \cdot \text{H}_2\text{O}$]:

- Fertilizer grade: 0-46-0.
 - Soluble, readily available source of P.
 - Dry fertilizer product.
 - Also called triple or treble superphosphate.
-

Potassium fertilizers

Potassium chloride

Potassium chloride (KCl):

- Most abundantly used form of potassium fertilizer.
 - Contains 60-63% K_2O .
 - Often referred to as *Muriate of Potash*.
 - Water soluble source of K.
-

Potassium sulfate

Potassium sulfate (K_2SO_4):

- Contains 50-53% K_2O , 18% S, and no more than 2.5% Cl.
 - Major use is for chloride sensitive crops.
-

Potassium-magnesium sulfate

Potassium-magnesium sulfate ($\text{K}_2\text{SO}_4 \cdot 2\text{MgSO}_4$):

- Contains about 22% K_2O , 11% Mg, 22% S, and no more than 2.5% Cl.
- Along with the K, this product is a good source of Mg and S.
- Often referred to as *Sul-Po-Mag* or *K-Mag*.
- Water soluble source of nutrients.

Potassium nitrate	Potassium nitrate (KNO_3): <ul style="list-style-type: none"> • Contains about 44% K_2O and 13% N. • All N is in the nitrate (NO_3^-) form.
--------------------------	---

Sulfur, calcium, and magnesium fertilizers

Sulfur fertilizers	<p>Sulfur is sometimes applied when other fertilizer sources are applied. For example, when ammonium sulfate is applied to supply N, plant-available S is also applied. Sulfur is taken up by plants as the sulfate ion (SO_4^{2-}), so most fertilizers that are applied in the sulfate form will be immediately available for root uptake by plants. Gypsum (CaSO_4) is less water soluble than the other sulfate fertilizers, but it can be an effective and efficient source of S, as well as Ca.</p>
---------------------------	---

Sulfur that is applied in a form other than sulfate, such as elemental S, must be oxidized by S-oxidizing bacteria in the soil before the S can be taken up by plants. The oxidation of elemental S to sulfate creates acidity, so elemental S can be used as an amendment to reduce soil pH. Elemental S is quite insoluble, so it will take several weeks to reduce soil pH. Factors that will influence the rate of oxidation of elemental S include: temperature, moisture, aeration, and particle size of the fertilizer granules.

Common types of S, Ca, and Mg fertilizers are shown in Table 8.1.

Calcium fertilizers	<p>Calcium is a nutrient that is present in soils in relatively large amounts. Most soils that are deficient in Ca are acidic, so a good liming program will usually provide adequate Ca to meet most plant needs. Gypsum (CaSO_4) can be a good source of Ca in the unusual situation that Ca is needed but lime is not needed to increase soil pH.</p>
----------------------------	--

Magnesium fertilizers	<p>The most common fertilizer source of Mg is dolomitic limestone. When a soil test shows that lime is needed to raise the soil pH and soil Mg concentrations are low to marginal, apply dolomitic limestone to raise soil pH and add Mg to the soil. Limestone has a low solubility and breaks down slowly in soils; therefore, if a quick response to Mg is needed, a more soluble source of Mg fertilizer should be considered (e.g., Epsom salts).</p>
------------------------------	--

Table 8.1. Sulfur, Ca, and Mg fertilizer materials.

Element	Name of Material	Chemical Composition	% of Element	CCE*
S	Elemental sulfur	S	100.0	none
S	Ammonium bisulfate	NH ₄ HSO ₄	17.0	none
S	Ammonium polysulfide	(NH ₄) ₂ S _x	40-50	none
S	Aluminum sulfate	Al ₂ (SO ₄) ₃	14.0	none
S	Ammonium sulfate	(NH ₄) ₂ SO ₄	24.2	none
S	Ammonium thiosulfate	(NH ₄) ₂ S ₂ O ₃ •5H ₂ O	26.0	none
S	Gypsum	CaSO ₄	18.6	none
S	K-Mag	K ₂ SO ₄ •2MgSO ₄	22.0	none
S	Potassium sulfate	K ₂ SO ₄	18.0	none
S	Magnesium sulfate	MgSO ₄	13.0	none
Ca	Calcitic limestone	CaCO ₃	32.0	85-100
Ca	Dolomitic limestone	CaMg(CO ₃) ₂	22.0	95-108
Ca	Hydrated lime	Ca(OH) ₂	45.0	120-135
Ca	Calcium oxide	CaO	55.0	150-175
Ca	Gypsum	CaSO ₄	22.3	none
Ca	Calcium nitrate	Ca(NO ₃) ₂	19.4	none
Ca	Basic slag	-----	29.0	50-70
Mg	Dolomitic limestone	CaMg(CO ₃) ₂	3-12	95-108
Mg	Epsom salts	MgSO ₄ •7H ₂ O	9.6	none
Mg	Kiserite	MgSO ₄ •H ₂ O	18.3	none
Mg	K-Mag	K ₂ SO ₄ •2MgSO ₄	11.0	none
Mg	Magnesium nitrate	Mg(NO ₃) ₂	19.0	none
Mg	Magnesia	MgO	55-60	none
Mg	Basic slag	-----	3	none

*CCE (*calcium carbonate equivalent*) = Relative neutralizing value, assuming pure calcium carbonate at 100%.

Micronutrient fertilizers

Using micronutrient fertilizers

There are many different fertilizers that are marketed as micronutrients. Usually, micronutrients are mixed with fertilizers containing N, P, and/or K. Because there are so many brands of micronutrients, it is important to read the label to determine the source of the micronutrient in the fertilizer.

The three primary classes of micronutrient sources are:

- inorganic
- synthetic chelates
- natural organic complexes

Because micronutrients are needed in such small amounts, the best method to correct a micronutrient deficiency is usually by application of the micronutrient through foliar fertilization. It is important to remember that there is a strong relationship between micronutrient availability and soil pH; therefore, micronutrient availability can be maximized by keeping the soil pH in the correct range.

Some common types of micronutrient fertilizers are shown in Table 8.2.

Table 8.2. Micronutrient fertilizer materials.

Element	Name of Material	% Element in Material
B	Borax	11.3
B	Borate 46	14.0
B	Borate 65	20.0
B	Boric acid	17.0
B	Solubor	20.0
B	Boron frits	2.0-6.0
Cu	Copper sulfate	22.5
Cu	Copper frits	variable
Cu	Copper chelates	variable
Cu	Other organics	variable
Fe	Iron sulfates	19-23
Fe	Iron oxides	69-73
Fe	Iron ammonium sulfate	14.0
Fe	Iron frits	variable
Fe	Iron chelates	5-14
Fe	Other organics	5-10
Mn	Manganese sulfates	26-28
Mn	Manganese oxides	41-68
Mn	Manganese chelates	12
Mn	Manganese chloride	17
Mn	Manganese frits	10-25
Zn	Zinc sulfates	23-35
Zn	Zinc oxides	78
Zn	Zinc carbonate	52
Zn	Zinc frits	variable
Zn	Zinc phosphate	51
Zn	Zinc chelates	9-14
Zn	Other organics	5-10
Mo	Sodium molybdate	39-41
Mo	Molybdic acid	47.5

Applying fertilizers

Solubility of fertilizers: liquid vs. dry

It is sometimes assumed that nutrients will be more available to plants if fertilizer is applied in a liquid form than if it is applied in a dry form. Research has shown, however, that there is generally no measurable difference in crop/plant response between a dry and a liquid fertilizer, as long as the two fertilizers are supplying the same amount of soluble nutrient.

For example, research has shown ammonium nitrate or urea (both dry fertilizers) will provide the same crop response as UAN (urea ammonium nitrate) solutions as long as the products are compared at the same rate of N. This should not be surprising considering the amount of water that is present in soils. The surface four inches of a silt loam soil at field capacity will normally contain more than 30,000 gallons of water. Therefore, if a dry fertilizer that is nearly 100% water soluble is applied to this soil, the nutrients in the fertilizer will quickly be dissolved in this very large amount of water.

A more important issue to consider when comparing fertilizer products is the **water solubility** of the product. If two products are being compared and one product has much greater water solubility than the other product, it would be expected that the product with the greater water solubility would provide a more rapid crop/plant response. Most common N, P, and K products are usually 90 to 100% water soluble, so little difference in response would be expected among these products, regardless of whether the products are in a liquid or dry form.

When evaluating micronutrient fertilizers, the solubility of products should be evaluated carefully because there can be a great deal of variation in the solubility of micronutrient fertilizers. If a fertilizer with low water solubility is applied to a soil, it may take several months, or even years, for the nutrient to dissolve and become available to plants.

When making decisions on the best fertilizer material to apply, the following questions should be considered:

- What is the solubility of the product?
 - Based on the available equipment, does a dry or liquid product best fit the operation?
 - What products are available from local fertilizer dealers?
 - What is the cost of those materials that are available?
-

Fertilizer placement and application methods

There are many methods that can be used for applying fertilizers. It is important to understand the relative merits of each before deciding the most cost effective and efficient method for application. For some nutrients and situations, multiple methods can be equally effective when applying fertilizers.

- One common method of application is *broadcast applications*, which simply means that the fertilizer (either dry or liquid) is spread uniformly over the surface of the soil. This method of application is generally preferred for plants that are actively growing over most (or all) of the soil surface, such as turfgrasses, pastures, alfalfa, clovers, winter wheat, and winter barley. For certain situations where nutrients (e.g., P) can be fixed or tied-up by soils, broadcast applications can be an inefficient method of application because there is much greater soil to fertilizer contact resulting in more fixation or tie-up of the nutrient.
- *Band application* is another common method of applying fertilizers. Using this method, fertilizer is applied in a concentrated band either on the soil surface or below the soil surface. One common band application method is banding starter fertilizer near the seed to supply available nutrients as the seed germinates and the plant begins to grow. For row crops, banding is generally the most efficient method for applying micronutrient fertilizers.

Banding has been shown to be the most efficient method of applying P to row crops on soils that are low or deficient in P. On soils with low available P, it has been shown that only 50% as much band-applied fertilizer is required to get the same crop response as fertilizer applied broadcast. If P is simply being applied to maintain soil test levels and a direct crop response is not expected, little difference should be expected between broadcast or banded applications.

Another common form of banding is the application of sidedress N on corn where urea ammonium nitrate (UAN) fertilizers are applied in a band that is either injected into the soil or dribbled on the soil surface, or where anhydrous NH_3 is injected. Any time that anhydrous NH_3 is applied as a fertilizer it must be injected into the soil to prevent loss of the gaseous NH_3 . The UAN fertilizers are banded when sidedressed because UAN will cause severe burning of the plant leaves if applied directly to the leaves, and because broadcast applications of urea fertilizer have a greater risk of loss through NH_3 volatilization than banded applications.

- *Foliar application* of fertilizers is an efficient method of micronutrient application. If a visual micronutrient deficiency is observed, micronutrient fertilizers should be foliar applied as soon as possible. Typically, the greater the degree of the deficiency, the less likely it is that the deficiency can be

completely corrected with foliar fertilization. If a micronutrient deficiency occurs nearly every year in the same location, it may be cost-effective to either apply a band application of micronutrient at planting or apply a preventative foliar application of fertilizer before deficiency symptoms appear. Research has shown that foliar applications of macronutrients are generally not cost effective because plants' requirements for macronutrients are greater than the amount that can be taken up through the plant leaves.

- *Fertigation* is the application of fertilizers by injecting fertilizer into irrigation water. The most common use of fertigation is in applying N to crops that require significant quantities of N (e.g., corn). It is also possible to apply micronutrient fertilizers through fertigation. Applying N fertilizers through fertigation can be one of the most efficient methods of N application because this method applies a small amount of N to an actively growing crop. Because the crop is actively growing and because relatively small amounts of N are applied (i.e., 20 to 30 lb N/acre), the loss potential of N through leaching or denitrification is minimized. Efficient application of fertilizers through fertigation, however, assumes that the irrigation system is uniformly applying water and is not applying water at rates greater than needed by the growing crop.

Timing of application

Understanding crop nutrient-use patterns and nutrient/soil interactions are important for optimizing fertilizer timing. If soils are low in P or K and have a tendency to fix these nutrients, it is important to apply these nutrients as close to planting as possible to minimize fixation. If fixation is of no concern, timing of application for P and K is generally not that important.

Timing of application can be critical for optimal efficiency of N fertilizers. Soils that are prone to leaching (i.e., coarse-textured sandy soils) or denitrification should receive applications of N just prior to rapid N uptake by the plant for optimal efficiency. For example, corn usually begins rapid uptake of N when it is 12 to 18 inches tall. Applying N as closely as possible to the time of rapid uptake will minimize the risk of N loss to the environment and maximize nutrient-use efficiency by the corn crop.

Calculating fertilizer rates

- **Calculating how much N, P, or K is in a particular fertilizer:**

A fertilizer label identifies the percent by weight of N, P₂O₅, and K₂O in the fertilizer.

– Example: 60 pounds of a 21-5-7 fertilizer would contain 12.6 pounds of N (60 X 0.21), 3 pounds of P₂O₅ (60 X 0.05), and 4.2 pounds of K₂O (60 X 0.07).

- **Calculating how much fertilizer to apply for a specific amount of nutrient:**

The basic formula for calculating how much fertilizer to apply to a given area for a specific amount of nutrient is the following:

$$\text{Amount of fertilizer} = (\text{Amount of nutrient needed} \div \text{Percent nutrient in the fertilizer}).$$

– Example 1:

How much 34-0-0 is needed to apply 30 pounds of N?

It would take 88 pounds (30 ÷ 0.34) of 34-0-0 to apply 30 pounds of N.

– Example 2:

If 15-8-10 was used to apply 45 pounds of N, how much P₂O₅ and K₂O would be applied with this application?

It would take 300 pounds (45 ÷ 0.15) of 15-8-10 to apply 45 pounds of N. Therefore, a 300 pound application of 15-8-10 would supply 24 pounds of P₂O₅ (300 X 0.08) and 30 pounds of K₂O (300 X 0.10).

- **Calculating rates of liquid fertilizers:**

When doing fertilizer calculations with liquid fertilizers, the calculations are similar but the density of the liquid fertilizer must be known before doing any calculations.

– Example: If a jug contains 2 gallons of a 9-18-6 liquid fertilizer that weighs 11.1 pounds per gallon, how much N, P₂O₅, and K₂O would be in this jug of fertilizer?

First, calculate how much fertilizer is present in the 2 gallons. There would be 22.2 pounds of fertilizer (11.1 lb/gal X 2 gal). So, there would be 2 pounds of N (22.2 X 0.09), 4 pounds of P₂O₅ (22.2 X 0.18), and 1.3 pounds of K₂O (22.2 X 0.06) in this 2 gallon container of fertilizer.

• **Calculating the amount of fertilizer needed for a specific area of land:**

– Pounds per acre:

For example, how much urea (46-0-0) is needed to apply 135 pounds of N to 30 acres of land (1 acre = 43,560 square feet)?

Begin by calculating how much urea is needed to provide 135 pounds of N per acre. This would be 293.5 pounds ($135 \div 0.46$). So, the total urea needed for 30 acres would be 8,804 pounds (293.5×30) or 4.4 tons (there are 2,000 pounds in a ton).

– Pounds per 1000 square feet:

For turfgrasses or horticultural crops, fertilizer is often applied in pounds of nutrient per 1000 square feet. For example, how much ammonium sulfate (21-0-0) is needed to supply 1 lb N per 1000 square feet to a lawn that is 7,500 square feet?

It would take 4.76 pounds of ammonium sulfate to supply 1 lb N ($1 \div 0.21$). Therefore, it would take 35.7 pounds ($(7,500 \div 1000) \times 4.76$) of ammonium sulfate for this lawn.

**Calculating
fertilizer costs**

Bulk fertilizer is often sold by the ton; therefore, it is important to know how to convert the cost per ton to the cost per unit of a specific nutrient so that price comparisons can be made between various fertilizer choices.

– Example 1:

Urea (46-0-0) is currently selling for \$340 per ton, ammonium sulfate (21-0-0) is selling for \$240 per ton, and UAN (30-0-0) is selling for \$204 per ton. What is the price of each of these fertilizers when priced per unit of N?

There are 920 pounds (2000×0.46) of N in a ton of urea, 420 pounds (2000×0.21) of N in a ton of ammonium sulfate, and 600 pounds (2000×0.3) of N in a ton of this UAN. This means that the cost per pound of N is \$0.37 for urea ($\$340 \div 920$), \$0.57 for ammonium sulfate ($\$240 \div 420$), and \$0.34 for UAN ($\$204 \div 600$).

– Example 2:

Diammonium phosphate (18-46-0) is currently selling for \$280 per ton. What is the cost per pound of N and per pound of P_2O_5 ?

A ton of 18-46-0 contains 360 pounds of N (2000×0.18) and 920 pounds of P_2O_5 (2000×0.46); therefore, the cost per pound of N is \$0.78 ($\$280 \div 360$), while the cost per pound of P_2O_5 is \$0.30 ($\$280 \div 920$). This

example demonstrates that if N is the only nutrient needed, diammonium phosphate would be an expensive fertilizer choice. However, if P and N are both needed by the crop, then diammonium phosphate would be an excellent fertilizer choice because the P and some of the N required by the crop would be supplied by the same fertilizer. Diammonium phosphate is typically used to meet the P need rather than the N need of a crop. The N supplied by diammonium phosphate application is then deducted from the crop's N requirement.

– Example 3:

If liquid ammonium sulfate (8-0-0-9) is selling for \$90 per ton and UAN (30-0-0) is selling for \$204 per ton, what is the cost per gallon of each of these products knowing that 8-0-0-9 weighs 10.14 pounds per gallon and 30-0-0 weighs 10.84 pounds per gallon?

One ton of 8-0-0-9 would consist of 197.2 gallons ($2000 \div 10.14$), while a ton of 30-0-0 would consist of 184.5 gallons ($2000 \div 10.84$); so, one gallon of 8-0-0-9 ($\$90 \div 197.2$) would cost \$0.46 and one gallon of 30-0-0 would cost \$1.11 ($\$204 \div 184.5$). The cost per pound of N for each of these products would be \$0.57 [$0.46 \div (10.14 \text{ lb/gal} \times 0.08)$] for the 8-0-0-9 and \$0.34 [$\$1.11 \div (10.84 \text{ lb/gal} \times 0.3)$] for the 30-0-0.

Liming materials

Introduction

Maintaining soil pH in the proper range is important to the optimal growth of plants. If soil pH drops below about 5.5, aluminum begins to become soluble in soils. The amount of soluble aluminum increases dramatically as the soil pH continues to drop. Many plants do not grow well when large amounts of aluminum are present in the soil solution, so lime must be added to these soils to prevent soil pH from getting too low. An understanding of liming materials is important when deciding the type of lime to use.

Limestone is a naturally occurring mineral resulting from the deposition and compression of the skeletal remains of marine organisms (e.g., coral, shellfish, etc.), and it contains high amounts of calcium and magnesium carbonates. Because limestone is a naturally occurring mineral, there are varying degrees of purity and chemical composition. Pure calcium carbonate (CaCO_3) has been assigned an arbitrary index of 100 to define its neutralizing value. All liming materials are then compared to pure CaCO_3 and rated on their neutralizing ability relative to pure CaCO_3 . This rating, referred to as the *calcium carbonate equivalency* (CCE), is assigned to all liming materials. A CCE greater than 100 indicates that the material is capable of neutralizing more acidity on a weight basis than pure CaCO_3 , and vice versa.

The property that distinguishes lime from other calcium or magnesium bearing materials is that lime contains calcium and/or magnesium in forms that, when dissolved, will neutralize acidity. Lime components which reduce acidity are the carbonates contained in limestone and marl, the oxides contained in burned lime, and the hydroxides found in slaked lime. Not all materials that contain calcium and magnesium can be used for liming purposes. For example, calcium and magnesium sulfates and chlorides will supply calcium and magnesium, but will not reduce soil acidity.

The carbonates, oxides, and hydroxides of calcium and magnesium are only sparingly soluble in water. These materials require soil acidity in order to react, and the reaction is fairly slow due to their low solubility. Burned lime and hydrated lime are highly reactive and react quickly with soil acidity. To obtain the greatest benefit from these materials, especially at higher rates of application, they should be thoroughly mixed with the soil by disking and/or plowing.

Calcitic and dolomitic lime

Calcitic and dolomitic limes are made by grinding or crushing mined limestone rock to a certain fineness. The degree of fineness must be specified when sold. In order to be useful as an agricultural liming material, crushed limestone must react with soil acids within a reasonable length of time. The rate of reaction or dissolution of crushed limestone is largely determined by its fineness or mesh size.

Calcitic lime reacts somewhat faster than dolomitic lime of the same mesh size. Dolomitic lime contains both magnesium and calcium, whereas calcitic lime contains mainly calcium. The CCE of these limes is similar (Table 8.1).

Acid soils that are deficient in magnesium should be treated with dolomitic limestone. Calcitic lime should be used on acid soils where the ratio of soil test calcium to magnesium is less than 1.4. Either dolomitic or calcitic lime may be used in all other situations.

Calcium oxide or burned lime

Calcium oxide, or burned lime, is made by roasting crushed limestone in an oven or furnace. This process changes the chemical form of Ca from a carbonate to an oxide. Burned lime is also known as *unslaked* or *quick lime*. The CCE of burned lime depends on the purity of the limestone from which it is made but usually ranges from 150 to 175. No other liming material has such a high neutralization value. Approximately 1,140 pounds of burned lime with a CCE of 175 is equivalent to 2,000 pounds of calcitic lime with a CCE of 100.

Burned lime is usually sold in bags because of its powdery nature, unpleasant

handling properties, and reactivity with moisture in the air. This liming material neutralizes soil acids rapidly but is somewhat difficult to mix with the soil. Thorough mixing at the time of application is necessary due to a tendency for burned lime to absorb moisture, resulting in the formation of lime granules or aggregates.

Hydrated lime Hydrated lime is calcium hydroxide but is usually called *slaked* or *builders' lime*. This type of lime is made by reacting burned lime with water and drying the resulting calcium hydroxide. Hydrated lime is similar to burned lime in that it is powdery, reacts quickly, and is unpleasant to handle. The CCE ranges from 110 to 135 depending on the purity of the burned lime.

Marl Marls are found in beds, mixed with earthen materials, in the form of calcium carbonate. These calcium deposits are often found in the Eastern or Coastal Plain Region of Virginia, limestone valleys in the Appalachian Region, and other Atlantic Coast states. Their usefulness as a liming material depends on the CCE, which usually ranges from 70 to 90, and the cost of processing into usable material. Marls are usually low in magnesium, and their reaction within the soil is similar to calcitic lime.

Slags Slag is a by-product of the steel industry and consists primarily of calcium silicate minerals. Slags can make a good liming material, but most slags have a lower CCE than calcitic lime, requiring the use of a higher rate.

One important note about slags is that they can sometimes contain significant quantities of heavy metals. Thus, it is important to know the composition of the slag before using the material as a soil amendment.

Ground oyster shells Oyster shells and other sea shells are composed primarily of calcium carbonate. These materials can work well as liming materials. As with any lime, the fineness of the material and the CCE will determine the appropriate rate to apply to a soil for proper pH adjustment.

Particle size of liming materials Fineness, or mesh size, of applied lime is the main factor that influences the rate of reaction. All of the lime applied does not need to react with the soil immediately to be of maximum value. The coarser mesh sizes dissolve over a longer period of time and in so doing, tend to maintain soil pH.

A certain amount of lime should be sufficiently fine (pass an 80-mesh sieve) to react rapidly with the soil acidity. Part of the lime should be sufficiently fine (about 40 to 60 mesh) to react within one to two years, and the remainder

of the lime should be large enough (about 20 mesh) to react in a period of two to three years. For a liming material to react in this manner, it must be composed of lime particles of different mesh sizes. Research has shown that limestone that is pulverized to 100 mesh, or finer, will react rapidly with soil acids. On the other hand, 10- to 20-mesh limestone dissolves very slowly and, therefore, is only slightly effective in reducing soil acidity.

Burned and hydrated limes have a much finer mesh than the ground limestones and are therefore quicker acting. All lime particles in these materials are 100 mesh or finer. The quick-acting characteristics of these lime materials can be an advantage in certain situations.

References for additional information

Note: Although these references are not cited specifically in this chapter, information obtained from them was helpful in writing the chapter.

Allen, S.E. 1984. Slow-release nitrogen fertilizers. p. 195-206. *In* R.D. Hauck (ed.) Nitrogen in crop production. American Society of Agronomy, Madison, WI.

Barber, S.A., R.D. Munson, and W.B. Dancy. 1985. Production, marketing, and use of potassium fertilizers. p. 377-410. *In* O.P. Engelstad (ed.) Fertilizer technology and use. Soil Science Society of America, Madison, WI.

Boswell, F.C., J.J. Meisinger, and N.L. Case. 1985. Production, marketing, and use of nitrogen fertilizers. p. 229-292. *In* O.P. Engelstad (ed.) Fertilizer technology and use. Soil Science Society of America, Madison, WI.

Engelstad, O.P., and G.L. Terman. 1980. Agronomic effectiveness of phosphate fertilizers. p. 311-332. *In* F.E. Khasawneh et al. (ed.) The role of phosphorus in agriculture. American Society of Agronomy, Madison, WI.

Fluid Fertilizer Manual. 1994. Vol. 1 and 2. Fluid Fertilizer Foundation, 2805 Claflin Road, Suite 200. Manhattan, KS.

Hauck, R.D. 1985. Slow-release and bioinhibitor-amended nitrogen fertilizers. p. 293-322. *In* O.P. Engelstad (ed.) Fertilizer technology and use. Soil Science Society of America, Madison, WI.

Havlin, J.L., J.D. Beaton, S.L. Tisdale, and W.L. Nelson. 1999. Soil fertility and fertilizers: an introduction to nutrient management. Prentice Hall, Upper Saddle River, N.J.

IMC Fertilizer Inc. 1992. Efficient fertilizer use - fertilizing for maximum profit. DBFT2-001C. IMC Fertilizer, Inc. Muldelein, IL.

Russel, D.A. 1984. Conventional nitrogen fertilizers. p. 183-194. *In* R.D. Hauck (ed.) Nitrogen in crop production. American Society of Agronomy, Madison, WI.

Sartain, J.B. 2002. Food for turf: Slow-release nitrogen. Grounds Maintenance, April 1, 2002. PRIMEDIA Business Magazines and Media, Inc. Available on-line at: http://www.grounds-mag.com/mag/grounds_maintenance_food_turf_slowrelease/

Chapter 9. Manure as a Nutrient Source

David J. Hansen

Department of Plant and Soil Sciences, University of Delaware

Table of Contents

Introduction.....	208
Manure production and composition	208
Quantity of manure produced	208
Variation in manure NPK content among species	208
Improving the digestibility of P	210
Other nutrients in manure	210
Manure sampling and testing	212
Detailed sampling and handling procedures	212
Manure storage and handling.....	213
Nutrient loss	213
Estimating nutrient loss during storage.....	214
Land application of manure	216
Introduction.....	216
Availability of manure nutrients to plants	216
Forms of N in manure	216
Estimating N mineralization rate	217
Sources of volatilizable N.....	218
Effect of soil pH on N volatilization.....	218
Effect of incorporation on N volatilization.....	219
Calculating plant-available N (PAN).....	220
Equipment calibration.....	221
Calibrating with the tarp method	221
Calibrating with the swath and distance method	222
Calibrating with the loads-per-field method	223
References cited.....	224

Introduction

Manure is an unavoidable byproduct of animal production. Manure can be a valuable source of nutrients for crop production when properly managed; however, improper management of manure can result in environmental degradation, damage to crops, and conflicts with neighbors and the public because of odors, pests, or other nuisances.

Proper management of manure must consider all aspects of the operation, including how and where manure is generated, how it is stored, and how it is ultimately used. Although there are various alternative uses for manure (e.g., biogas generation), this chapter will address the issues of manure production, storage, and land application for managing manure as a nutrient source for crops.

Manure production and composition

Quantity of manure produced

The quantity (volume or mass) of manure produced and its nutrient content are the most critical factors that govern its use as a nutrient source. The quantity of manure produced varies considerably among species because of differences in animal diets and metabolism and within species due primarily to differences in management (e.g. bedding, feed source, etc.). Estimates of dry and semi-solid manure production by species have been summarized by Tetra Tech, Inc. (Table 9.1).

Variation in manure NPK content among species

Animals are relatively inefficient in their utilization of N, P, and K from feed, with more than 50% commonly passing through to the feces. These nutrients may end up in the manure and, in the case of N, be lost to the atmosphere. In addition to variability in feed conversion efficiency, the amount and type of bedding (if any) will also influence the nutrient content of the material.

As might be expected, the quantity of nutrients in the manure varies considerably by species (Table 9.2). For example, broiler litter may contain four to five times as much N, and ten times as much P, as horse manure.

Table 9.1. Annual manure production estimates for various species (Tetra Tech, Inc., 2004).

	Animals per AU^a	Annual manure production per AU
	-1000 lbs-	---tons---
Beef cattle	1.00	11.50
Dairy cattle	0.74	15.24
Swine (breeders)	2.67	6.11
Swine (other)	9.09	14.69
Hens (laying)	250.00	11.45
Pullets (over 3 months)	250.00	8.32
Pullets (under 3 months)	455.00	8.32
Broilers	455.00	14.97
Turkey (slaughter)	67.00	8.18

^aAU = animal unit

Table 9.2. Nutrient content of various types of manure.

Manure Type	Nitrogen (total)	Phosphorus (P₂O₅)	Potassium (K₂O)
	-----lb / ton -----		
Broiler litter^b	59	63	40
Turkey (fresh)^a	27	25	12
Layer^a	35	42	28
Horse^b	9	6	11
	-----lb / 1000 gal -----		
Swine^b	40	37	23
Dairy^b	28	19	25

^a Zublena et al., 1990.

^b Bandel, 1990.

Table 9.3. Poultry litter moisture and nutrient values from 2,054 samples in Arkansas (Van Devender et al., 2004).

	Moisture Content	Nitrogen (Total)	Phosphorus (P₂O₅)	Potassium (K₂O)
	-----%-----	-----lb / ton -----		
Minimum	2	22	18	23
Maximum	47	98	96	80
Mean	23	60	58	52

Improving the digestibility of P

Deviations from the nutrient content values listed above may occur for a number of reasons. One of the most important reasons is diet manipulation. Cereal grains (such as corn and soybeans) are major feed ingredients in poultry and swine diets (National Research Council, 1994). Approximately two-thirds of the P in these grains is in the form phytic acid, or phytate, that is poorly-digested by non-ruminants. This results in inefficient use of most of the grain-P, which subsequently passes through the animal in the manure. Because of this poor utilization, non-ruminant diets commonly are supplemented with more digestible forms of P, such as calcium phosphate (Angel et al., 2001).

One technique to increase the digestibility of P in feed grains is to add phytase to the feed. Phytase is an enzyme that helps the birds utilize more of the “indigestible” P, which reduces the need for supplemental P. Research has shown reductions in P excretions of 25 to 50% when phytase is added to poultry or swine diets and supplemental P (e.g., calcium phosphate) is reduced (Maguire et al., 2005; Nahm, 2002). Hansen et al. (2005) found that the recent adoption of phytase has lowered the P content of poultry litter in Delaware by 30 to 40% compared to traditional values.

Other nutrients in manure

Manure is usually managed to provide the three major plant nutrients (N, P, and K). However, varying amounts of other essential elements, including Ca, S, B, Mg, Mn, Cu, Mo, Fe, Na, and Zn, enhance the value of manure as a balanced nutrient source. Tables 9.4 and 9.5 contain “typical” concentrations of secondary and micro-nutrients of various poultry and swine manures, respectively.

Table 9.4. Typical content of secondary and micronutrients in poultry manures (Zublena et al., 1990).

Manure Type	Ca	Mg	S	Na	Fe	Mn	B	Mo	Zn	Cu
-----lbs/ton-----										
Layer										
Undercage scraped	43.0	6.1	7.1	4.5	0.5	0.27	0.05	<0.01	0.32	0.04
Highrise stored	86.0	6.0	8.8	5.0	1.8	0.52	0.05	<0.01	0.37	0.04
Broiler litter										
Broiler house	41.0	8.0	15.0	13.0	1.3	0.67	0.05	<0.01	0.63	0.45
Roaster house	43.0	8.5	14.0	13.0	1.6	0.74	0.05	<0.01	0.68	0.51
Breeder house	94.0	6.8	8.5	8.6	1.3	0.57	0.04	<0.01	0.52	0.21
Stockpiled	54.0	8.0	12.0	6.2	1.5	0.59	0.04	<0.01	0.55	0.27
Turkey litter										
Brooder house	28.0	5.7	7.6	5.9	1.4	0.52	0.05	<0.01	0.46	0.36
Grower house	42.0	7.0	10.0	8.4	1.3	0.65	0.05	<0.01	0.64	0.51
Stockpiled	42.0	6.8	9.5	6.4	1.5	0.62	0.05	<0.01	0.56	0.34
-----lbs/1000 gallons-----										
Layer										
Liquid slurry	35.0	6.8	8.2	5.3	2.9	0.42	0.04	0.02	0.43	0.08
Lagoon sludge	71.0	7.2	12.0	4.2	2.2	2.3	0.08	0.01	0.80	0.14
-----lbs/acre-inch-----										
Layer										
Lagoon liquid	25.0	7.4	52.0	51.0	2.0	0.24	0.4	0.02	0.70	0.19

Table 9.5. Typical content of secondary and micronutrients in swine manures (Zublena et al., 1990).

Manure Type	Ca	Mg	S	Na	Fe	Mn	B	Mo	Zn	Cu
-----lbs/ton-----										
Fresh	7.9	1.7	1.8	1.6	0.39	0.04	0.07	<0.01	0.12	0.03
Paved lot scraped	12.0	2.3	2.2	1.6	1.03	0.19	0.02	<0.01	0.35	0.15
-----lbs/1000 gallons-----										
Liquid slurry	8.6	2.9	4.7	3.7	0.7	0.15	0.07	<0.01	0.39	0.11
Lagoon sludge	15.8	4.5	8.3	2.9	1.8	0.28	0.02	0.01	0.67	0.23
-----lbs/acre-inch-----										
Lagoon liquid	25.5	8.3	10.0	57.7	2.4	0.34	0.18	<0.01	1.50	0.30

Manure sampling and testing

It is important to realize that actual manure nutrient content can be dramatically different from typical values. Testing of manure from specific operations is critical to accurately assess nutrient concentrations for the purpose of calculating manure application rates to supply crop nutrient needs.

A manure sample must be collected for laboratory analysis in order to determine the exact nutrient content. Proper collection of this sample is critical to ensure that it accurately represents the manure to be used.

Detailed sampling and handling procedures

In practice, it is difficult to obtain a truly representative sample because of the inherent variability in manure within a stockpile, a lagoon, or other storage facility. The following guidelines (adapted from Hermanson, 1996) will help to assure the best sample possible:

- **Semi-solid lot manure:**

- Scraped directly from lot into spreader:
 - a) Collect about 2 lbs of manure using nonmetallic collectors from different locations within a loaded spreader.
- From storage:
 - a) Collect manure using nonmetallic collectors from under the surface crust while avoiding bedding materials.

- **Liquid manure slurry:**

- From under-slotted-floor pit:
 - a) Extend a 1/2-in nonmetallic conduit open on both ends into manure to pit floor.
 - b) Seal upper end of conduit by placing a thumb over open end to trap manure, remove and empty slurry into plastic bucket or nonmetallic container.
 - c) Take subsamples totaling at least 1 quart from 5 or more locations.
- From exterior storage basin or tank:
 - a) Ensure that manure has been well mixed with a liquid manure chopper-agitator pump or propeller agitator.
 - b) Take subsamples from 5 pit locations from agitator pump or from manure spreader, and place in a plastic bucket.

- **Lagoon liquid:**

- Recycled liquid:
 - a) Collect recycled lagoon liquid from inflow pipe to flush tanks in a nonmetallic sample container.
- From lagoon:
 - a) Place a small bottle (1/2 pint or less) on end of 10 to 15 ft pole.
 - b) Extend bottle 10 to 15 ft from bank edge.
 - c) Brush away floating scum or debris.

- d) Submerge bottle within 1 ft of liquid surface.
- e) Empty into a plastic bucket, repeat 5 times around lagoon, and mix.

• **Broiler or turkey litter:**

– House litter:

- a) Visually inspect litter for areas of varying quality (e.g., areas around feeders and waterers), and estimate percent of floor surface in each area.
- b) Take 5 litter subsamples at representative locations representative of overall litter characteristics.
- c) At each location, collect litter from a 6-in by 6-in area to earth floor and place in a plastic bucket.
- d) Mix the 5 subsamples in the bucket transfer to a nonmetallic sample container, such as a 1-gallon freezer bag, and seal.

– From stockpile:

- a) Collect subsamples from 5 locations at least 18 in into pile.
- b) Mix, transfer 2 to 3 lbs to nonmetallic sample container, and seal.

Manure samples should be either refrigerated or sent immediately to the testing laboratory. Glass containers should never be used because pressure from developing gases may fracture the glass.

Manure storage and handling

Nutrient loss

The nutrient content of manure, particularly nitrogen, can change during storage; therefore, sampling and analysis should be performed as close to the time of application as possible. Changes in nutrient content can occur due to dilution (e.g., rainwater entering a liquid storage system), settling (e.g., phosphorus precipitation and accumulation in lagoon sludge), or gaseous loss (e.g., nitrogen volatilization).

Some typical storage-related losses of N, P, and K for various manure systems are presented in Table 9.6. The losses were calculated by subtracting the nutrient contents after storage from “as-excreted” values so they include both storage and handling losses. Handling losses likely account for a consistent, but small, amount of nutrient loss.

Except for lagoons, losses of P and K during storage are relatively low and are likely due more to handling than actual storage. Large losses occur in lagoon systems as solids settle from the slurry to the bottom of the lagoon. By contrast, N losses during storage can range from 15% to as much as 90%. Note that the ranges can be fairly broad and actual losses may exceed the tabulated ranges due to differences in management, weather, mitigation strategies, etc.

Table 9.6. Typical manure losses during handling and storage (Fulhage and Pfost, 2002).

Manure System	Nitrogen	Phosphorus (P ₂ O ₅)	Potassium (K ₂ O)
	-----percent lost-----		
Solid			
Daily scrape and haul	20-35	5-15	5-15
Manure pack	20-40	10-20	10-20
Poultry, deep pit or litter	25-50	5-15	5-15
Solids on open lot			
Scrape once/year	40-55	20-40	30-50
Daily scrape and haul	20-35	10-20	15-25
Separated solids, 90 days storage	30	10-20	10-20
Liquid (slurry)			
Anaerobic pit	15-30	5-20	5-20
Aboveground storage	10-30	5-15	5-15
Manure basin or runoff pond, 120-180 days storage	20-40	5-50	5-50
Liquid- lagoon	70-85	50-80	30-80
Lagoon, 365 days	90	50-80	30-80

Estimating nutrient loss during storage

Nutrient losses during storage are commonly estimated with the use of a standard loss factor for each type of storage (Table 9.7). Such calculations can be helpful for planning purposes, but it is best to test the manure before using it to supply plant-available nutrients.

Note: Determining the storage needs of the various types of operations is beyond the scope of this manual; however, there are some general factors that should be considered in essentially any situation where manure is stored before being applied to land. These considerations include the characteristics of the land (i.e., slope, vegetation, soil type, proximity to water) and the type of manure to be used (i.e. liquid, semi-solid, or solid).

Information regarding siting and sizing of storage facilities can be found in the Natural Resources Conservation Service (NRCS) Field Office Technical Guide available in electronic form for individual states at: <http://www.nrcs.usda.gov/technical/efotg/>.

Table 9.7. Estimating annual nutrient availability after losses from open lot, storage or lagoon^a. Enter total manure nutrients produced (from Table 9.2) in columns 2, 5, and 8 and multiply by the relevant factor for your storage or management system.

Manure Storage/ Treatment System	Nitrogen			Phosphorus (P ₂ O ₅)			Potassium (K ₂ O)		
	N Produced	Factor ^b	Available N	P Produced	Factor ^b	Available P	K Produced	Factor ^b	Available K
<i>Example: poultry manure on sawdust; per ton (from Table 9.3)</i>	60	* 0.50	30	58	* 1.0	58	52	* 1.0	52
Open lot or feedlot		* 0.50			* 0.95			* 0.70	
Storage (slurry manure, bottom loaded storage)		* 0.85			* 1.0			* 1.0	
Storage (liquid manure, top loaded storage)		* 0.70			* 1.0			* 1.0	
Storage (pit beneath slatted floor)		* 0.75			* 1.0			* 1.0	
Poultry manure in pit beneath slatted floor		* 0.85			* 1.0			* 1.0	
Poultry manure on shavings or sawdust held in house		* 0.50			* 1.0			* 1.0	
1-Cell anaerobic treatment lagoon		* 0.20			* 0.35			* 0.65	
Multi-cell anaerobic treatment lagoon		* 0.10			* 0.35			* 0.65	

^a Source: <http://ianrpubs.unl.edu/wastemgt/graphics/g1334t1.pdf>

^b Multiplication factor: the portion of nutrients retained in the manure or effluent.

Land application of manure

Introduction

Most manure generated in the Mid-Atlantic region is applied to soils as a nutrient source for crop production. Manure has also been found to improve certain soil properties, including soil structure, water-holding capacity, and populations of beneficial organisms.

It is critical both from crop production and environmental perspectives that the application rates provide adequate nutrient levels while avoiding the application of excess nutrients that can leave the field via runoff or leaching. Overapplication of manure has been linked to environmental problems, including eutrophication.

Manure is usually managed to provide the three major plant nutrients: N, P, and K. The goal of proper manure management for crop production is to apply the manure using appropriate methods and rates to maximize the amount of land-applied nutrients that are taken up by plants.

Availability of manure nutrients to plants

The plant-availability of the P and K in manure is commonly assumed to be similar to the availability of these nutrients in commercial fertilizer because most of the P and K in land-applied manure are present in inorganic forms. Determining the availability of P and K is a relatively simple matter of determining the P and K content of the manure. By contrast, determining the availability of N in manure is more complicated.

Forms of N in manure

Nitrogen in manures is found in two forms: organic and inorganic (Figure 9.1). Organic N is the fraction in dead plant and animal material and is found primarily in amine groups ($-NH_2$) and uric acid. Inorganic manure N can be either ammonium (NH_4^+) or nitrate (NO_3^-). The most common form of inorganic N in manure is ammonium, which is specified in most laboratory analyses.

Figure 9.1. Partial N cycle showing the forms and transformations of nitrogen in manure.

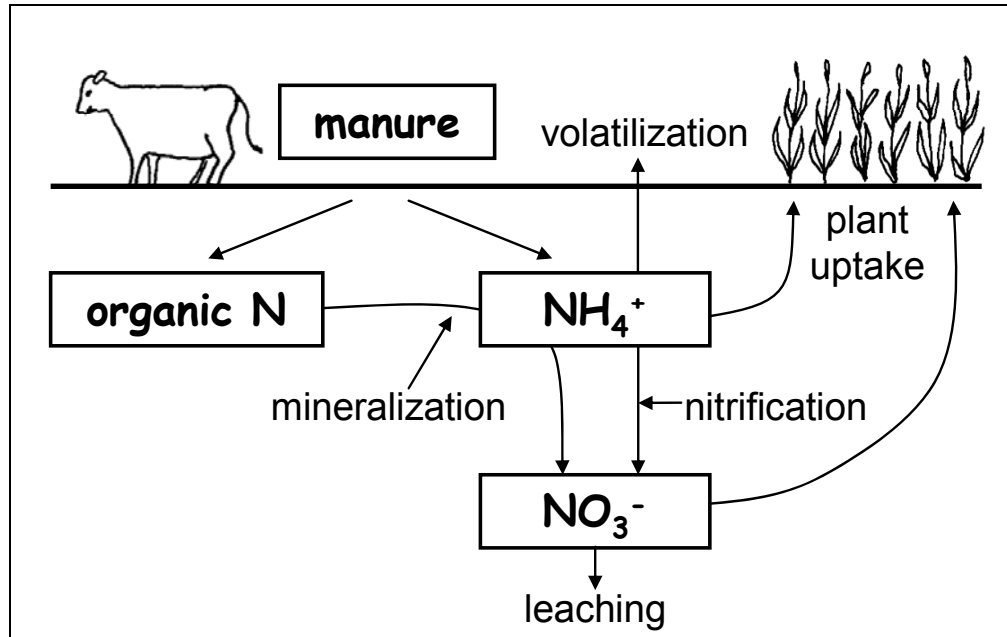

Estimating N mineralization rate

The inorganic fraction, which can comprise 20 to 65% of the total quantity of N in manure (Table 9.8), is considered immediately available to plants. The organic fraction must first be converted to inorganic N: a process termed *mineralization*. The rate at which the organic N is mineralized is highly variable and influenced by factors such as temperature, moisture, and C:N ratio of the manure. Despite this variability in mineralization rate, researchers have adopted some general mineralization factors that are commonly employed to estimate N availability for various types of manure during the season following the application (Table 9.9). These factors represent the percentages of the organic fraction that are expected to become available to plants during the first year after application of manure.

Table 9.8. Average percentage of forms of nitrogen in different types of manure in Virginia (Virginia Department of Conservation and Recreation, 1993).

Manure type	Organic N	Inorganic N (NH ₄ ⁺)
	----- % -----	
Dry poultry	77	23
Liquid poultry	36	64
Semi-solid dairy	70	30
Liquid dairy	58	42
Semi-solid beef	80	20
Swine lagoon	47	53
Mixed swine	35	65

Table 9.9. Fraction of organic N mineralized from various manure types and application scenarios in the year of application. (Virginia Department of Conservation and Recreation, 2005.)

Manure type	Spring or early fall applied ^a	Winter topdress or spring residual ^b	Perennial grass
	----- N mineralization factor -----		
Dairy or beef	0.35	0.20/0.15	0.35
Swine	0.50	0.25/0.25	0.50
Poultry	0.60	0.30/0.30	0.60

^a Factors for manure applied in spring for summer annual crops or in early fall for small grain crops.

^b Factors for manure applied in early winter/available in spring.

Sources of volatilizable N

Volatilization is the loss of N as ammonia gas (NH₃). There are two major pathways for this loss in agriculture: conversion of ammonium-N (NH₄⁺-N) to NH₃ and the conversion of urea (CO(NH₂)₂) to NH₃. Urea is a nitrogen-containing compound that is readily converted to ammonia upon catalysis by the ubiquitous enzyme urease via the following reaction:



Effect of soil pH on N volatilization

The most important factor influencing nitrogen volatilization of reduced inorganic N (i.e., ammonium and ammonia) in manure is pH (Fig. 9.2). Nearly all of these N forms are present as ammonium at pH levels typically encountered in Mid-Atlantic soils (i.e., <6.5). The percentage of ammonia

increases and volatilization losses are more likely to occur as pH rises. This equilibrium is typically shifted toward ammonia in freshly excreted manures, which have higher pH values than soil.

Figure 9.2. The $\text{NH}_3/\text{NH}_4^+$ (ammonia to ammonium) ratio as a function of pH (adapted from Gay and Knowlton, 2005).

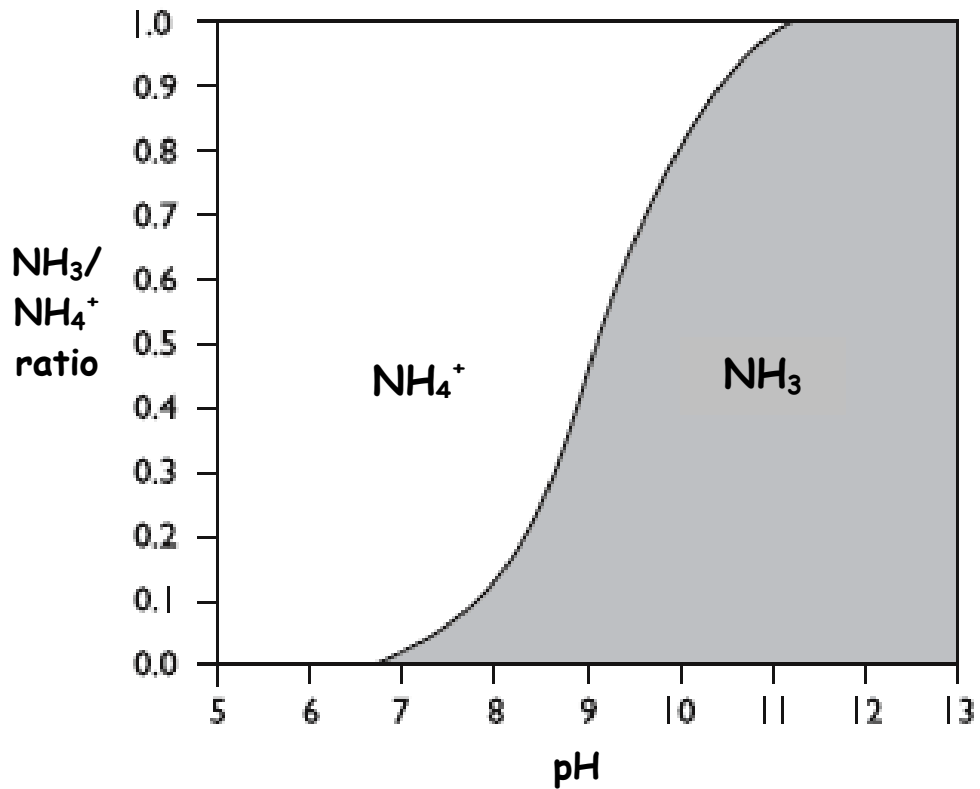

**Effect of
incorporation
on N
volatilization**

The best way to minimize N volatilization losses from applications of manure is incorporation. Table 9.10 shows the volatilization factors that can be used to predict losses of ammonia under three different application scenarios. This factor should be multiplied by the manure ammonium/ammonia content to predict plant-available N.

Table 9.10. Manure ammonium-N availability factors for Virginia. (Virginia Department of Conservation and Recreation, 2005.)

Application method	Semi-solid manure	Liquid slurry	Lagoon liquid	Dry litter
	----- N availability factor -----			
Injection	-----	0.95	0.95	-----
Broadcast with immediate incorporation	0.75	0.75	0.90	0.90
Incorporated after 2 days	0.65	0.65	0.80	0.80
Incorporated after 4 days	0.40	0.40	0.60	0.65
Incorporated after 7 days or never incorporated	0.25	0.25	0.45	0.50
Irrigation without incorporation	-----	0.20	0.50	-----

Calculating plant-available N (PAN)

The amount of nitrogen available to crops during the first year following application of manure is referred to as *plant-available nitrogen*, or *PAN*. PAN is the total of the inorganic nitrogen (primarily ammonium, or $\text{NH}_4^+\text{-N}$) and the percentage of the organic nitrogen that will mineralize during the growing season.

The first step in calculating PAN is to **determine the amount of organic and inorganic N in your manure**. Most manure analyses do not provide this information directly. Instead, they give the total amount of N (usually as total Kjeldahl N, or TKN) and the inorganic N ($\text{NH}_4^+\text{-N}$) present (as pounds of nutrient per ton or per 1,000 gallons) in the sample. To determine the organic fraction, simply subtract the $\text{NH}_4^+\text{-N}$ value from the TKN value, as follows:

Step 1: $\text{TKN} - \text{NH}_4^+\text{-N} = \text{Organic N}$

The second step is to **estimate the amount of organic nitrogen that will mineralize during the first year**. This is calculated by multiplying your value for organic N by a mineralization factor. Table 9.9 can be used to obtain a mineralization factor that matches a particular manure type.

Step 2: $\text{Organic N} * \text{Mineralization Factor} = \text{Organic N Available First Year}$
 (from Step 1) (from Table 9.9) (lbs/ton or lbs/1000 gallons)

The third step is to **estimate the amount of $\text{NH}_4^+\text{-N}$ that will be available**

following land application. This can be estimated using the volatilization factors from Table 9.10.

Step 3: $\text{NH}_4^+\text{-N}$ (from lab analysis) * volatilization factor = available $\text{NH}_4^+\text{-N}$ (lbs/ton or lbs/1000 gallons).

Then, to **calculate PAN**, simply add the organic N available the first year (from Step 2) to the available ammonium-nitrogen ($\text{NH}_4^+\text{-N}$) available (from Step 3).

Step 4: Available $\text{NH}_4^+\text{-N}$ + Organic Available First Year = PAN (lbs/ton or lbs/1,000 gallons)

Equipment calibration

The information in the preceding sections will be useless if the manure is not applied uniformly and at a known rate. Proper calibration of manure application equipment is a critical part of manure and nutrient management.

Regardless of the design of the equipment or type of manure, manure application equipment can be calibrated in one of three basic ways (Koelsch, 1995):

- The *tarp* method:
Place a tarp flat on the field, spread manure on the tarp, weigh the manure, and calculate the application rate.
- The *swath and distance* method:
Determine the swath width and distance traveled to empty the spreader and calculate the rate based on area covered and the weight of the load.
- The *loads-per-field* method:
Simply count the number of loads of manure applied and divide by the numbers of acres.

For each of the calibration methods, it is critical that all of the controllable variables (i.e., equipment speed, gate settings, type and consistency of manure) remain constant!

Calibrating with the tarp method

The tarp method consists of placing a tarp (or plastic sheet) on the ground and using the manure spreader to spread the manure on the tarp. The collected manure is weighed, and the application rate is determined from the weight of the manure collected and the area of the plastic sheet or tarp used. This measurement should be repeated at least three times and the results averaged to ensure a consistent application rate.

Table 9.11 provides conversion factors to easily calculate the application rate based on the quantity of manure collected and some common tarp sizes.

Alternately, the rate can be calculated by simply dividing the number of pounds of manure collected by the area (in square feet) of the tarp. The result will be the pounds of manure per square foot. This number can be multiplied by 21.78 to give the tons per acre.

Example: You have an 8 ft by 8 ft tarp and you collect 8.8 lbs of manure on the tarp. The calculation would be:

$$8.8 \text{ lbs} / 64 \text{ sq ft } (8 \text{ ft} * 8 \text{ ft} = 64 \text{ sq ft}) = 0.1375 \text{ lbs/sq ft}$$

$$0.1375 \text{ lbs/sq ft} * 21.78 = 3 \text{ tons/acre applied}$$

Table 9.11. Application rate in tons per acre (T/A) for four common tarp sizes (Mancl, 1996).

Pounds (lbs) of waste collected	-----Tarp dimensions-----			
	6 ft by 6 ft	8 ft by 8 ft	10 ft by 10 ft	10 ft by 12 ft
	-----Application rate (T/A)-----			
1	0.61	0.34	0.22	0.18
3	1.82	1.02	0.65	0.54
4	2.42	1.36	0.87	0.73
5	3.03	1.70	1.09	0.91
10	6.05	3.40	2.18	1.82
15	9.08	5.10	3.27	2.72
20	12.10	6.81	4.36	3.63

**Calibrating
with the swath
and distance
method**

Calculations for determining application rate for the swath and distance method are similar to those used for the tarp method above. First, determine the weight of a “load” of manure either by direct measurement (i.e., weighing) or by converting from volume measurement. (Many applicators are rated by bushel or cubic foot capacity). Second, determine the width of the application swath and the distance required to apply the load. From this point, the calculations are identical to those used above.

Example: You have a spreader that holds 7000 lbs of manure (3.5 tons). Your application width is 35 ft and the equipment travels 1200 feet along a field to empty the load. The calculation would be:

$$7000 \text{ lbs} / 42,000 \text{ sq ft } (35 \text{ ft} * 1200 \text{ ft} = 42,000 \text{ sq ft}) = 0.1667 \text{ lbs/sq ft}$$

$$0.1667 \text{ lbs/sq ft} * 21.78 = 3.63 \text{ tons/acre applied}$$

**Calibrating
with the loads-
per-field
method**

The loads-per-field method is the easiest to calculate. The major drawback of this method is that it is an “after the fact” calculation so that the applicator does not have the opportunity to make adjustments in the application rate for the particular field. This method may best be used as a method of monitoring application rates during the clean-out of a storage facility, using the first two methods described to actually calibrate the spreader before the full scale application of manure begins.

First, determine the weight in tons of a load of manure. Second, determine the size of the field in acres. It is then a simple matter of counting the number of loads applied to the field, multiplying that number by the weight in tons of a single load, and then dividing that number by the acreage of the field.

Example: You have a spreader that holds 7000 lbs of manure (3.5 tons). Your field is 55 acres and you apply 35 loads to the field. The calculation would be:

$$\begin{aligned} 35 \text{ loads} * 3.5 \text{ tons/load} &= 122.5 \text{ tons} \\ 122.5 \text{ tons} / 55 \text{ acres} &= 2.23 \text{ tons/acre applied} \end{aligned}$$

References cited

- Angel, R., A. S. Dhandu, T. J. Applegate, and M. Christman. 2001. Phosphorus sparing effect of phytase, 25-hydroxycholecalciferol, and citric acid when fed to broiler chicks. *Poultry Sci.* 80 (Suppl. 1):133-134.
- Bandel, V.A. 1990. Using manure to cut fertilizer costs. University of Maryland Cooperative Extension Service Fact Sheet 512.
- Fulhage, C.D., and D.L. Pfof. 2002. Fertilizer nutrients in livestock and poultry manure. University of Missouri Cooperative Extension Bulletin EQ351.
- Gay, S.W., and K.F. Knowlton. 2005. Ammonia emissions and animal agriculture. Virginia Cooperative Extension Publication 442-110.
- Hansen, D.J., J. Nelson, G.D. Binford, J.T. Sims, and W. Saylor. 2005. Phosphorus in poultry litter: New guidelines for the University of Delaware. Delaware Cooperative Extension Fact Sheet NM-07.
- Hermanson, R.E. 1996. Manure sampling for nutrient analysis with worksheets for calculating fertilizer values. Washington State Cooperative Extension Bulletin EB1819.
- Koelsch, R.K. 1995. Manure spreader calibration. University of Nebraska Cooperative Extension NebGuide G95-1267-A.
- Maguire, R.O., J.T. Sims, and T.J. Applegate. 2005. Phytase supplementation and reduced phosphorus turkey diets reduce phosphorus loss in runoff following litter application. *J. Environ. Qual.* 34:359-369.
- Mancl, K. 1996. Land application of waste, spreading and injection. Ohio State University Extension Fact Sheet AEX-707-91.
- Nahm, K.H. 2002. Efficient feed nutrient utilization to reduce pollutants in poultry and swine manure. *Crit. Rev. Environ. Sci. Technol.* 32:1-16.
- National Research Council. 1994. Nutrient requirements of poultry. 9th ed. National Academy Press. Washington, D. C.
- Tetra Tech, Inc. 2004. Technical fundamentals of CAFOs for permit writers and inspectors - Student Text; Session 4. Tetra Tech, Pasadena, CA.
- VanDevender, K., J. Langston, and M. Daniels. 2004. Utilizing dry poultry

litter- an overview. University of Arkansas Extension Publication FSA8000-2.5M-12-OORV.

Virginia Department of Conservation and Recreation. 1993. Nutrient management handbook. 2nd edition. VA DCR, Richmond, VA.

Virginia Department of Conservation and Recreation. 2005. Virginia nutrient management standards and criteria. VA DCR, Richmond, VA.

Zublana, J.P., J.C. Barker, and T.A. Carter. 1990. Soil facts: Poultry manure as a fertilizer source. North Carolina Extension Service Pub. AG-439-5.

Chapter 10. Land Application of Biosolids

Gregory K. Evanylo

Department of Crop and Soil Environmental Sciences, Virginia Tech

Table of Contents

Introduction.....	228
What are biosolids and how are they different from sewage sludge?.....	228
Benefits of land application of biosolids	228
Production and characteristics of biosolids.....	229
How are biosolids produced?.....	229
Characterizing biosolids.....	231
Typical nutrient levels in biosolids.....	232
Federal regulations.....	233
Introduction.....	233
The Part 503 Rule	233
Pollutants and concentration limits.....	234
Pathogen reduction categories	236
Vector attraction reduction	236
N, P, and lime application rate.....	237
Site suitability	237
Managing biosolids for agricultural use	238
Selecting suitable crops for fertilization with biosolids.....	238
Determining biosolids application rates.....	238
Determining nutrient needs.....	239
Determining agronomic rates.....	239
Why is the application rate for biosolids usually based on crop N needs?.....	239
What is PAN, and how is it determined?.....	240
Determining availability of ammonium in biosolids	240
Determining availability of organic N in biosolids.....	241
Will agronomic N rates of biosolids meet all crop nutrient needs?.....	242
What problems can be caused by applying biosolids at agronomic N rates?	242
How are plant availabilities of P and K from biosolids determined?	243
Using soil pH and CCE as the basis for determining biosolids rate.....	243
Calculating nutrient-based biosolids application rates	244
Calculating annual agronomic N rate	244
Calculating annual agronomic P rate	245
Calculating agronomic lime requirement.....	245
Example: Determining N, P, and lime agronomic rates for a specific situation.....	245
Land application methods.....	247
Introduction.....	247
Applying liquid biosolids.....	247
Applying dewatered biosolids.....	248
Timing of biosolids application	248

Biosolids storage.....	248
Disadvantages of land application	248
References cited	251

Introduction

What are biosolids and how are they different from sewage sludge?

Biosolids are solid, semi-solid, or liquid materials resulting from treatment of domestic sewage that have been sufficiently processed to permit these materials to be land-applied safely. The term was introduced by the wastewater treatment industry in the early 1990's and has been recently adopted by the U.S. EPA to distinguish high quality, treated sewage sludge from raw sewage sludge and from sewage sludge containing large amounts of pollutants.

Benefits of land application of biosolids

Biosolids can be considered as a waste or as a beneficial soil amendment. As an alternative to disposal by landfilling or incineration, land application recycles soil-enhancing constituents such as plant nutrients and organic matter. The main fertilizer benefits are through the supply of nitrogen (N), phosphorus (P), and lime (where lime-stabilized biosolids are applied). Biosolids also ensure against unforeseen nutrient shortages by supplying essential plant nutrients [e.g., sulfur (S), manganese (Mn), zinc (Zn), copper (Cu), iron (Fe), molybdenum (Mo), and boron (B)] that are seldom purchased by farmers because crop responses to their application are unpredictable.

For links to web sites that provide detailed information on many aspects of land application of biosolids, see Sukkariyah et al., 2005, at http://www.agnr.umd.edu/users/waterqual/Publications/html_pubs/biosolids_wq_resource_directory.htm.

Production and characteristics of biosolids

How are biosolids produced?

Biosolids are produced primarily through biological treatment of domestic wastewater (Figure 10.1). Physical and chemical processes are often additionally employed to improve the biosolids handling characteristics, increase the economic viability of land application, and reduce the potential for public health, and environmental and nuisance problems associated with land application practices. These processes treat wastewater solids to control disease-causing organisms and reduce characteristics that might attract rodents, flies, mosquitoes, or other organisms capable of transporting infectious disease. The type and extent of processes used to treat wastewater will affect the degree of pathogen reduction attained and the potential for odor generation. Common treatment processes and their effects on biosolids properties and land application practices are summarized in Table 10.1.

Figure 10.1. Schematic diagram of wastewater treatment facility.

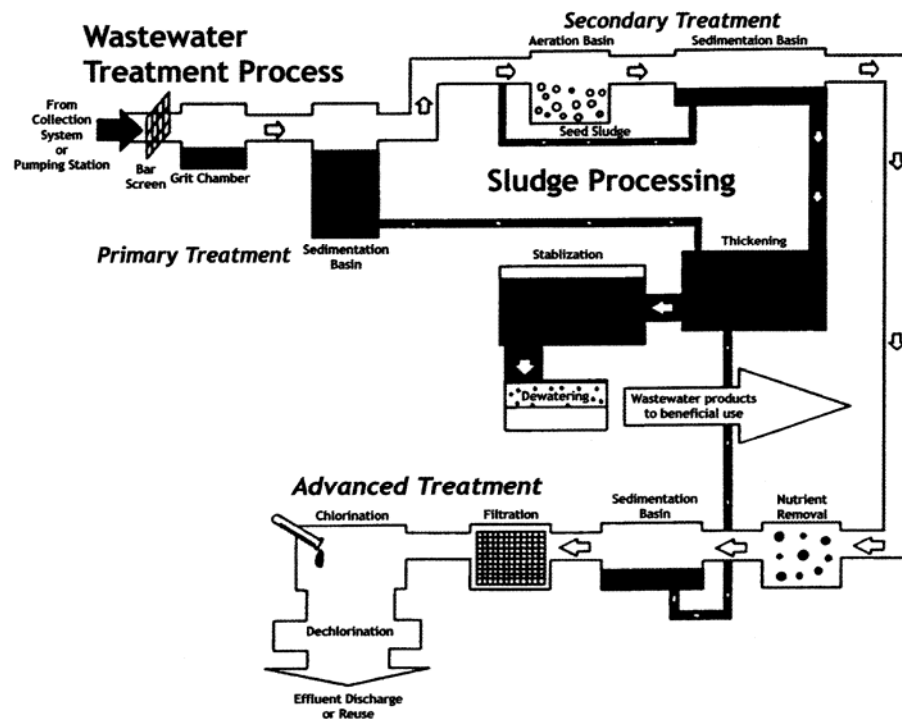

Table 10.1. Description of various wastewater and biosolids treatment processes and methods and their effects on land application practices (Adapted from U.S. EPA, 1984).

Process/Method	Process Definition	Effect on Biosolids	Effect on Land Application Process
<i>Wastewater treatment process</i>			
Thickening	Low force separation of water and solids by gravity, flotation, or centrifugation.	Increase solids content by removing water.	Lowers transportation costs.
<i>Stabilization methods</i>			
Digestion (anaerobic and/or aerobic)	Biological stabilization through conversion of organic matter to carbon dioxide, water, and methane.	Reduces biological oxygen demand, pathogen density, and attractiveness of the material to vectors (disease-spreading organisms).	Reduces the quantity of biosolids.
Alkaline stabilization	Stabilization through the addition of alkaline materials (e.g., lime, kiln dust).	Raises pH. Temporarily decreases biological activity. Reduces pathogen density and attractiveness of the material to vectors.	High pH immobilizes metals as long as pH levels are maintained.
Heat Drying	Drying of biosolids by increasing temperature of solids during wastewater treatment.	Destroys pathogens, eliminates most of water.	Greatly reduces sludge volume.
<i>Chemical and physical processes that enhance the handling of stabilized biosolids</i>			
Conditioning	Processes that cause biosolids to coagulate to aid in the separation of water.	Improves sludge dewatering characteristics. May increase dry solids mass and improve stabilization.	The ease of spreading may be reduced by treating biosolids with polymers.
Dewatering	High force separation of water and solids. Methods include vacuum filters, centrifuges, filter and belt presses, etc.	Increase solids concentration to 15% to 45%. Lowers N and potassium (K) concentrations. Improves ease of handling.	Reduces land requirements and lowers transportation costs.
<i>Advanced stabilization method</i>			
Composting	Aerobic, thermophilic, biological stabilization in a windrow, aerated static pile, or vessel.	Lowers biological activity, destroys most pathogens, and degrades sludge to humus-like material.	Excellent soil conditioning properties. Contains less plant available N than other biosolids.

Characterizing biosolids

The suitability of a particular biosolid for land application can be determined by biological, chemical, and physical analyses. Biosolids' composition depends on wastewater constituents and treatment processes. The resulting properties will determine application method and rate and the degree of regulatory control required. Several of the more important properties of biosolids are:

- *Total solids* include suspended and dissolved solids and are usually expressed as the concentration present in biosolids. The content of total solids depends on the type of wastewater process and biosolids' treatment prior to land application. Typical solids contents of various biosolids' processes are: liquid (2-12%), dewatered (12-30%), and dried or composted (50%).
- *Volatile solids* provide an estimate of the readily decomposable organic matter in biosolids and are usually expressed as a percentage of total solids. Volatile solids content is an important determinant of potential odor problems at land application sites. A number of treatment processes, including anaerobic digestion, aerobic digestion, alkaline stabilization, and composting, can be used to reduce volatile solids content and thus, the potential for odor.
- *pH* and *Calcium Carbonate Equivalent (CCE)* are measures of the degree of acidity or alkalinity of a substance. The pH of biosolids is often raised with alkaline materials to reduce pathogen content and attraction of disease-spreading organisms (vectors). High pH (greater than 11) kills virtually all pathogens and reduces the solubility, biological availability, and mobility of most metals. Lime also increases the gaseous loss (volatilization) of the ammonia (NH₃) form of N, thus reducing the N-fertilizer value of biosolids. CCE is the relative liming efficiency of the biosolids expressed as a percentage of calcium carbonate (calcitic limestone) liming capability.
- *Nutrients* are elements required for plant growth that provide biosolids with most of their economic value. These include N, P, K, calcium (Ca), magnesium (Mg), sodium (Na), S, B, Cu, Fe, Mn, Mo, and Zn. Concentrations in biosolids can vary significantly (Table 10.2), so the actual material being considered for land application should be analyzed.
- *Trace elements* are found in low concentrations in biosolids. The trace elements of interest in biosolids are those commonly referred to as "heavy metals." Some of these trace elements (e.g., Cu, Mo, and Zn) are nutrients needed for plant growth in low concentrations, but all of these elements can be toxic to humans, animals, or plants at high concentrations. Possible hazards associated with an accumulation of trace elements in the soil include their potential to cause phytotoxicity (i.e., injury to plants) or to increase the concentration of potentially hazardous substances in the food

chain. Federal and state regulations have established standards for the following nine trace elements: **arsenic (As), cadmium (Cd), copper (Cu), lead (Pb), mercury (Hg), molybdenum (Mo), nickel (Ni), selenium (Se), and zinc (Zn).**

- *Organic chemicals* are complex compounds that include man-made chemicals from industrial wastes, household products, and pesticides. Many of these compounds are toxic or carcinogenic to organisms exposed to critical concentrations over certain periods of time, but most are found at such low concentrations in biosolids that the U.S. EPA concluded they do not pose significant human health or environmental threats. Although no organic pollutants are included in the current federal biosolids regulations, further assessment of several specific organic compounds is being conducted as has been recommended by the National Research Council (2002).
- *Pathogens* are disease-causing microorganisms that include bacteria, viruses, protozoa, and parasitic worms. Pathogens can present a public health hazard if they are transferred to food crops grown on land to which biosolids are applied; contained in runoff to surface waters from land application sites; or transported away from the site by vectors such as insects, rodents, and birds. For this reason, federal and state regulations specify pathogen and vector attraction reduction requirements that must be met by biosolids applied to land.

**Typical
nutrient levels
in biosolids**

There have been very few comprehensive surveys of nutrient levels in biosolids during the past 25 years. One such recent study conducted by Stehouwer et al. (2000) demonstrated that the macronutrient (N, P, and K) concentration of biosolids has changed very little from the late 1970's to the mid 1990's. The data in Table 10.2 represent the means and variability of more than 240 samples collected and analyzed from 12 publicly owned treatment works (POTWs) in Pennsylvania between 1993 and 1997. The POTWs each provided a minimum of 20 analytical records between 1993 and 1997. The 12 POTWs generated between 110 and 60,500 tons of biosolids per year and employed either aerobic digestion (3 facilities), anaerobic digestion (4 facilities), or alkaline addition (5 facilities).

Table 10.2. Means and variability of nutrient concentrations^a in biosolids collected and analyzed in Pennsylvania between 1993 and 1997 (Stehouwer et al., 2000).

Nutrient	Total N ^b	NH ₄ -N	Organic N	Total P	Total K
	-----%-----				
Mean	4.74	0.57	4.13	2.27	0.31
Variability^c	1.08	0.30	1.03	0.89	0.27

^a Concentrations are on a dried solids basis.

^b Determined as total Kjeldahl nitrogen.

^c Standard deviation of the mean.

Federal regulations

Introduction

Land application of biosolids involves some risks, which are addressed through federal and state regulatory programs. Pollutants and pathogens are added to soil with organic matter and nutrients. Human and animal health, soil quality, plant growth, and water quality could be adversely affected if land application is not conducted in an agronomically and environmentally sound manner. In addition, N and P in biosolids, as in any fertilizer source, can contaminate groundwater and surface water if the material is overapplied or improperly applied. There are risks and benefits to each method of biosolids disposal and use.

The Part 503 Rule

As required by the Clean Water Act Amendments of 1987, the U.S. EPA developed the regulation, The Standards for the Use or Disposal of Sewage Sludge (Title 40 of the Code of Federal Regulations [CFR], Part 503). This is commonly known as the *Part 503 Rule*. The Part 503 Rule establishes minimum requirements when biosolids are applied to land to condition the soil or fertilize crops or other vegetation grown in the soil. The Clean Water Act required that this regulation protect public health and the environment from any reasonably anticipated adverse effects of pollutants and pathogens in biosolids.

Federal regulations require that state regulations be at least as stringent as the Part 503 Rule. The underlying premise of both the federal and state regulations is that biosolids should be used in a manner that limits risks to human health and the environment. The regulations prohibit land application of low-quality sewage sludge and encourage the application of biosolids that are of sufficient quality that they will not adversely affect human health or the environment. Determination of biosolids quality is based on trace element (pollutant) concentrations and pathogen and vector attraction reduction.

Pollutants and concentration limits

The Part 503 Rule prohibits land application of sewage sludge whose pollutant concentrations exceed certain limits (Table 10.3) for nine trace elements: As, Cd, Cu, Pb, Hg, Mo, Ni, Se, and Zn. Such materials should not be applied to land and are not considered biosolids.

- *Ceiling concentration limits (CCL)* are the maximum concentrations of the nine trace elements allowed in biosolids to be land applied. Sewage sludge exceeding the ceiling concentration limit for even one of the regulated pollutants is not classified as biosolids and, hence, cannot be land applied.
- *Pollutant concentration limits (PCL)* are the most stringent pollutant limits included in Part 503 for land application. Biosolids meeting pollutant concentration limits are subject to fewer requirements than biosolids meeting ceiling concentration limits. Results of the U.S. EPA's 1990 National Sewage Sludge Survey (NSSS) (U.S. EPA, 1990) demonstrated that the mean concentrations of the nine regulated pollutants are considerably lower than the most stringent Part 503 pollutant limits.
- The *cumulative pollutant loading rate (CPLR)* is the total amount of a pollutant that can be applied to a site in its lifetime by all bulk biosolids applications meeting ceiling concentration limits. No additional biosolids meeting ceiling concentration limits can be applied to a site after the maximum cumulative pollutant loading rate is reached at that site for any one of the nine regulated trace elements. Only biosolids that meet the more stringent pollutant concentration limits may be applied to a site once a cumulative pollutant loading rate is reached at that site.

In 1987, the U.S. EPA established pretreatment specifications (40 CFR Part 403) that require industries to limit the concentrations of certain pollutants, including trace elements and organic chemicals, in wastewater discharged to a treatment facility. An improvement in the quality of biosolids over the years has largely been due to pretreatment and pollution prevention programs (Shimp et al., 1994).

Part 503 does not regulate organic chemicals in biosolids because the chemicals of potential concern have been banned or restricted for use in the United States; are no longer manufactured in the United States; are present at low concentrations based on data from the U.S. EPA's 1990 NSSS (U.S. EPA, 1990); or because the limit for an organic pollutant identified in the Part 503 risk assessment is not expected to be exceeded in biosolids that are land applied (U.S. EPA, 1992a). The National Research Council concluded, in their review of the science upon which the Part 503 Rule was based, that additional testing of certain organic compounds should be conducted (National Research Council, 2002). These included poly-brominated diphenyl ethers, nonyl phenols, pharmaceuticals, and other potential carcinogenic and

endocrine-pathway disrupting personal care products. Restrictions will be imposed for agricultural use if testing of these organic compounds verifies that biosolids contain levels that could cause harm.

Individual states may impose additional regulations that are at least as stringent as the federal regulations. Links to websites with more information on Mid-Atlantic state regulations can be found on-line at:

http://www.agnr.umd.edu/users/waterqual/Publications/html_pubs/biosolids_wq_resource_directory.htm (Sukkariyah et al., 2005).

Table 10.3. Regulatory limits (adapted from U.S. EPA, 1995) and mean concentrations measured in biosolids from the National Sewage Sludge Survey (U.S. EPA, 1990) and a survey of 12 Pennsylvania POTWs between 1993 and 1997 (Stehouwer et al., 2000).

Pollutant	CCL^{a,b}	PCL^{a,c}	CPLR^{a,d}	Mean^{a,g}	Mean^{a,h}
	-ppm ^f -	-ppm-	--lbs/A--	--ppm--	--ppm--
Arsenic (As)	75	41	36	10	5
Cadmium	85	39	35	7	3
Copper	4300	1500	1340	741	476
Lead	840	300	270	134	82
Mercury	57	17	16	5	2
Molybdenum	75	^e	^e	9	13
Nickel	420	420	375	43	23
Selenium	100	100	89	5	4
Zinc	7500	2800	2500	1202	693

^a Dry weight basis.

^b CCL (ceiling concentration limits) = maximum concentration permitted for land application.

^c PCL (pollutant concentration limits) = maximum concentration for biosolids whose trace element pollutant additions do not require tracking (i.e., calculation of CPLR).

^d CPLR (cumulative pollutant loading rate) = total amount of pollutant that can be applied to a site in its lifetime by all bulk biosolids applications meeting CCL.

^e The February 25, 1994 Part 503 Rule amendment deleted the molybdenum PCL for sewage sludge applied to agricultural land but retained the molybdenum CCL.

^f ppm = part per million.

^g Data from U.S. EPA, 1990.

^h Data from Stehouwer et al., 2000.

**Pathogen
reduction
categories**

Federal and state regulations require the reduction of potential pathogens and vector attraction properties. Biosolids intended for land application are normally treated by chemical or biological processes that greatly reduce the number of pathogens and odor potential in sewage sludge. Two levels of pathogen reduction, Class A and Class B, are specified in the regulations:

- The goal of *Class A* requirements is to reduce the pathogens (including *Salmonella* sp., bacteria, enteric viruses, and viable helminth ova) to **below detectable levels**. Class A biosolids can be land applied without any pathogen-related site restrictions. Processes to further reduce pathogens (PFRP) treatment, such as those involving high temperature, high pH with alkaline addition, drying, and composting, or their equivalent are most commonly used to demonstrate that biosolids meet Class A requirements. Biosolids that meet the Part 503 PCLs, Class A pathogen reduction, and a vector attraction reduction option that reduces organic matter are classified as exceptional quality or EQ biosolids.
- The goal of *Class B* requirements is to ensure that pathogens have been reduced to **levels that are unlikely to cause a threat to public health and the environment under specified use conditions**. Processes to significantly reduce pathogens (PSRP), such as digestion, drying, heating, and high pH, or their equivalent are most commonly used to demonstrate that biosolids meet Class B requirements. Because Class B biosolids contain some pathogens, certain site restrictions are required. These are imposed to minimize the potential for human and animal contact with the biosolids until environmental factors (temperature, moisture, light, microbial competition) reduce the pathogens to below detectable levels. The site restriction requirements in combination with Class B treatment is expected to provide a level of protection equivalent to Class A treatment. All biosolids that are land applied must, as a minimum, meet Class B pathogen reduction standards.

**Vector
attraction
reduction**

The objective of vector attraction reduction is to prevent disease vectors such as rodents, birds, and insects from transporting pathogens away from the land application site. There are ten options available to demonstrate that land-applied biosolids meet vector attraction reduction requirements. These options fall into either of the following two general approaches: 1) reducing the attractiveness of the biosolids to vectors with specified organic matter decomposition processes (e.g., digestion, alkaline addition) and 2) preventing vectors from coming into contact with the biosolids (e.g., biosolids injection or incorporation below the soil surface within specified time periods).

N, P, and lime application rate Federal regulations specify that biosolids may only be applied to agricultural land at or less than the rate required to supply the N need of the crops to be grown. This *agronomic rate* is “*designed to provide the amount of N needed by the food crop, feed crop, fiber crop, or vegetation grown on the land; and (2) to minimize the amount of N in the biosolids that passes below the root zone of the crop or vegetation grown on the land to the groundwater*” [40 CFR 503.11 (b)]. Agronomic rate may also be based on crop P needs if it is determined that excessive soil P poses a threat to water quality.

Although not technically a nutrient, lime may also be used as a basis for agronomic biosolids application rate. Biosolids rate may be limited by the CCE when the application of alkaline-stabilized biosolids on an N or P basis may raise soil pH to a level that can induce a trace element deficiency. By signing the land application agreement with a biosolids contractor, the farmer is obligated to make every reasonable attempt to produce a crop on sites receiving biosolids that matches the agronomic rate applied.

Site suitability Federal, state, and local regulations, ordinances or guidelines place limits on land application based on site physical characteristics that influence land application management practices. These include topography; soil permeability, infiltration, and drainage patterns; depth to groundwater; and proximity to surface water.

Potentially unsuitable areas for biosolids application include:

- areas bordered by ponds, lakes, rivers, and streams without appropriate buffer zones
- wetlands and marshes
- steep areas with sharp relief
- undesirable geology (karst, fractured bedrock) if not covered by a sufficiently thick layer of soil
- undesirable soil conditions (rocky, shallow)
- areas of historical or archeological significance
- other environmentally sensitive areas, such as floodplains

Managing biosolids for agricultural use

Selecting suitable crops for fertilization with biosolids

Crops such as corn, soybean, small grains, and forages have high N assimilative capacities. When these crops are grown on land used for biosolids recycling, the amount of land required when biosolids are applied on an N basis can be reduced. Crops grown for their flowering parts, such as cotton, may produce undesirable amounts of vegetative growth if they continue to accumulate N late in the season, so slow release N sources such as biosolids may not be desirable fertilizer sources for such crops. Biosolids can, however, be used without concern on other crops in rotation with cotton. The tobacco industry, however, has expressly forbidden the use of biosolids for fertilizing tobacco because the crop readily accumulates heavy metals such as Cd.

Biosolids can be applied to vegetable crops, but green leafy vegetables accumulate higher concentrations of metals than do the grain of agronomic crops. Some scientists have cautioned against using biosolids on vegetable crops because they provide a direct pathway of potentially harmful trace elements from the soil to humans, while others (Chaney, 1994) have demonstrated that certain soil and plant barriers exist that prevent trace elements in biosolids of current quality from posing such risks. Regardless of one's interpretation of the trace element bioavailability evidence, grain and forage crops are better choices for biosolids application than vegetables due to other issues (for example, the time required by regulation between Class B biosolids application and permitted harvesting of crops that can be consumed by humans).

Determining biosolids application rates

Biosolids supply some of all of the essential plant nutrients and soil property-enhancing organic matter. Land application rates, however, are primarily based on the abilities of biosolids to supply N, P, and (in the case of alkaline stabilized materials) lime.

The general approach for determining biosolids application rates on agricultural land is summarized in the following steps:

1. Determine **nutrient needs** for crop yield expected for the soil on which the crop will be grown, and soil test nutrient and pH levels to account for residual nutrient availability.
2. Calculate **biosolids agronomic rates** based on either:
 - crop N needs (normally), or
 - soil test P levels (if excess P is a problem), or
 - soil lime requirement (when lime-supplying biosolids are used and will

raise soil pH above the desirable range if they are applied on an N basis).

3. Calculate **supplemental fertilizer needs** by subtracting the amount of plant-available N, P, and K supplied by biosolids from the crop's N, P, and K needs.

Determining nutrient needs

Fertilizer recommendations are based on the nutrient-supplying capability of the soil and the additional nutrients needed by crops to achieve their potential yield. Soil testing is required prior to the application of biosolids to determine the suitability of soil pH and the availability of P and K. Soil testing can disclose whether limestone, P or K is required for optimum crop productivity. Nitrogen application rates are based on crop N needs for expected yields for a specific soil.

Determining agronomic rates

Biosolids are normally applied at rates to provide the N needed or that which can be assimilated by the crop. This is known as the *agronomic N rate*. Fertilizer N is not normally applied to legumes, which can obtain N from the atmosphere; however, nitrogen assimilative capacity is used to establish agronomic N rates for legumes because they will use biosolids-furnished soil nitrogen. The relative concentrations of nutrients in biosolids are rarely present in the proportions required by the target crop; thus, supplemental fertilization (for example, with K) may be needed to promote optimum vegetative growth and yield.

Biosolids should be applied at rates that supply no more than the agronomic N rate for the specific crop and soil type. One of the systems developed and used in the Mid-Atlantic region to estimate expected yield potential and associated nutrient needs/assimilative capacity is the Virginia Agronomic Land Use Evaluation System (VALUES; Simpson et al., 1993). VALUES and other systems nutrient recommendation systems employed by soil testing laboratories base their fertilizer recommendations on empirical variations in yield potentials of soils for different crops.

Why is the application rate for biosolids usually based on crop N needs?

Nitrogen is required by crops in greater amounts than any other nutrient; thus, the crop's requirement for most other nutrients is normally met when the agronomic N rate is applied. Biosolids rate is further limited to N supplying capacity because N (as nitrate) is the nutrient most likely to be lost to surface and groundwater if applied at greater than agronomic rates.

The following cautions regarding the determination of agronomic N rates should be considered:

- The amount of plant-available N can be underestimated or overestimated

because the N composition of biosolids that is used to establish the average N concentration can vary significantly during the period of time that samples are collected and analyzed to establish the agronomic N rate.

- The equations used to calculate plant-available N are not site or source specific, and the actual amounts of plant-available N may vary from the target rates.

These problems occur with other types of organic wastes, such as manures and yard waste composts, and are not unique to biosolids.

What is PAN, and how is it determined?

Only a portion of the total N present in biosolids is available for plant uptake. This *plant available nitrogen* or *PAN* is the actual amount of N in the biosolids that is available to crops during a specified period. Equations for calculating PAN are relatively straightforward, but selecting precise site and source specific availability coefficients and reasonable input values is more challenging. Site-specific data, when available, should always be used in preference to “book” values.

Determining availability of ammonium in biosolids

Nitrogen in biosolids may occur in the ammonium (NH_4^+) or nitrate (NO_3^-) forms that are found in commercial inorganic fertilizers, or in organically-bound forms that are found in materials such as manures and composts. The amount of N that will be available to plants varies for each N form. Nitrate is readily plant-available but is not found in high concentrations in most biosolids. Ammonium is also available to plants, but it can be lost to the atmosphere (via volatilization) as ammonia (NH_3) gas when biosolids are applied to land without prompt incorporation into the soil. The available (non-volatilizable) fraction of NH_4^+ -N may be estimated based on the time of incorporation after application. Examples of N availability coefficients from the non-volatized fraction of NH_3 used in Virginia are presented in Table 10.4.

Table 10.4. Examples of estimated plant available percentage of ammonia from biosolids (adapted from Virginia Biosolids Use Regulations - Table 12; Virginia Department of Health, 1997).

Management Practice	Biosolids with pH lower than 10	Biosolids with pH higher than 10
	----- available % NH ₃ -----	
Injection below surface	100	100
Surface application with:		
• incorporation within 24 hours	85	75
• incorporation within 1-7 days	70	50
• incorporation after 7 days	50	25

Determining availability of organic N in biosolids

Organic N must be broken down to NH₄⁺ (via mineralization) and NO₃⁻ (via nitrification) by soil microorganisms before this form of nitrogen is available for plants to use. Organic N can thus be considered to be a slow release form of nitrogen. The amount of PAN from organic N is estimated by using factors established by research (e.g., Gilmour et al., 2003), such as those presented in Table 10.5. The largest portion of organic N in biosolids is converted to plant available N during the first year after application to the soil.

For example, if the values in Table 10.5 are applied to Virginia, the percentages of organic N that will become available for non-irrigated corn uptake (E_{min}) upon mineralization of land-applied biosolids that have been treated via aerobic or anaerobic digestion, alkaline addition or heating are:

- 30% during the first year after application
- 10% of the remaining organic N during each of the second and third years
- 5% of the remaining organic N during the fourth year

The values in Tables 10.4 and 10.5 may not be the most appropriate for all biosolids applied to any soil, but such “book” values are normally used when site specific data are not available. The amounts of available ammonium (NH₄⁺) plus the available portion of the organic N are used to calculate the rate of biosolids needed to supply a given amount of plant available N. Equations for calculating PAN are relatively straightforward, but selecting precise site and source specific availability coefficients is an imprecise exercise. Site-specific data should be used if it is available.

Table 10.5. Biosolids organic N mineralization factors recommended by Gilmour et al. (2000, 2003) for annual (K_{min}) and growing season (E_{min}) periods in the Mid-Atlantic states under dryland and irrigated conditions. E_{min} is the effective mineralization factor for the growing season portion of the year. N use efficiency for this period was determined to be 71%.

	----- Non-irrigated -----				----- Irrigated -----			
State	Year 1	Year 2	Year 3	Year 4	Year 1	Year 2	Year 3	Year 4
	----- K_{min} -----							
PA	0.42	0.14	0.14	0.07	0.42	0.21	0.14	0.07
DE	0.42	0.14	0.14	0.07	0.42	0.21	0.14	0.07
MD	0.42	0.14	0.14	0.07	0.42	0.21	0.14	0.07
WV	0.42	0.14	0.14	0.07	0.42	0.21	0.14	0.07
VA	0.42	0.14	0.14	0.07	0.50	0.21	0.14	0.07
	----- E_{min} -----							
PA	0.30	0.10	0.10	0.05	0.30	0.15	0.10	0.05
DE	0.30	0.10	0.10	0.05	0.30	0.15	0.10	0.05
MD	0.30	0.10	0.10	0.05	0.30	0.15	0.10	0.05
WV	0.30	0.10	0.10	0.05	0.30	0.15	0.10	0.05
VA	0.30	0.10	0.10	0.05	0.35	0.15	0.10	0.05

Will agronomic N rates of biosolids meet all crop nutrient needs?

Agronomic N rates of biosolids do not necessarily meet all crop nutrient requirements. For example, potassium (K) is often recommended for agronomic crops grown in Virginia soils, but the nutrient is present in low concentrations in biosolids. Supplemental K fertilization based on soil testing may be required for optimum plant growth where biosolids are applied.

What problems can be caused by applying biosolids at agronomic N rates?

Biosolids normally supply similar amounts of plant available N and P, but crops require one-fifth to one-half as much P as N. If P in a certain biosolid is largely contained in forms that are readily soluble/plant-available, then applying the biosolids at rates to supply the N needs of crops will eventually supply more P than necessary. Many soils in the Chesapeake Bay region contain very high concentrations of P due to long-term manure application or repeated fertilization with commercial P fertilizer. Long-term application of N-based biosolids rates can increase the potential for P contamination of surface water where soil P concentrations are already high. To alleviate the potential of P runoff or leaching in such cases, it may be advisable to apply the biosolids at rates to meet the P needs of the crop. The need to apply biosolids on a P basis can be verified with the use of a site-specific assessment tool, such as the P Index, which incorporates P transport risk in addition to soil P quantity factors. Applying biosolids on a P basis would likely require a farmer to purchase fertilizer N to meet the crop needs.

How are plant availabilities of P and K from biosolids determined?

The U.S. EPA (1995) estimated that 50% of the total P and 100% of the total K applied in biosolids would be available for plant uptake in the year of application. A Mid-Atlantic regional water quality workgroup has established that the availability of P in biosolids varies widely (i.e., <20% to >80%) according to the composition of P-binding constituents (esp., Al, Fe, and Ca) and the treatment processes to which the wastewater solids are subjected (http://www.agnr.umd.edu/users/waterqual/Publications/pdfs/PSI_white_paper_03_29_05.pdf). Such variability in biosolids P solubility is employed in specialized P application rate recommendations tools, such as the P Site Index (see Chapter 7).

The quantities of available P and K applied to soil with the biosolids may be credited against fertilizer recommendations in the year of application. Any P and K in excess of plant needs will contribute to soil fertility levels that can regularly be monitored via soil testing and taken into account when determining fertilizer recommendations in succeeding years.

Using soil pH and CCE as the basis for determining biosolids rate

Soil pH influences the availability and toxicity of naturally occurring metals and metals applied to soil in biosolids. Most crops grow well in Virginia soils at pH levels between 5.8 and 6.5. Based on previous U.S. EPA guidance, some states require that soils treated with biosolids be maintained at a pH of 6.5 or higher to reduce metal uptake by crops. Federal regulations do not require a minimum soil pH because pH was factored into the Part 503 risk assessment on which the regulation was based (U.S. EPA, 1992b). It is advisable to maintain the pH of agricultural soils where biosolids have been applied in the optimum range for crop growth (i.e., 5.8 to 6.5) to avoid phytotoxicity.

The CCE of the alkaline-stabilized biosolids may be used to determine application rates. The pH of coarse-textured (i.e., sandy) soils can rise rapidly when limed. Deficiencies of manganese in wheat and soybean and zinc in corn have sometimes been caused by excessive liming (pH > 6.8) of coarse-textured, Coastal Plain soils. Application of lime-stabilized biosolids at agronomic N rates to such soils that already have high pH values can induce such deficiencies. Crop yield reductions may result if the deficiency is not corrected, and the N not utilized by the crop can potentially leach into groundwater; thus, alkaline-stabilized biosolids should not be applied at rates that raise the soil pH in Coastal Plain soils above 6.5 and in all other soils above 6.8.

Magnesium deficiencies have been reported in row crops where repeated applications of calcitic (high Ca, low Mg) limestone has reduced soil Mg concentrations. Such soils can be identified by soil testing and should not receive further additions of “calcium only” liming materials, including Ca-based, lime-stabilized biosolids.

Calculating nutrient-based biosolids application rates

Calculating
annual
agronomic N
rate

Annual agronomic N rate calculations	
Step	Action
1	Determine N recommendation for the crop based on the expected yield level for the soil. Use state or private soil testing laboratory fertilizer nutrient recommendations or similar tool (e.g., VALUES).
2	Subtract anticipated N credits (i.e., other sources of N) from the recommended N rate, such as: <ul style="list-style-type: none"> • Residual N from a previous legume crop. • N that has already been applied or will be applied for the crop by fertilizer, manure, or other sources that will be readily available to plants. • Residual N remaining from application of previous by-product (e.g., manure, biosolids).
3	Calculate the adjusted biosolids N rate by subtracting N available from existing and planned sources from total N requirement of crop.
4	Calculate the PAN/dry ton of biosolids for the first year of application using Equation 1 : $\text{PAN} = \text{NO}_3\text{-N} + K_{\text{vol}} (\text{NH}_4^+\text{-N}) + K_{\text{min}} (\text{Org-N})$ where: PAN = lbs plant-available N/dry ton biosolids. NO₃-N = lbs nitrate N/dry ton biosolids. K_{vol} = volatilization factor, or plant-available fraction of NH ₄ -N (Table 10.4). NH₄-N = lbs ammonium N/dry ton biosolids. K_{min} = mineralization factor, or plant-available fraction of Org-N (Table 10.5). Org-N = lbs organic N/dry ton biosolids (estimated by subtraction NH ₄ -N from total Kjeldahl N).
5	Calculate the amount of biosolids required to supply the crop N needs using this equation: $\text{Dry tons biosolids required/acre} = \text{adjusted biosolids N rate (in lbs/acre)} \div \text{PAN/dry ton biosolids.}$ Then divide the tons of dry biosolids by the % solids to convert to wet weight of biosolids required.

Calculating annual agronomic P rate

Applying biosolids to meet the P, rather than the N, needs of the crop is a conservative approach for determining annual biosolid application rates. A scientifically sound approach, which accounts for both P availability and P transport, is the use of a tool such as the P Index (see Chapter 7; and). Supplemental N fertilization will be needed to optimize crop yields (except for N-fixing legumes) if biosolids application rates are based on a crop's P needs.

Calculating agronomic lime requirement

Application rates for lime-stabilized or lime-conditioned biosolids may be computed by determining the biosolids' CCE. The CCE provides a direct comparison of the liming value of the biosolids with calcium carbonate limestone, which is the basis for soil testing liming requirements. Biosolids conditioned or stabilized with lime may have a CCE between 10 and 50% on a dry weight basis. The agronomic lime rate for a biosolid can be determined by using **Equation 2**:

$$\text{Dry tons biosolids per acre} = \frac{\text{tons of CCE required/acre}}{\text{biosolids CCE}/100}$$

Example: Determining N, P, and lime agronomic rates for a specific situation

A lime-stabilized biosolid has a pH>10, a CCE of 40%, a NO₃-N concentration of 1,000 ppm (0.1%), an NH₄-N concentration of 2,000 ppm (0.2%), a TKN concentration of 27,000 ppm (2.7%), and a total P concentration of 21,000 ppm (2.1%), all on a dry weight basis (% dry solids is 17.6%). Corn for grain is to be grown on a Kempsville sandy loam soil that has a pH of 6.2, "high" K, Ca, and Mg soil test ratings, and a "very high" P soil test rating. The biosolids will be surface-applied and disked into the soil within 24 hours. How can the agronomic rate of the biosolid be determined?

Determining N, P, and lime-based agronomic rates	
Step	Action
1	<p>Determine N recommendation for the crop based on the expected yield level for the soil.</p> <p>The estimated yield potential of corn grown on a Kempsville soil according to one method (VALUES) is 120 bu/acre (Simpson et al., 1993), which should require about 132 lbs N/acre (assumption: 1.1 lbs N per bu of corn).</p>

2	<p>Calculate the N-based agronomic rate (using Equation 1) by:</p> <p>a) Calculating the components of PAN in the biosolid: $\text{NO}_3\text{-N} = 1,000 \text{ ppm} \times 0.002 = 2 \text{ lbs/ton}$ $\text{NH}_4\text{-N} = 2,000 \text{ ppm} \times 0.002 = 4 \text{ lbs/ton}$ $\text{TKN} = 27,000 \text{ ppm} \times 0.002 = 54 \text{ lbs/ton}$ $\text{Org-N} = 54 - (2 + 4) = 48 \text{ lbs/ton}$</p> <p>b) Calculating PAN: $\text{PAN} = 2 + 0.75 (4 \text{ lbs/ton}) + 0.3 (48 \text{ lbs/ton}) = 2 + 3 + 14.4 = 19.4 \text{ lbs/ton}$</p> <p>c) Dividing the adjusted fertilizer N rate (132 lbs N/dry ton) by the PAN/dry ton biosolid (19.4 lbs N/dry ton) to obtain the agronomic N rate (6.8 dry tons/acre).</p>
3	<p>Calculate the P-based agronomic rate using your state's P Site Index.</p>
4	<p>Calculate the lime-based agronomic rate:</p> <p>The coarse-textured Kempsville soil requires 0.75 tons limestone/acre to raise the pH to 6.5 (Donohue and Heckendorn, 1994). Use Equation 2 to determine the rate of lime-stabilized biosolids needed to provide 0.75 tons CCE/acre: Lime-based biosolids rate = tons of CCE required/acre ÷ biosolid's CCE/100 (0.75 tons CCE/acre) ÷ 40%/100 = 1.88 dry tons/acre.</p>
5	<p>Compare the rates calculated in the steps above:</p> <p>The N- and lime-based agronomic rates for the example above are 6.8 and 1.9 dry tons/acre, respectively. Dividing each of these rates by the fraction of solids in the biosolids (0.176) gives the wet weights of biosolids that must be applied to meet N- (39 wet tons/acre) and lime-based (11 wet tons/acre) application rates.</p> <p>No P (and, thus, no biosolids) would be recommended to meet plant P needs; however, a tool such as the P Index can be employed to calculate at what rate biosolids can be applied in an environmentally sound manner. Finally, the capability of equipment to spread very low rates and the economics of applying low rates may prevent biosolids from being applied at all.</p>

Land application methods

Introduction

The most appropriate application method for agricultural land depends on the physical characteristics of the biosolids and the soil, as well as the types of crops grown. Biosolids are generally land- applied using one of the following methods:

- sprayed or spread on the soil surface and left on the surface for pastures, range, and forest land; or.
- incorporated into the soil after being surface- applied or injected directly below the surface for producing row crops or other vegetation.

Both liquid and dewatered (or “cake”) biosolids may be applied to land with or without subsequent soil incorporation.

Applying liquid biosolids

Liquid biosolids can be applied by surface spreading or subsurface injection. Surface methods include spreading by tractor- drawn tank wagons, special applicator vehicles equipped with flotation tires, or irrigation systems. Surface application with incorporation is normally limited to soils with less than a 7% slope. Biosolids are commonly incorporated by plowing or disking after the liquid has been applied to the soil surface and allowed to partially dry, unless minimum or no-till systems are being used.

Spray irrigation systems generally should not be used to apply biosolids to forage or row crops during the growing season, although a light application to the stubble of a forage crop following a harvest is acceptable. The adherence of biosolids to plant vegetation can have a detrimental effect on crop yields by reducing photosynthesis and provides a more direct pathway for pollutant consumption by grazing animals. In addition, spray irrigation increases the potential for odor problems and reduces the aesthetics at the application site.

Liquid biosolids can also be injected below the soil surface using tractor- drawn tank wagons with injection shanks and tank trucks fitted with flotation tires and injection shanks. Both types of equipment minimize odor problems and reduce ammonia volatilization by immediate mixing of soil and biosolids. Injection can be used either before planting or after harvesting crops, but it is likely to be unacceptable for forages and sod production. Some injection shanks can damage the sod or forage stand and leave deep injection furrows in the field.

Subsurface injection will minimize runoff from all soils and can be used on slopes up to 15%. Injection should be made perpendicular to slopes to avoid having liquid biosolids run downhill along injection slits and pond at the

bottom of the slopes. As with surface application, drier soil will be able to absorb more liquid, thereby minimizing downslope movement.

Applying dewatered biosolids

Dewatered biosolids can be applied to cropland by equipment similar to that used for applying limestone, animal manures or commercial fertilizer. Typically, dewatered biosolids will be surface-applied and incorporated by plowing or another form of tillage. Incorporation is not used when applying dewatered biosolids to forages. Biosolids application methods such as incorporation and injection can be used to meet Part 503 vector attraction reduction requirements.

Timing of biosolids application

The timing of biosolids application must be scheduled around the tillage, planting, and harvesting operations and will be influenced by crop, climate, and soil properties. Traffic on wet soils during or immediately following heavy rainfalls may cause compaction and leave ruts in the soil, making crop production difficult and reducing crop yields. Muddy soils also make vehicle operation difficult and can create public nuisances by carrying mud out of the field and onto roadways.

Applications should also be made when crops will soon be able to utilize the N contained in the biosolids. Failure to do so could result in potential nitrate contamination of groundwater due to leaching of this water-soluble form of nitrogen. It is advisable that biosolids applied to land between autumn and spring have a vegetative cover (i.e., permanent pasture, winter cover crop, winter annual grain crop) to reduce erosion of sediment-bound biosolids, runoff of N, P, and pathogens, and leaching of nitrate.

Split applications may be required for rates of liquid biosolids (depending on the solids content) in excess of 2-3 dry tons/acre. Split application involves more than one application, each at a relatively low rate, to attain a higher total rate when the soil cannot assimilate the volume of the higher rate at one time.

Biosolids storage

In-field storage of biosolids at or near the application site is often needed. Storage facilities are required to hold biosolids during periods of inclement weather, equipment breakdown, frozen or snow-covered ground, or when land is unavailable due to growth of a crop. Liquid biosolids can be stored in digesters, tanks, lagoons, or drying beds; and dewatered biosolids can be stockpiled. Recommended guidelines for such storage have been specified by the U.S. EPA (2000).

Disadvantages of land application

Large land areas may be needed for agricultural use of biosolids because application rates are relatively low. Transportation and application scheduling

that is compatible with agricultural planting, harvesting, and possible adverse weather conditions require careful management.

Biosolids are typically delivered to the application site by tractor trailers containing approximately 20 tons. At a solids content of 15-25%, this is approximately 3-5 dry tons per trailer, or about the amount of biosolids that is normally spread onto one acre of land for crops such as corn, soybean or wheat. Therefore, there will be considerable truck volume over the course of several weeks for large sites of several hundred acres. Increased traffic on local roads, odors, and dust are potential impacts on the local community that should be addressed by notifying neighbors in public informational meetings or public hearings. Working out delivery schedules that are least likely to be disruptive will minimize the problems caused by biosolids transportation.

Biosolids, even when properly treated, will have odors. Under unfavorable weather conditions, the odors may be objectionable, even to rural communities accustomed to the use of animal manure. Odors may be reduced by stabilization process, application method, storage type, climatological conditions, and site selection, as described below.

- Stabilization reduces the biological activity and odor of biosolids. The products of aerobic digestion, heat treatment, and composting tend to result in the least objectionable odors. Anaerobic digestion has the potential to cause more odor than other treatment methods if not performed properly. Likewise, lime-stabilized biosolids, the most commonly used material in the state, may generate odors if not properly stabilized and managed.
- Application method affects the odor potential at the site. Immediate soil incorporation or direct soil injection will reduce the potential for odor problems.
- Biosolids storage can occur at the treatment plant, the site of application, or a temporary facility. Storage at the treatment plant (if isolated from the public) is the preferred method. Off-site storage requires proper site selection and management to minimize the potential for odor problems.
- Weather conditions (i.e., temperature, relative humidity, wind) will affect odor severity when biosolids are surface-applied. Spreading in the morning when air is warming and rising will help dilute the odor in the immediate vicinity.
- The selection of the application site is important to the success of the operation. Ideally, the site should be located away from residential areas.

Objectionable odors will sometimes be present despite adequate stabilization processes and favorable weather conditions. Complaints can be expected if

adjacent property owners are subjected to persistent odors. A well-managed system with the proper equipment and stabilized biosolids will substantially reduce the potential for unacceptable odors.

References cited

- Chaney, R.L. 1994. Trace metal movement: Soil-plant systems and bioavailability. p. 27-31. *In* C.E. Clapp, W.E. Larson, and R.H. Dowdy (eds.) Sewage sludge: Land utilization and the environment. Soil Sci. Soc. Amer. Miscellaneous Publication. Madison, WI.
- Donohue, S.J. and S.E. Heckendorn. 1994. Soil test recommendations for Virginia. Virginia Cooperative Extension Publication 834.
- Gilmour, J.T., C.G. Cogger, L.W. Jacobs, S.A. Wilson, G.K. Evanylo, and D.M Sullivan. 2000. Estimating plant-available nitrogen in biosolids. Project 97-REM-3. Water Environment Research Foundation. Alexandria, VA.
- Gilmour, J.T., C.G. Cogger, L.W. Jacobs, G.K. Evanylo, and D.M Sullivan. 2003. Decomposition and plant-available nitrogen in biosolids: Laboratory studies, field studies, and computer simulation. *J. Environ. Qual.* 32:1498-1507.
- National Research Council. 2002. Biosolids applied to land: Advancing standards and practices. The National Academies Press. Washington, DC.
- Shimp, G., K. Hunt, S. McMillian, and G. Hunter. 1994. Pretreatment raises biosolids quality. *Environ. Protection* 5(6).
- Simpson, T.W., S.J. Donohue, G.W. Hawkins, M.M. Monnett, and J.C. Baker. 1993. The development and implementation of the Virginia Agronomic Land Use Evaluation System (VALUES). Department of Crop and Soil Environmental Sciences, Virginia Tech, Blacksburg, VA.
- Stehouwer, R.C., A.M. Wolf, and W.T. Doty. 2000. Chemical monitoring of sewage sludge in Pennsylvania: Variability and application uncertainty. *J. Environ. Qual.* 29:1686-1695.
- Sukkariyah, B., K. Haering, and G. Evanylo. 2005. Land application of biosolids to provide plant nutrients, enhance soil properties, and prevent water quality impairment. Mid-Atlantic Regional Water Quality #5-03. Available on-line at:
http://www.agnr.umd.edu/users/waterqual/Publications/html_pubs/biosolids_wq_resource_directory.htm.
- U. S. EPA. 1984. Use and disposal of municipal wastewater sludge. EPA/625/10-84/003. U.S. Environmental Protection Agency, Washington, DC.

U.S. EPA. 1990. National sewage sludge survey: Availability of information and data, and anticipated impacts on proposed regulations. Fed. Reg. 55(218).

U.S. EPA. 1992a. Technical support document for land application of sewage sludge, Vol. I. EPA/822/R-93/900/9. U.S. Environmental Protection Agency. Washington, D.C.

U.S. EPA. 1992b. Technical support document for land application of sewage sludge, Vol. I. EPA/822/R-93/001A. U.S. Environmental Protection Agency. Washington, D.C.

U.S. EPA. 1995. Process Design Manual: Land Application of Sewage Sludge and Domestic Septage, Office of Research and Development. EPA/625/R-95/001. Washington, D.C.

U.S. EPA. 2000. Guide to field storage of biosolids. EPA/832-B-00-007. U.S. Environmental Protection Agency, Office of Wastewater Management. Washington, D.C.

Virginia Department of Health. 1997. Biosolids Use Regulations. 12 VAC 5-585-10 et seq. 32.1-164.5 of the Code of Virginia.
